

CADDY®

Mechanical Hangers and Supports for Plumbing, HVAC and Fire Protection



ERICO®

CADDY® Mechanical Hangers and Supports for Plumbing, HVAC and Fire Protection



DESIGNS

All dimensions are $\pm 5\%$ and product design and specifications are subject to change without notice.

DESIGN AND MANUFACTURING

Supports and hangers may be manufactured in conformance with one or more of the following:

Manufacturers Standardization Society MSS-SP-58

Federal Specification WW-H-171

Factory Mutual Research Corporation

Underwriters Laboratories, Inc.

National Fire Protection Association NFPA®-13 , NFPA 24

ANSI Code for Pressure Piping

TERMS AND CONDITIONS OF SALE

For ordering, terms and conditions of sale, please consult our current price guide.

WARNING

ERICO products shall be installed and used only as indicated in ERICO's product instruction sheets and training materials. Instruction sheets are available at www.erico.com and from your ERICO customer service representative. Improper installation, misuse, misapplication or other failure to completely follow ERICO's instructions and warnings may cause product malfunction, property damage, serious bodily injury and death.

WARRANTY

ERICO products are warranted to be free from defects in material and workmanship at the time of shipment. NO OTHER WARRANTY, WHETHER EXPRESS OR IMPLIED (INCLUDING ANY WARRANTY OF MERCHANTABILITY OR FITNESS FOR A PARTICULAR PURPOSE), SHALL EXIST IN CONNECTION WITH THE SALE OR USE OF ANY ERICO PRODUCTS. Claims for errors, shortages, defects or nonconformities ascertainable upon inspection must be made in writing within 5 days after Buyer's receipt of products. All other claims must be made in writing to ERICO within 6 months from the date of shipment or transport. Products claimed to be nonconforming or defective must, upon ERICO's prior written approval in accordance with its standard terms and procedures governing returns, promptly be returned to ERICO for inspection. Claims not made as provided above and within the applicable time period will be barred. ERICO shall in no event be responsible if the products have not been stored or used in accordance with its specifications and recommended procedures. ERICO will, at its option, either repair or replace nonconforming or defective products for which it is responsible or return the purchase price to the Buyer. THE FOREGOING STATES BUYER'S EXCLUSIVE REMEDY FOR ANY BREACH OF ERICO WARRANTY AND FOR ANY CLAIM, WHETHER SOUNDING IN CONTRACT, TORT OR NEGLIGENCE, FOR LOSS OR INJURY CAUSED BY THE SALE OR USE OF ANY PRODUCT.

LIMITATION OF LIABILITY

ERICO excludes all liability except such liability that is directly attributable to the willful or gross negligence of ERICO's employees. Should ERICO be held liable its liability shall in no event exceed the total purchase price under the contract. ERICO SHALL IN NO EVENT BE RESPONSIBLE FOR ANY LOSS OF BUSINESS OR PROFITS, DOWNTIME OR DELAY, LABOR, REPAIR OR MATERIAL COSTS OR ANY SIMILAR OR DISSIMILAR CONSEQUENTIAL LOSS OR DAMAGE INCURRED BY BUYER.

ANSI is a registered trademark of American National Standards Institute

ASTM is a registered trademark of ASTM International

UL is a registered trademark of Underwriters Laboratories, Inc.

ASME is a registered trademark of American Society of Mechanical Engineers

NFPA is a registered trademark of National Fire Protection Association



TABLE OF CONTENTS

Product Picture Reference	Pages I-XXV
1 Clevis Hangers	Page 3
2 Split Ring Hangers	Page 13
3 Loop Hangers	Page 19
4 Riser Clamps	Page 31
5 Pipe Fixings	Page 43
6 Universal Support System - CADDY® SPEED LINK	Page 61
7 Pipe and Equipment Supports - CADDY® PYRAMID	Page 65
8 Perforated Pipe Straps	Page 69
9 Strut Pipe Clamps	Page 73
10 CPVC Pipe Fixings	Page 85
11 Beam Clamps	Page 89
12 Structural Attachments	Page 115
13 Supports, Guides & Rollers	Page 135
14 Shields & Saddles	Page 155
15 Strut, Fittings & Accessories	Page 167
16 Stainless Steel Products	Page 209
17 Rods, Plates & Hardware	Page 217
18 Slotted Angle	Page 239
19 Sway Bracing	Page 243
20 Technical Information	Page 249





CLEVIS HANGERS

CHAPTER 1



Page 4

401



Page 5

CADDY® SLOT LOCK



Page 6

410



Page 7

402



Page 8

420



Page 9

401RO



Page 10

403



Page 11

405

SPLIT RING HANGERS

CHAPTER 2



Page 14

CADDY® SUPERFIX 454



Page 15

BH



Page 15

111



Page 16

455



Page 17

456





NEW

NEW



Page 20

100



Page 20

LHSR6



Page 21

115



Page 22

101



Page 23

100FL



Page 24

102



Page 25

102A



Page 26

103



Page 27

104



Page 27

VTR



Page 28

418



Page 29

418FL

NEW



Page 32

CADDY® EZ RISER



Page 33

510RO



Page 34

511



Page 35

520



Page 36

450



Page 37

451



Page 38

452



Page 39

453



Page 40

700



Page 41

705



Page 42

517



Page 42

516





Page 45

007



Page 45

STR



Page 46

008



Page 47

STR2



Page 47

470



Page 48

008CP



Page 48

008CU

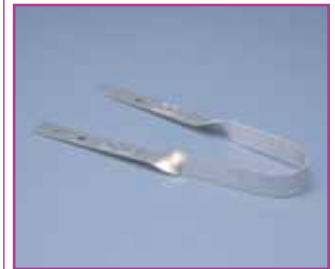

Page 49

U-Hanger



Page 49

DWV



Page 50

WH



Page 51

TPC



Page 51

CADDY® SUPERKLIP



Page 52

SMS8



Page 52

SGB



Page 52

TSGB



Page 53

150M



			
Page 54	Page 54	Page 55	Page 56
M-Series	MCP-Series	M-Series	MCP-Series
			
Page 57	Page 58	Page 59	Page 59
CD-Series	CDCP-Series	801	800
			
Page 60	Page 60		
802	EPS		



CADDY® SPEED LINK



NEW

Page 62

CADDY® SPEED LINK



NEW

Page 63

CADDY® SPEED LINK LD

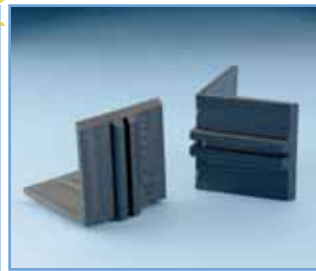

Page 64

SLADCP



Page 64

SLADS



Page 64

SLWC



Page 64

SLWPT



Page 64

SLEB

PIPE AND EQUIPMENT SUPPORTS

CHAPTER 7

CADDY® PYRAMID



NEW

Page 66

CADDY® PYRAMID 25



NEW

Page 67

CADDY® PYRAMID 50



NEW

Page 68

CADDY® PYRAMID 150
CADDY® PYRAMID 300
CADDY® PYRAMID 600



 <p>NEW</p>			
<p>Page 74</p> <p>RIGD</p>	<p>Page 75</p> <p>OD</p>	<p>Page 76</p> <p>PCC</p>	<p>Page 77</p> <p>TCC</p>
		 <p>NEW</p>	 <p>NEW</p>
<p>Page 78</p> <p>COPC</p>	<p>Page 78</p> <p>EMTC</p>	<p>Page 79</p> <p>TSM</p>	<p>Page 79</p> <p>TSMI</p>
 <p>NEW</p>	 <p>NEW</p>		
<p>Page 80</p> <p>SCH</p>	<p>Page 81</p> <p>SK</p>	<p>Page 82</p> <p>STR</p>	<p>Page 82</p> <p>STR2</p>
			
<p>Page 83</p> <p>UNIV</p>	<p>Page 83</p> <p>VS-20</p>		



NEW



Page 86

107



Page 86

108



Page 87

109



Page 87

50



			
Page 91	Page 92	Page 93	Page 94
280	300	310	255
			
Page 95	Page 96	Page 97	Page 98
255L	BC26	200	200RS
			
Page 99	Page 100	Page 101	Page 102
547/548	PH	PHSW	BC13
			
Page 103	Page 104		
BC14	BC10		





Page 105

BC15



Page 105

BC09



Page 106

315



Page 107

PAR



Page 107

ET



Page 108

RA



Page 109

300C



Page 110

35RS



Page 110

34SL



Page 111

255C

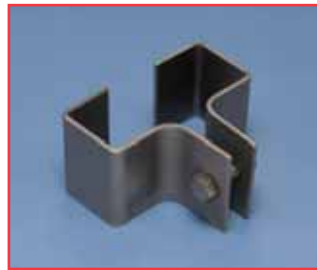

Page 111

356



Page 112

360



Page 113









361

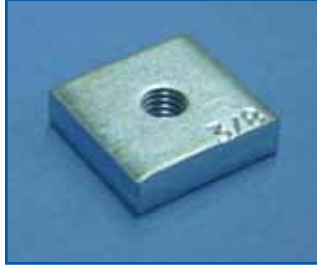

Page 114

363



			
Page 117	Page 117	Page 118	Page 119
365M	365	355	355N
			
Page 120	Page 121	Page 122	Page 123
370A	37	38	325
			
Page 124	Page 125	Page 126	Page 127
326	327	328	319



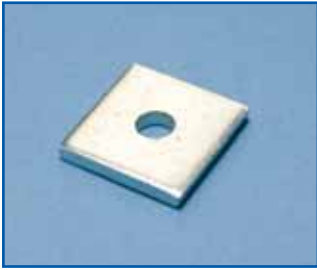

Page 127

340



Page 128

320L / 320W



Page 129

348

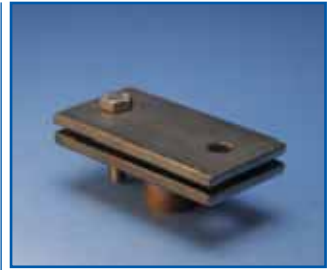

Page 130

350



Page 130

351



Page 131

352



Page 132

353



Page 133

4TI/6TI



Page 133

AF



Page 134

VF



Page 134

VAFT





Page 136

605



Page 137

610



Page 138

615



Page 139

617



Page 140

619

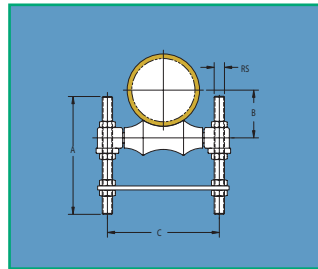

Page 141

620



Page 142-143

ROL12



Page 142-143

ROL13



Page 144

ROL14



Page 145

ROL15

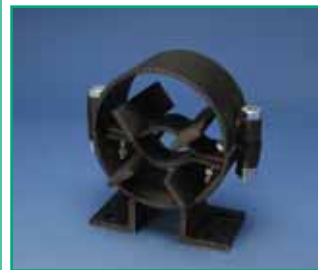

Page 146-147

650



Page 148-149

651



Page 150

721



Page 151

722



Page 152

723



Page 153

724



STRUT, FITTINGS & ACCESSORIES CHAPTER 15



Page 173

A12



Page 174

A14



Page 174

B12



Page 175

C12



Page 176

C14



Page 176

D12



Page 177

E12



Page 177

CONC



Page 178

CADDY® SLICK



Page 179

STS



Page 180

NUT



Page 180

NUTC



Page 181

SPRA



Page 181

SPRC



Page 182

SPRD



Page 182

SPRM



STRUT, FITTINGS & ACCESSORIES CHAPTER 15

NEW!



Page 183

TSNT



Page 184

SQNT



Page 184

VS



Page 185

STCB



Page 186

BC16



Page 186

BC17



Page 187

BR22



Page 187

Strut Cover

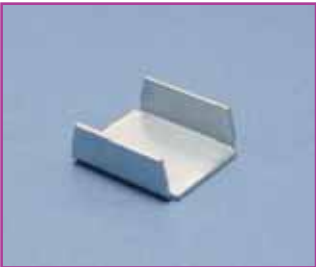

Page 188

ENDC



Page 188

F09



Page 189

F10-F12



Page 189

F13-F18



Page 190

F20



Page 190

F22



CADDY

STRUT, FITTINGS & ACCESSORIES CHAPTER 15



Page 191

F23



Page 191

F25



Page 192

F36



Page 192

F37



Page 193

L10



Page 193

L11



Page 194

L12



Page 194

L15



Page 195

L16-L17



Page 195

L18



Page 196

L19-L20



Page 196

L22



Page 197

L23



Page 197

L24

STRUT, FITTINGS & ACCESSORIES CHAPTER 15

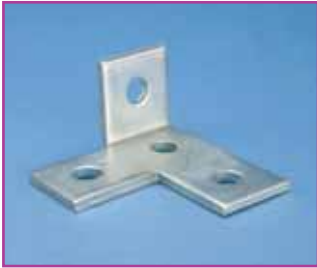

Page 198

L25



Page 198

L26



Page 199

L27



Page 199

L44



Page 200

L46



Page 200

L47



Page 201

P09



Page 201

P10



Page 202

P11



Page 202

P13



Page 203

ROL10



Page 203

ROL11



Page 204

U10A



Page 204

U24



STRUT, FITTINGS & ACCESSORIES CHAPTER 15



Page 205

W10



Page 205

W12



Page 206

W13



Page 206

W17



Page 207

W18



Page 207

W19



Page 208

W20



Page 208

W23



Page 210

105



Page 211

406



Page 212

305



Page 213

150



Page 214

OD



Page 215

RIGD



			
Page 220	Page 220	Page 221	Page 221
304B2	005	10	10H
			
Page 222	Page 222	Page 223	Page 224
11	12	50	51
			
Page 224	Page 225	Page 225	Page 226
25	25S	25R	41
			
Page 226	Page 227	Page 227	Page 227
42	43	100A	145





Page 228



Page 229



Page 229



Page 230

Hardware Anchors HMZ

345R

RAWL

26



Page 230

30



Page 231

31



Page 231

SWF



Page 232

35



Page 232

SWFF



Page 233

40



Page 233

SWM



Page 234

47



Page 234

SWMF



Page 235

HSCR



Page 235

85



Page 236

80





Page 244

TP220



Page 245

TP225



Page 245

TP225A



Page 246

TP230



Page 247

TP235



Page 247

TP240



Page 248

TP280

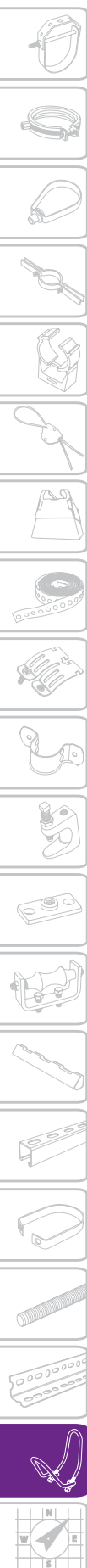



Page 4

401



Page 5

CADDY® SLOT LOCK



Page 6

410



Page 7

402



Page 8

420



Page 9

401RO



Page 10

403



Page 11

405





CLEVIS HANGER 401

Standard Duty

- Size Range: 1/2" through 24"
- Surface Finish: Electro-zinc plated
- Recommended for the suspension of stationary non-insulated pipe lines
- Standard electro-zinc plated finish is cleaner, provides superior corrosion protection
- Conforms with Federal Specification WW-H-171 (Type 1), Manufacturers Standardization Society (MSS) SP-58 and SP-69 (Type 1)



Part Number	Nominal Pipe Size	RS	A	B	Max. Rec. Load (lbs)
4010050EG	1/2"	3/8	2-1/8"	1-5/8"	610
4010075EG	3/4"	3/8	2-3/8"	1-3/4"	610
4010100EG	1"	3/8	2-3/4"	2-1/16"	610
4010125EG	1-1/4"	3/8	3-5/16"	2-3/8"	610
4010150EG	1-1/2"	3/8	3-15/16"	2-15/16"	610
4010200EG	2"	3/8	4-1/2"	3-1/4"	610
4010250EG	2-1/2"	1/2	5-1/4"	3-3/4"	1130
4010300EG	3"	1/2	6"	4-1/8"	1130
4010350EG	3-1/2"	1/2	6-1/2"	4-7/16"	1130
4010400EG	4"	5/8	7-3/4"	5-3/8"	1130
4010500EG	5"	5/8	9-3/4"	6-13/16"	1430
4010600EG	6"	3/4	11-3/4"	8-1/4"	1940
4010800EG	8"	3/4	14"	9-1/2"	2000
4011000EG	10"	7/8	16-1/2"	10-7/8"	3600
4011200EG	12"	7/8	18-5/8"	12"	3800
4011400EG	14"	1	21-3/4"	14-1/2"	4200
4011600EG	16"	1	24"	15-3/4"	4600
4011800EG	18"	1-1/8	26-3/4"	17-1/2"	4800
4012000EG	20"	1-1/4	30"	19-5/8"	4800
4012400EG	24"	1-1/4	34-1/8"	21-3/4"	4800

2-1/2" - 8"

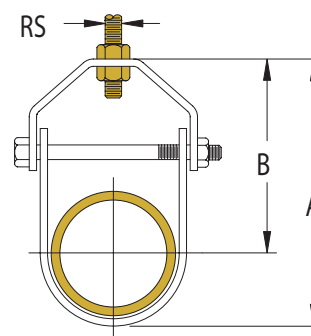



CADDY® SLOT LOCK



Standard Duty

- Size Range: 2" and 4"
- Surface Finish: Electro-zinc plated
- Slotted crossbeam design is easier to assemble than conventional nut and bolt style clevis hangers
- Eliminates the need to install additional parts to control deflection
- Recommended for the suspension of stationary non-insulated pipe lines
- Standard electro-zinc plated finish is cleaner, provides superior corrosion protection
- Conforms with Federal Specification WW-H-171 (Type 1), Manufacturers Standardization Society (MSS) SP-58 and SP-69 (Type 1)



Patent Pending

Part Number	Nominal Pipe Size	RS	A	B	Max. Rec. Load (lbs)
4270200EG	2"	3/8	4-11/16"	3-3/8"	610
4270400EG	4"	5/8	7-3/4"	5-3/8"	1130

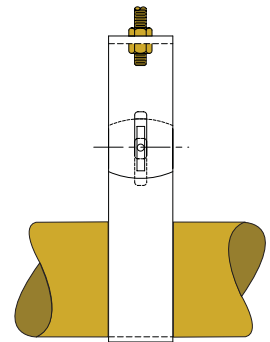
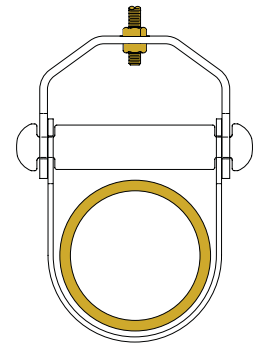

Features

- UL® Listed and FM approved
- Each assembly comes individually bagged, ready to assemble
- Patent-pending slotted crossbeam design is easier and faster to assemble than conventional nut and bolt style hangers
- Notches in the crossbeam capture the top and bottom legs under load, minimizing deflection
- Meets FM deflection requirements without the need to install additional parts
- Has successfully passed the rigorous vibration testing requirements for both UL and FM



"The CADDY® SLOT LOCK Hanger is UL Listed under UL 203 for fire protection applications"



CLEVIS HANGER 410

Light Duty

- Size Range: 1/2" through 8"
- Surface Finish: Electro-zinc plated
- Recommended for the suspension of light stationary non-insulated pipe or conduit lines
- Conforms with Federal Specification WW-H-171 (Type 1), Manufacturers Standardization Society (MSS) SP-58 and SP-69 (Type 1)
- Standard electro-zinc plated finish is cleaner, provides superior corrosion protection



Part Number	Nominal Pipe Size	RS	A	B	Max. Rec. Load (lbs)
4100050EG	1/2 "	3/8	2-1/8 "	1-5/8 "	150
4100075EG	3/4 "	3/8	2-3/8 "	1-3/4 "	150
4100100EG	1 "	3/8	2-3/4 "	2-1/16 "	250
4100125EG	1-1/4 "	3/8	3-5/16 "	2-3/8 "	250
4100150EG	1-1/2 "	3/8	4 "	2-15/16 "	250
4100200EG	2 "	3/8	4-1/2 "	3-3/16 "	250
4100250EG	2-1/2 "	1/2	5-1/4 "	3-11/16 "	350
4100300EG	3 "	1/2	6 "	4-3/16 "	350
4100350EG	3-1/2 "	1/2	6-1/2 "	4-3/8 "	400
4100400EG	4 "	5/8	7-3/4 "	5-3/8 "	500
4100500EG	5 "	5/8	9-3/4 "	6-13/16 "	600
4100600EG	6 "	3/4	11-3/4 "	8-1/4 "	800
4100800EG	8 "	3/4	14 "	9-1/2 "	1200

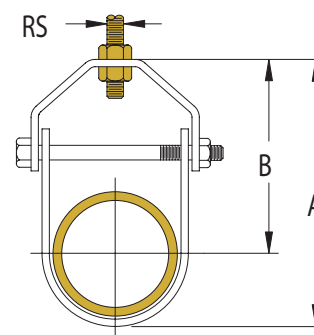



CLEVIS HANGER 402

Light Duty for Copper Tubing

- Size Range: 1/2" through 8"
- Surface Finish: Copper-colored coating (for identification purposes only)
- Recommended for the suspension of stationary non-insulated copper tubing lines
- Conforms with Federal Specification WW-H-171 (Type 12), Manufacturers Standardization Society (MSS) SP-58 and SP-69 (Type 1)



Part Number	Nominal Pipe Size	RS	A	B	Max. Rec. Load (lbs)
4020050CP	1/2"	3/8	2-1/16"	1-11/16"	215
4020075CP	3/4"	3/8	2-5/16"	1-13/16"	215
4020100CP	1"	3/8	3"	2-3/8"	215
4020125CP	1-1/4"	3/8	2-3/4"	2"	215
4020150CP	1-1/2"	3/8	3-5/16"	2-7/16"	215
4020200CP	2"	3/8	4-1/16"	2-7/8"	215
4020250CP	2-1/2"	1/2	4-13/16"	3-5/16"	250
4020300CP	3"	1/2	5-1/2"	3-3/4"	300
4020350CP	3-1/2"	1/2	6-1/8"	4-1/8"	360
4020400CP	4"	1/2	6-3/4"	4-1/2"	440
4020500CP	5"	1/2	9-1/8"	6-3/8"	600
4020600CP	6"	5/8	11-1/16"	7-7/8"	760
4020800CP	8"	3/4	14-7/8"	10-9/16"	1160

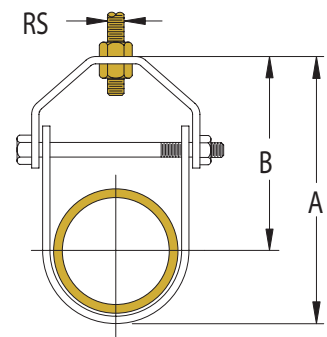



CLEVIS HANGER 420

Standard Duty Epoxy Coated

- Size Range: 1/2" through 8"
- Surface Finish: Epoxy Coated
- Recommended for the suspension of stationary non-insulated pipe lines where it is undesirable to have the steel of the hanger in direct contact with the pipe
- Conforms with Federal Specification WW-H-171 (Type 1), Manufacturers Standardization Society (MSS) SP-58 and SP-69 (Type 1)



Part Number	Nominal Pipe Size	RS	A	B	Max. Rec. Load (lbs)
4200050EP	1/2"	3/8	2-1/8"	1-5/8"	610
4200075EP	3/4"	3/8	2-3/8"	1-3/4"	610
4200100EP	1"	3/8	2-3/4"	2-1/16"	610
4200125EP	1-1/4"	3/8	3-5/16"	2-3/8"	610
4200150EP	1-1/2"	3/8	3-15/16"	2-15/16"	610
4200200EP	2"	3/8	4-1/2"	3-1/4"	610
4200250EP	2-1/2"	1/2	5-1/4"	3-3/4"	1130
4200300EP	3"	1/2	6"	4-1/8"	1130
4200400EP	4"	1/2	7-3/4"	5-3/8"	1130
4200500EP	5"	1/2	9-3/4"	6-13/16"	1430
4200600EP	6"	1/2	11-3/4"	8-1/4"	1940
4200800EP	8"	1/2	14"	9-1/2"	2000

2-1/2" - 8"

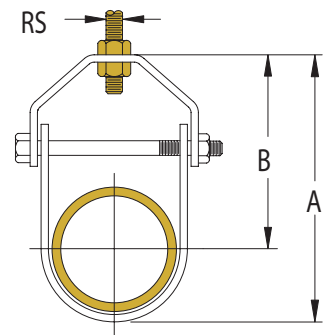



CLEVIS HANGER 401RO

Standard Duty

- Size Range: 1/2" through 24"
- Surface Finish: Red-oxide primer coating
- Recommended for the suspension of stationary non-insulated pipe lines
- Conforms with Federal Specification WW-H-171 (Type 1), Manufacturers Standardization Society (MSS) SP-58 and SP-69 (Type 1)



Part Number	Nominal Pipe Size	RS	A	B	Max. Rec. Load (lbs)
4010050RO	1/2"	3/8	2-1/8"	1-5/8"	610
4010075RO	3/4"	3/8	2-3/8"	1-3/4"	610
4010100RO	1"	3/8	2-3/4"	2-1/16"	610
4010125RO	1-1/4"	3/8	3-5/16"	2-3/8"	610
4010150RO	1-1/2"	3/8	3-15/16"	2-15/16"	610
4010200RO	2"	3/8	4-1/2"	3-1/4"	610
4010250RO	2-1/2"	1/2	5-1/4"	3-3/4"	1130
4010300RO	3"	1/2	6"	4-1/8"	1130
4010350RO	3-1/2"	1/2	6-1/2"	4-7/16"	1130
4010400RO	4"	5/8	7-3/4"	5-3/8"	1130
4010500RO	5"	5/8	9-3/4"	6-13/16"	1430
4010600RO	6"	3/4	11-3/4"	8-1/4"	1940
4010800RO	8"	3/4	14"	9-1/2"	2000
4011000RO	10"	7/8	16-1/2"	10-7/8"	3600
4011200RO	12"	7/8	18-5/8"	12"	3800
4011400RO	14"	1	21-3/4"	14-1/2"	4200
4011600RO	16"	1	24"	15-3/4"	4600
4011800RO	18"	1-1/8	26-3/4"	17-1/2"	4800
4012000RO	20"	1-1/4	30"	19-5/8"	4800
4012400RO	24"	1-1/4	34-1/8"	21-3/4"	4800

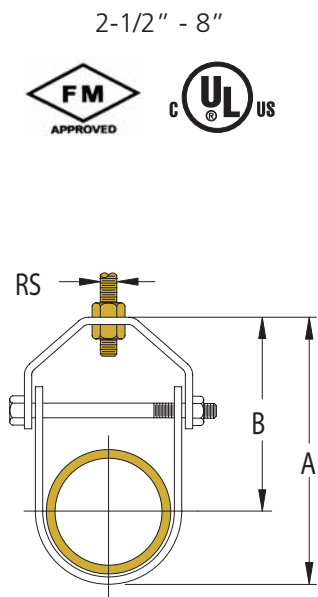



CLEVIS HANGER 403

Standard Duty with Insulation Shield

- Size Range: 1-1/2" through 22"
- Surface Finish: Electro-zinc plated
- Recommended for the suspension of stationary non-insulated pipe lines
- Conforms with Federal Specification WW-H-171 (Type 1), Manufacturers Standardization Society (MSS) SP-58 and SP-69 (Type 1)



Part Number	Nominal Pipe Size	RS	A	B	C	Max. Rec. Load (lbs)
4030150EG	1-1/2"	3/8	5"	3-13/16"	3"	610
4030200EG	2"	3/8	5-5/16"	3-15/16"	3"	610
4030250EG	2-1/2"	1/2	6-3/16"	4-7/16"	4"	1130
4030300EG	3"	1/2	6-3/4"	4-11/16"	4"	1130
4030350EG	3-1/2"	1/2	7-1/4"	4-15/16"	4"	1130
4030400EG	4"	5/8	7-1/4"	4-11/16"	6"	1130
4030450EG	4-1/2"	5/8	9-9/16"	6-7/8"	6"	1430
4030500EG	5"	5/8	10"	6-15/16"	6"	1430
4030600EG	6"	3/4	11-1/16"	7-7/16"	6"	1940
4030700EG	7"	3/4	12-15/16"	8-7/8"	6"	1940
4030800EG	8"	3/4	13-13/16"	9-5/16"	6"	2000
4030900EG	9"	7/8	14-3/8"	8-7/8"	6"	2000
4031000EG	10"	7/8	16-5/16"	10-5/16"	6"	3600
4031100EG	11"	7/8	18-3/8"	11-7/8"	8"	3600
4031200EG	12"	7/8	19-5/8"	12-5/8"	8"	3800
4031400EG	14"	1	20-1/2"	13"	8"	4200
4031500EG	15"	1	20-5/8"	12-3/8"	8"	4200
4031600EG	16"	1	22-1/2"	14"	8"	4600
4031700EG	17"	1-1/8	23-3/4"	14-3/4"	10"	4600
4031800EG	18"	1-1/8	25-13/16"	16-3/4"	10"	4800
4031900EG	19"	1-1/4	27-1/2"	17-3/4"	10"	4800
4032000EG	20"	1-1/4	29"	18-3/8"	10"	4800
4032100EG	21"	1-1/4	29-1/4"	18-1/4"	10"	4800
4032200EG	22"	1-1/4	30-1/4"	18-5/8"	10"	4800

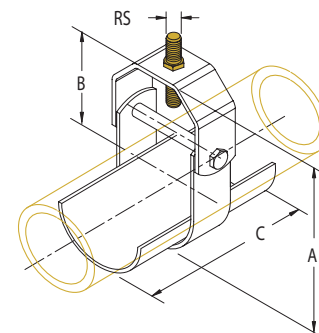

Flared edges on shield sizes thru 4 only





CLEVIS HANGER 405

Standard Duty AWWA Cast Iron Pipe

- Size Range: 3" through 24"
- Surface Finish: Black (Plain)
- Recommended for the suspension of stationary non-insulated cast iron pipe lines
- Conforms with Federal Specification WW-H-171 (Type 1), Manufacturers Standardization Society (MSS) SP-58 and SP-69 (Type 1)



Part Number	Nominal Pipe Size	RS	A	B	Max. Rec. Load (lbs)
4050300PL	3"	1/2	6-11/16"	4-1/2"	1130
4050400PL	4"	5/8	8-3/8"	5-11/16"	1430
4050600PL	6"	3/4	10-5/8"	7"	1940
4050800PL	8"	7/8	13-1/4"	8-3/8"	2000
4051000PL	10"	7/8	15-7/8"	10-1/8"	3600
4051200PL	12"	7/8	17-3/8"	10-1/8"	3800
4051400PL	14"	1	21-5/8"	13-1/2"	4200
4051600PL	16"	1	23-3/4"	14-7/8"	4600
4051800PL	18"	1-1/8	26-3/8"	16-1/2"	4800
4052000PL	20"	1-1/4	29-5/8"	18-11/16"	4800
4052400PL	24"	1-1/4	34-7/8"	21-13/16"	4800

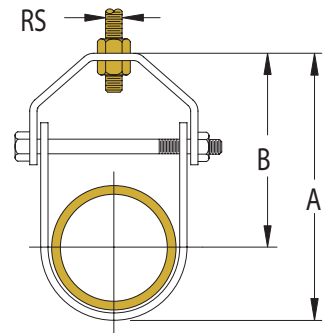



NEW Products



CADDY® SUPERFIX 454 SPLIT RING HANGER

- Recommended for the suspension of stationary non-insulated pipe lines
- EPDM rubber insulation for sound reduction compliant with DIN 4109
- Comes with a welded 3/8" cap nut, allowing easy attachment to threaded rod

See page 14



Bell Hanger

- Mounting screw is recessed and has a pierce-point to penetrate metal studs
- Provides 13/16" standoff

See page 15





NEW!

NEW!



Page 14

CADDY® SUPERFIX 454



Page 15

BH



Page 15

111



Page 16

455



Page 17

456



CADDY® SUPERFIX 454 SPLIT RING HANGER

Light Duty

- Size Range: 1/4" through 4"
- Surface Finish: Electro-zinc plated
- Recommended for the suspension of stationary non-insulated pipe lines
- EPDM rubber insulation for sound reduction compliant with DIN 4109
- Temperature range from -58°F to 230°F
- Conforms with Manufacturers Standardization Society (MSS) SP-58 and SP-69 (Type 12)



Part Number	Nominal Pipe Size		A	B	C	Max. Rec. Load (lbs)
	IP	CT				
454001	1/4"	3/8"	15/32" - 9/16"	29/32"	M6x25	180
454002	3/8"	1/2"	19/32" - 3/4"	29/32"	M6x25	180
454003	-	5/8"	19/32" - 3/4"	29/32"	M6x25	180
454004	1/2"	3/4"	13/16" - 29/32"	29/32"	M6x25	180
454005	3/4"	1"	1-1/32" - 1-3/32"	29/32"	M6x25	180
454006	1"	1-1/4"	1-1/4" - 1-3/8"	29/32"	M6x30	180
454007	1-1/4"	1-1/2"	1-9/16" - 1-11/16"	29/32"	M6x30	180
454008	1-1/2"	-	1-3/4" - 1-15/16"	29/32"	M6x30	180
454009	-	2"	2-1/8" - 2-9/32"	15/16"	M6x30	180
454010	2"	-	2-1/4" - 2-13/32"	29/32"	M6x30	180
454011	-	2-1/2"	2-1/2" - 2-5/8"	29/32"	M6x30	300
454012	2-1/2"	-	2-3/4" - 2-7/8"	15/16"	M6x30	300
454013	-	3"	2-29/32" - 3-5/32"	15/16"	M6x35	300
454014	3"	-	3-9/32" - 3-9/16"	15/16"	M6x35	300
454015	-	3-1/2"	3-5/8" - 3-15/16"	29/32"	M6x35	300
454016	3-1/2"	4"	3-31/32" - 4-3/16"	1-1/8"	M6x35	300
454017	4"	-	4-1/4" - 4-1/2"	1-1/8"	M6x40	300

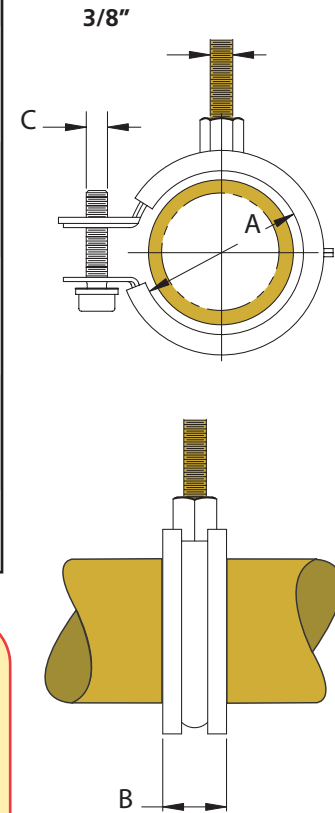

Features

- Comes with a welded 3/8" cap nut, allowing easy attachment to threaded rod
- Equipped with an EPDM rubber sleeve that serves to minimize noise
- Has a fire rating DIN EN 13501-1:E



BELL HANGER BH

Light Duty

- Size Range: 1/2" through 1"
- Surface Finish: Copper plated
- Provides 13/16" standoff
- Mounting screw is recessed and has a pierce-point to penetrate metal studs



Part Number	Nominal Pipe Size
BH0050CP	1/2"
BH0075CP	3/4"
BH0100CP	1"

SPLIT RING HANGER 111

Malleable Iron Swivel Split Ring

- Size Range: 3/4" through 6"
- Surface Finish: Black
- Recommended for the suspension of stationary non-insulated pipe lines
- Conforms with Federal Specification WW-H-171 (Type 6), Manufacturers Standardization Society (MSS) SP-58 and SP-69 (Type 6)
- Offset hinge design allows for installation or removal of pipe after the hanger is installed
- Swivel insert allows for vertical adjustment during installation
- Locking clip allows for arm to be opened and closed without the use of tools
- Max. temperature service 450°F
- Locking clip and rivet are carbon steel



Part Number	Nominal Pipe Size	RS	A	B	Max. Rec. Load (lbs)
1110075PL	3/4"	3/8"	3"	1-5/16"	300
1110100PL	1"	3/8"	3-1/4"	1-5/16"	300
1110125PL	1-1/4"	3/8"	3-1/2"	1-5/16"	300
1110150PL	1-1/2"	3/8"	3-7/8"	1-5/16"	300
1110200PL	2"	3/8"	4-1/2"	1-5/16"	300
1110250PL	2-1/2"	1/2"	6-3/8"	2-1/4"	500
1110300PL	3"	1/2"	7"	2-1/4"	500
1110350PL	3-1/2"	1/2"	7-7/8"	2-1/4"	500
1110400PL	4"	5/8"	9-1/8"	3-1/8"	900
1110500PL	5"	5/8"	10-3/4"	3-1/8"	900
1110600PL	6"	3/4"	12"	3-3/8"	1300

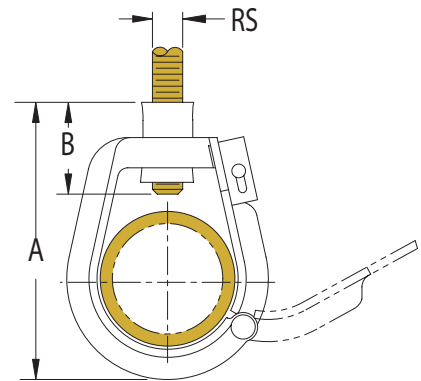



SPLIT RING HANGER 455

Malleable Iron Split Ring Stand-Off Hanger

- Size Range: 3/8" through 4"
- Surface Finish: Electro-zinc plated
- Recommended for the suspension of stationary non-insulated pipe lines
- Allows for piping runs close to ceiling or walls
- Conforms with Federal Specification WW-H-171 (Type 25), Manufacturers Standardization Society (MSS) SP-58 and SP-69 (Type 12)
- Bolt and rivet are carbon steel



Part Number	Nominal Pipe Size	RS	A	B	Max. Rec. Load (lbs)
Plain Finish					
4550037PL	3/8"	3/8"	1-5/16"	3/8"	180
4550050PL	1/2"	3/8"	1-1/2"	3/8"	180
4550075PL	3/4"	3/8"	1-3/4"	7/16"	180
4550100PL	1"	3/8"	2"	7/16"	180
4550125PL	1-1/4"	3/8"	2-3/8"	1/2"	180
4550150PL	1-1/2"	3/8"	2-5/8"	1/2"	180
4550200PL	2"	3/8"	3-1/8"	1/2"	180
4550250PL	2-1/2"	1/2"	3-3/4"	5/8"	300
4550300PL	3"	1/2"	4-3/8"	5/8"	300
4550400PL	4"	1/2"	5-3/8"	11/16"	300
Electro-zinc Plated Finish					
4550037EG	3/8"	3/8"	1-5/16"	3/8"	180
4550050EG	1/2"	3/8"	1-1/2"	3/8"	180
4550075EG	3/4"	3/8"	1-3/4"	7/16"	180
4550100EG	1"	3/8"	2"	7/16"	180
4550125EG	1-1/4"	3/8"	2-3/8"	1/2"	180
4550150EG	1-1/2"	3/8"	2-5/8"	1/2"	180
4550200EG	2"	3/8"	3-1/8"	1/2"	180
4550250EG	2-1/2"	1/2"	3-3/4"	5/8"	300
4550300EG	3"	1/2"	4-3/8"	5/8"	300
4550400EG	4"	1/2"	5-3/8"	11/16"	300

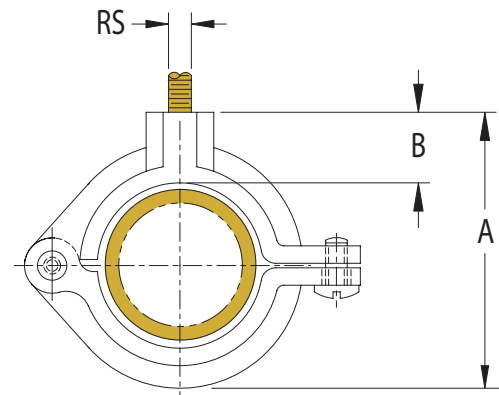

SPLIT RING HANGER 456

Malleable Iron Split Ring Stand-off Hanger for Copper Tubing

- Size Range: 3/8" through 3"
- Surface Finish: Copper-colored coating (for identification purposes only)
- Recommended for the suspension of stationary non-insulated copper tubing lines
- Allows for piping runs close to ceiling or walls
- Conforms with Federal Specification WW-H-171 (Type 25), Manufacturers Standardization Society (MSS) SP-58 and SP-69 (Type 12)
- Bolt and rivet are carbon steel



Part Number	Nominal Pipe Size	RS	A	B	Max. Rec. Load (lbs)
4560037CP	3/8"	3/8"	15/16"	5/16"	180
4560050CP	1/2"	3/8"	1-1/8"	3/8"	180
4560075CP	3/4"	3/8"	1-3/8"	3/8"	180
4560100CP	1"	3/8"	1-5/8"	3/8"	180
4560125CP	1-1/4"	3/8"	1-7/8"	3/8"	180
4560150CP	1-1/2"	3/8"	2-1/8"	3/8"	180
4560200CP	2"	3/8"	2-5/8"	3/8"	180
4560250CP	2-1/2"	1/2"	3-3/8"	5/8"	180
4560300CP	3"	1/2"	3-7/8"	5/8"	180

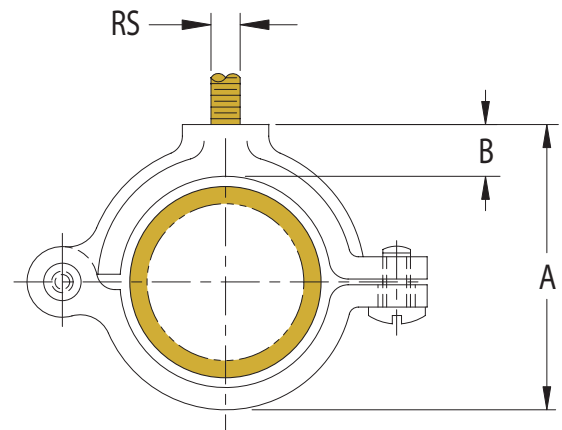

NEW Products



SWIVEL LOOP HANGER 100

- Recommended for the suspension of stationary non-insulated pipe lines
- Features a retained insert nut to ensure that the loop hanger and insert nut stay together

See page 20



LOOP HANGER SURGE RESTRAINT LHSR6

- Grips the loop hanger – not the nut – allowing fine tuning for height adjustment
- Installs without tools
- Restricts the upward surge movement of activated fire sprinkler systems

See page 20



 <p>NEW</p>	 <p>NEW</p>		
Page 20	Page 20	Page 21	Page 22
100	LHSR6	115	101
			
Page 23	Page 24	Page 25	Page 26
100FL	102	102A	103
			
Page 27	Page 27	Page 28	Page 29
104	VTR	418	418FL



SWIVEL LOOP HANGER 100

Heavy Duty Adjustable Band Hanger

- Size Range: 1/2" through 8"
- Surface Finish: Electro-zinc plated
- Recommended for the suspension of stationary non-insulated pipe lines
- Features a retained insert nut to ensure that the loop hanger and insert nut stay together
- Conforms with Federal Specification WW-H-171 (Type 10), Manufacturers Standardization Society (MSS) SP-58 and SP-69 (Type 10)



Part Number	Nominal Pipe Size	RS	A	B	Max. Rec. Load (lbs)
1000050EG	1/2"	3/8"	2-3/4"	1"	300
1000075EG	3/4"	3/8"	3-1/16"	1"	300
1000100EG	1"	3/8"	3-5/16"	1"	300
1000125EG	1-1/4"	3/8"	3-9/16"	1"	300
1000150EG	1-1/2"	3/8"	3-13/16"	1"	300
1000200EG	2"	3/8"	4-1/4"	1"	300
1000250EG	2-1/2"	1/2"	5-5/8"	1-1/4"	1000
1000300EG	3"	1/2"	6-9/16"	1-1/4"	1000
1000350EG	3-1/2"	1/2"	7"	1-1/4"	1000
1000400EG	4"	5/8"	7-3/4"	1-5/16"	1100
1000500EG	5"	5/8"	9-1/8"	1-5/16"	1100
1000600EG	6"	3/4"	10-5/8"	1-9/16"	1250
1000800EG	8"	7/8"	13-1/8"	1-5/8"	1250

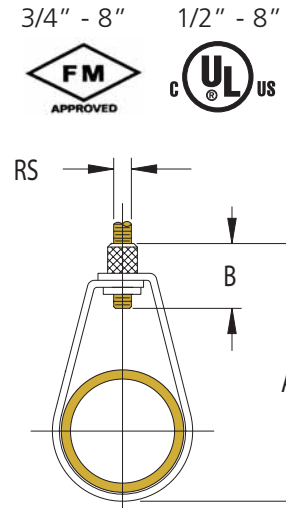

LOOP HANGER SURGE RESTRAINT LHSR6

Heavy Duty Adjustable Band Hanger

- Size Range: fits 1/2" through 2" model 100 loop hangers
- Surface Finish: CADDY® COAT Black
- Restricts the upward surge movement of activated fire sprinkler systems
- Meets NFPA® 13 requirements
- One size fits 1/2" thru 2" sizes of the model 100 loop hanger
- Grips the loop hanger – not the nut – allowing fine tuning for height adjustment
- Installs without tools



SWIVEL LOOP HANGER 115

Adjustable Band Hanger with NFPA Rod Sizes

- Size Range: 2-1/2" through 8"
- Surface Finish: Electro-zinc plated
- Recommended for the suspension of stationary non-insulated pipe lines
- Manufactured to use the minimum rod size permitted by NFPA for fire sprinkler piping
- Conforms with Federal Specification WW-H-171 (Type 10), Manufacturers Standardization Society (MSS) SP-58 and SP-69 (Type 10)



Part Number	Nominal Pipe Size	RS	A	B	Max. Rec. Load (lbs)
1150250EG	2-1/2"	3/8"	5-9/16"	1"	525
1150300EG	3"	3/8"	6-9/16"	1"	525
1150350EG	3-1/2"	3/8"	7-1/16"	1"	585
1150400EG	4"	3/8"	7-9/16"	1"	650
1150500EG	5"	1/2"	9-3/16"	1-1/4"	1000
1150600EG	6"	1/2"	11-5/16"	1-1/4"	1000
1150800EG	8"	1/2"	12-7/8"	1-1/4"	1000

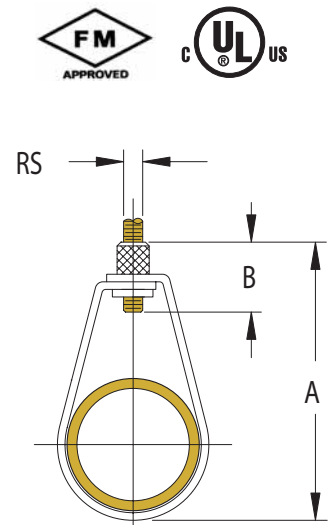

SWIVEL LOOP HANGER 101

Adjustable Band Hanger for Copper Tubing

- Size Range: 1/2" through 6"
- Surface Finish: Copper-colored coating (for identification purposes only)
- Recommended for the suspension of stationary non-insulated copper tubing lines
- Conforms with Federal Specification WW-H-171 (Type 10), Manufacturers Standardization Society (MSS) SP-58 and SP-69 (Type 10)



Part Number	Nominal Pipe Size	RS	A	B	Max. Rec. Load (lbs)
1010050CP	1/2"	3/8"	3-3/16"	1"	180
1010075CP	3/4"	3/8"	3-1/8"	1"	180
1010100CP	1"	3/8"	3-1/8"	1"	180
1010125CP	1-1/4"	3/8"	3-3/16"	1"	180
1010150CP	1-1/2"	3/8"	3-5/8"	1"	180
1010200CP	2"	3/8"	3-13/16"	1"	180
1010250CP	2-1/2"	3/8"	4-7/16"	1"	200
1010300CP	3"	1/2"	5-11/16"	1-1/4"	250
1010350CP	3-1/2"	1/2"	6-7/16"	1-1/4"	300
1010400CP	4"	1/2"	7-1/8"	1-1/4"	360
1010500CP	5"	5/8"	9-1/4"	1-5/16"	480
1010600CP	6"	3/4"	11-3/16"	1-9/16"	630

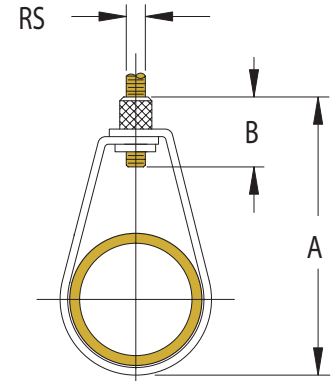

SWIVEL LOOP HANGER 100FL

Felt-lined Adjustable Band Hanger

- Size Range: 1/2" through 4"
- Surface Finish: Electro-zinc plated
- Recommended for the suspension of stationary non-insulated copper tubing lines to prevent electrolysis
- Felt lining also acts to reduce noise in pipes
- Conforms with Federal Specification WW-H-171 (Type 10), Manufacturers Standardization Society (MSS) SP-58 and SP-69 (Type 10)



Part Number	Nominal Pipe Size	RS	A	B	Max. Rec. Load (lbs)
1000050FL	1/2"	3/8"	2-3/4"	1"	300
1000075FL	3/4"	3/8"	3-1/16"	1"	300
1000100FL	1"	3/8"	3-5/16"	1"	300
1000125FL	1-1/4"	3/8"	3-9/16"	1"	300
1000150FL	1-1/2"	3/8"	3-13/16"	1"	300
1000200FL	2"	3/8"	4-1/4"	1"	300
1000250FL	2-1/2"	1/2"	5-5/8"	1-1/4"	1000
1000300FL	3"	1/2"	6-9/16"	1-1/4"	1000
1000350FL	3-1/2"	1/2"	7"	1-1/4"	1000
1000400FL	4"	5/8"	7-3/4"	1-5/16"	1100

3/4" - 8" 1/2" - 8"

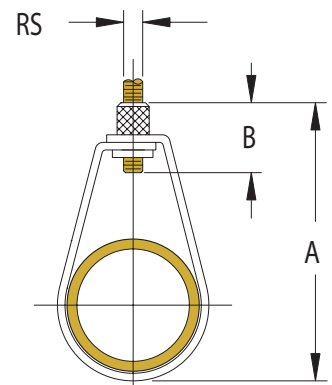

SWIVEL LOOP HANGER 102

PVC Coated Adjustable Band Hanger

- Size Range: 1/2" through 8"
- Surface Finish: Electro-zinc plated with a vinyl top coat
- Recommended for the suspension of stationary non-insulated pipe lines
- Conforms with Federal Specification WW-H-171 (Type 10), Manufacturers Standardization Society (MSS) SP-58 and SP-69 (Type 10)



Part Number	Nominal Pipe Size	RS	A	B	Max. Rec. Load (lbs)
1020050VC	1/2"	3/8"	3-1/8"	1"	300
1020075VC	3/4"	3/8"	3-1/16"	1"	300
1020100VC	1"	3/8"	3-3/16"	1"	300
1020125VC	1-1/4"	3/8"	3-1/2"	1"	300
1020150VC	1-1/2"	3/8"	3-15/16"	1"	300
1020200VC	2"	3/8"	4-1/2"	1"	300
1020250VC	2-1/2"	1/2"	5-5/8"	1-1/4"	1000
1020300VC	3"	1/2"	6-9/16"	1-1/4"	1000
1020350VC	3-1/2"	1/2"	7"	1-1/4"	1000
1020400VC	4"	5/8"	7-3/4"	1-5/16"	1100
1020500VC	5"	5/8"	9-1/8"	1-5/16"	1100
1020600VC	6"	3/4"	10-5/8"	1-9/16"	1250
1020800VC	8"	7/8"	13-1/8"	1-5/8"	1250

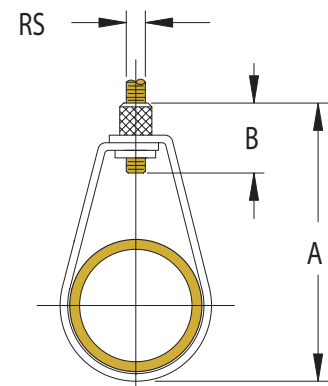

SWIVEL LOOP HANGER 102A

PVC Coated Adjustable Band Hanger for Copper Tubing

- Size Range: 1/2" through 6"
- Surface Finish: Copper colored coating with a vinyl top coat
- Recommended for the suspension of stationary non-insulated copper tubing lines where it is undesirable to have the steel of the hanger in direct contact with the copper tubing
- Conforms with Federal Specification WW-H-171 (Type 10), Manufacturers Standardization Society (MSS) SP-58 and SP-69 (Type 10)



Part Number	Nominal Pipe Size	RS	A	B	Max. Rec. Load (lbs)
102A0050VC	1/2 "	3/8 "	3-3/16"	1"	180
102A0075VC	3/4 "	3/8 "	3-1/8"	1"	180
102A0100VC	1 "	3/8 "	3-1/8"	1"	180
102A0125VC	1-1/4 "	3/8 "	3-3/16"	1"	180
102A0150VC	1-1/2 "	3/8 "	3-5/8"	1"	180
102A0200VC	2 "	3/8 "	3-13/16"	1"	180
102A0250VC	2-1/2 "	1/2 "	4-7/16"	1"	200
102A0300VC	3 "	1/2 "	5-11/16"	1-1/4"	250
102A0350VC	3-1/2 "	1/2 "	6-7/16"	1-1/4"	300
102A0400VC	4 "	1/2 "	7-1/8"	1-1/4"	360
102A0500VC	5 "	5/8 "	9-1/4"	1-5/16"	480
102A0600VC	6 "	3/4 "	11-3/16"	1-9/16"	630

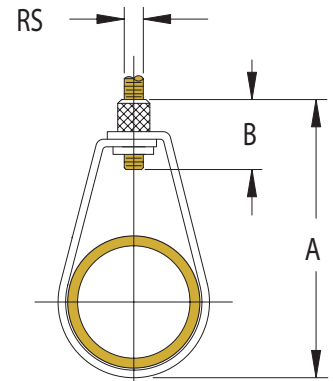

SWIVEL LOOP HANGER 103

Adjustable Band Hanger with Insulation Shield

- Size Range: 1-1/2" through 6"
- Surface Finish: Electro-zinc plated
- Recommended for the suspension of stationary low or high temperature piping where crush resistant material is installed at the point of support
- Protection shield is welded to loop before plating
- Flared edges on sizes through 4" only
- For sizes larger than 6" see Model 403 Clevis Hanger



Part Number	Nominal Pipe Size	RS	A	B	C	Max. Rec. Load (lbs)
1030150EG	1-1/2 "	3/8 "	3-13/16 "	1 "	3 "	300
1030200EG	2 "	3/8 "	4-1/4 "	1 "	3 "	300
1030250EG	2-1/2 "	1/2 "	5-5/8 "	1-1/4 "	4 "	1000
1030300EG	3 "	1/2 "	6-9/16 "	1-1/4 "	4 "	1000
1030350EG	3-1/2 "	1/2 "	7 "	1-1/4 "	4 "	1000
1030400EG	4 "	5/8 "	7-3/4 "	1-5/16 "	6 "	1100
1030500EG	5 "	5/8 "	9-1/8 "	1-5/16 "	6 "	1100
1030600EG	6 "	3/4 "	10-5/8 "	1-9/16 "	6 "	1250

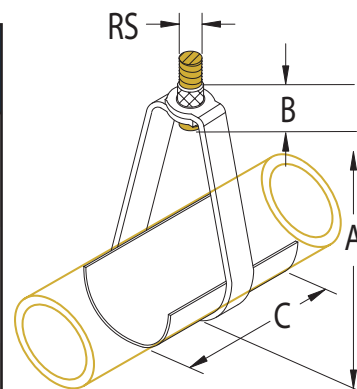

Flared edges on sizes thru 4" only.
Insulation not included.



SWIVEL LOOP HANGER 104

Adjustable Band Hanger for Plastic Pipe

- Size Range: 1/2" through 4"
- Surface Finish: Electro-zinc plated
- Recommended for the suspension of stationary flexible EPDM or Polypropylene plastic piping
- Use hanger with V-trough (model VTR) for continuous support of flexible or hot piping services



Part Number	Size No.	Nominal Pipe Size	RS	A	B	Max. Rec. Load (lbs)
1040100EG	1	1/2"	3/8"	5-7/8"	7/8"	175
1040100EG	1	3/4"	3/8"	5-7/8"	7/8"	175
1040100EG	1	1"	3/8"	5-7/8"	7/8"	175
1040100EG	1	1-1/4"	3/8"	5-7/8"	7/8"	175
1040100EG	1	1-1/2"	3/8"	5-7/8"	7/8"	175
1040100EG	1	2"	3/8"	5-7/8"	7/8"	175
1040200EG	2	2-1/2"	1/2"	9-1/4"	1-1/8"	175
1040200EG	2	3"	1/2"	9-1/4"	1-1/8"	175
1040200EG	2	3-1/2"	1/2"	9-1/4"	1-1/8"	175
1040200EG	2	4"	1/2"	9-1/4"	1-1/8"	175

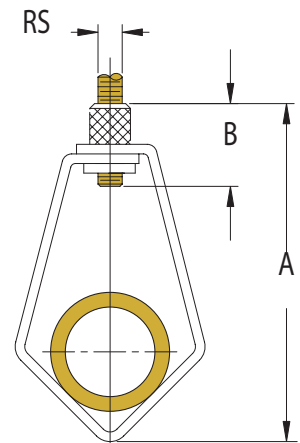

CONTINUOUS SUPPORT VTR

V-trough Support for Flexible or Hot Piping Services

- Surface Finish: Electro-zinc plated
- Used with the model 104 Hanger for continuous support of flexible or hot piping services

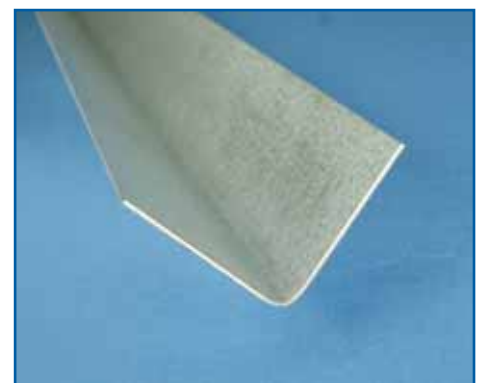

Part Number	Nominal Pipe Size	Size
VTR#11000	1/2" thru 2"	#1
VTR#21000	2-1/2" thru 4"	#2

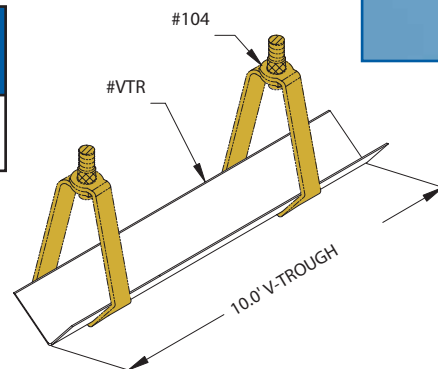

J-HANGER 418

Galvanized J-hanger

- Size Range: 1/2" through 8"
- Surface Finish: Electro-zinc plated
- Recommended for the suspension of stationary non-insulated pipe lines
- T-slot hole for bolt head permits disengagement of side bolt without removing the nut (sizes 1/2" thru 4" only)
- Side hole permits wall mounting (sizes 1/2" thru 4" only)
- Conforms Manufacturers Standardization Society (MSS) SP-58 and SP-69 (Type 5)



Part Number	Nominal Pipe Size	RS	A	B	Max. Rec. Load (lbs)
4180050EG	1/2"	3/8"	3"	9/16"	400
4180075EG	3/4"	3/8"	3-3/8"	9/16"	400
4180100EG	1"	3/8"	3-11/16"	9/16"	400
4180125EG	1-1/4"	3/8"	4-1/2"	9/16"	400
4180150EG	1-1/2"	3/8"	4-13/16"	9/16"	400
4180200EG	2"	3/8"	5-11/16"	9/16"	400
4180250EG	2-1/2"	1/2"	6-3/4"	11/16"	800
4180300EG	3"	1/2"	7-11/16"	11/16"	800
4180350EG	3-1/2"	1/2"	8-3/8"	11/16"	800
4180400EG	4"	5/8"	9-3/16"	13/16"	800
4180500EG	5"	5/8"	10"	13/16"	800
4180600EG	6"	3/4"	11-5/8"	15/16"	1000
4180800EG	8"	3/4"	14-1/16"	1-1/16"	1200

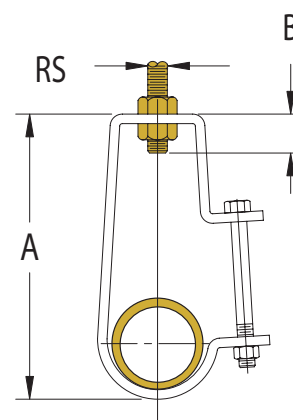

J-HANGER 418FL

Galvanized Felt-lined J-hanger

- Size Range: 1/2" through 4"
- Surface Finish: Electro-zinc plated
- Recommended for the suspension of stationary non-insulated pipe lines
- Felt lining also acts to reduce noise in pipes
- T-slot hole for bolt head permits disengagement of side bolt without removing the nut
- Side hole permits wall mounting
- Conforms Manufacturers Standardization Society (MSS) SP-58 and SP-69 (Type 5)



Part Number	Nominal Pipe Size	RS	A	B	Max. Rec. Load (lbs)
4180050FL	1/2"	3/8"	3"	9/16"	400
4180075FL	3/4"	3/8"	3-3/8"	9/16"	400
4180100FL	1"	3/8"	3-11/16"	9/16"	400
4180125FL	1-1/4"	3/8"	4-1/2"	9/16"	400
4180150FL	1-1/2"	3/8"	4-13/16"	9/16"	400
4180200FL	2"	3/8"	5-1/16"	9/16"	400
4180250FL	2-1/2"	1/2"	6-3/4"	11/16"	800
4180300FL	3"	1/2"	7-11/16"	11/16"	800
4180350FL	3-1/2"	1/2"	8-9/16"	11/16"	800
4180400FL	4"	5/8"	9-3/16"	13/16"	800

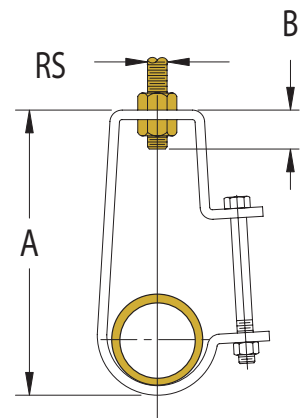

NEW Products



CADDY® EZ RISER

- Recommended for suspending vertical steel pipe risers
- Slotted holes make assembly a snap – no fumbling with loose hardware
- Bolts are accessible from the front, serrated washer head design means no wrench required on back side for tightening

See page 32



NEW



Page 32

CADDY® EZ RISER



Page 33

510RO



Page 34

511



Page 35

520



Page 36

450



Page 37

451



Page 38

452



Page 39

453



Page 40

700



Page 41

705



Page 42

517



Page 42

516

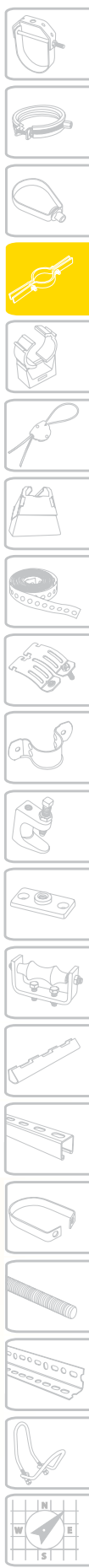

CADDY® EZ RISER

Vertical Pipe Support

- Size Range: 1/2" through 24"
- Surface Finish: Electro-zinc plated
- Recommended for suspending vertical steel pipe risers
- Slotted holes make assembly a snap – no fumbling with loose hardware
- Bolts are accessible from the front, serrated washer head design means no wrench required on back side for tightening
- Standard electro-zinc plated finish is cleaner, provides superior corrosion protection
- Conforms with Federal Specification WW-H-171 (Type 8), Manufacturers Standardization Society (MSS) SP-58 and SP-69 (Type 8)



NOTE: Clamp is fitted for steel pipe and should be installed below a coupling or shear lug, with bolts torqued to recommended value

Part Number	Nominal Pipe Size	A	B	HS	Max. Rec. Load (lbs)
5100050EG	1/2"	8-1/2"	1"	7/16"	255
5100075EG	3/4"	9"	1"	7/16"	255
5100100EG	1"	9"	1"	7/16"	255
5100125EG	1-1/4"	9-7/16"	1"	7/16"	255
5100150EG	1-1/2"	9-7/8"	1"	7/16"	255
5100200EG	2"	10-1/4"	1-3/16"	7/16"	255
5100250EG	2-1/2"	11"	1-3/16"	7/16"	390
5100300EG	3"	11-3/4"	1-3/16"	7/16"	530
5100350EG	3-1/2"	12-5/8"	1-3/16"	9/16"	670
5100400EG	4"	13"	1-1/2"	9/16"	810
5100500EG	5"	14-1/2"	1-1/2"	9/16"	1160
5100600EG	6"	16"	2"	9/16"	1570
5100800EG	8"	18-1/4"	2"	11/16"	2500
5101000EG	10"	20-5/8"	2"	11/16"	2500
5101200EG	12"	22-3/8"	2"	11/16"	2700
5101400EG	14"	24-1/8"	2"	11/16"	2700
5101600EG	16"	27-7/8"	2-1/2"	13/16"	2900
5101800EG	18"	29-13/16"	2-1/2"	13/16"	2900
5102000EG	20"	32-1/4"	2-1/2"	13/16"	2900
5102400EG	24"	36-1/8"	3"	15/16"	2900

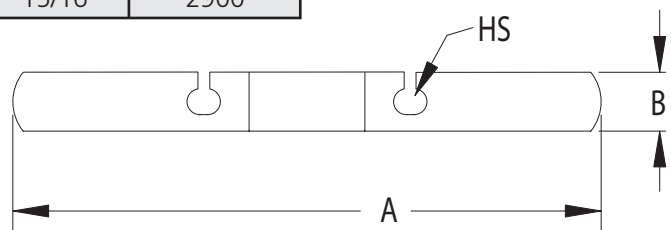
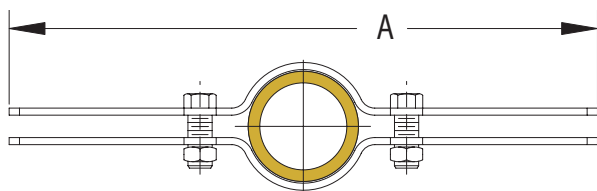

RISER CLAMP 510RO

Vertical Pipe Support with Red Oxide Coating

- Size Range: 1/2" through 12"
- Surface Finish: Red-oxide primer coating
- Recommended for suspending vertical steel pipe risers
- Conforms with Federal Specification WW-H-171 (Type 8), Manufacturers Standardization Society (MSS) SP-58 and SP-69 (Type 8)



NOTE: Clamp is fitted for steel pipe and should be installed below a coupling or shear lug, with bolts torqued to recommended value

Part Number	Nominal Pipe Size	A	B	HS	Max. Rec. Load (lbs)
5100050RO	1/2"	8-1/2"	1"	7/16"	255
5100075RO	3/4"	9"	1"	7/16"	255
5100100RO	1"	9"	1"	7/16"	255
5100125RO	1-1/4"	9-7/16"	1"	7/16"	255
5100150RO	1-1/2"	9-7/8"	1"	7/16"	255
5100200RO	2"	10-1/4"	1-3/16"	7/16"	255
5100250RO	2-1/2"	11"	1-3/16"	7/16"	390
5100300RO	3"	11-3/4"	1-3/16"	7/16"	530
5100350RO	3-1/2"	12-5/8"	1-3/16"	9/16"	670
5100400RO	4"	13"	1-1/2"	9/16"	810
5100500RO	5"	14-1/2"	1-1/2"	9/16"	1160
5100600RO	6"	16"	2"	9/16"	1570
5100800RO	8"	18-1/4"	2"	11/16"	2500
5101000RO	10"	20-5/8"	2"	11/16"	2500
5101200RO	12"	22-3/8"	2"	11/16"	2700

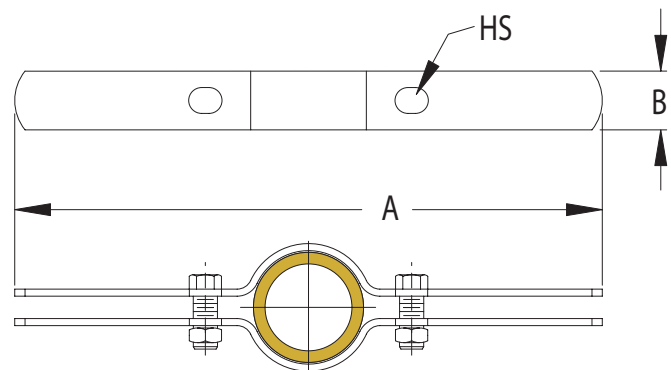

RISER CLAMP 511

Vertical Support for Copper Tubing

- Size Range: 1/2" through 6"
- Surface Finish: Copper-colored coating (for identification purposes only)
- Recommended for suspending vertical type K or L copper tubing risers
- Conforms with Federal Specification WW-H-171 (Type 8), Manufacturers Standardization Society (MSS) SP-58 and SP-69 (Type 8)

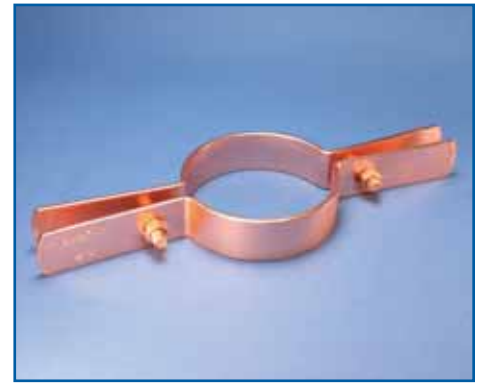

NOTE: Clamp is fitted for steel pipe and should be installed below a coupling or shear lug, with bolts torqued to recommended value

Part Number	Nominal Pipe Size	A	B	HS	Max. Rec. Load (lbs)
5110050CP	1/2"	8-1/2"	1"	7/16"	75
5110075CP	3/4"	9-1/4"	1"	7/16"	75
5110100CP	1"	9-1/4"	1"	7/16"	120
5110125CP	1-1/4"	9-1/2"	1-1/4"	7/16"	150
5110150CP	1-1/2"	9-1/2"	1-1/4"	7/16"	150
5110200CP	2"	10-3/8"	1-1/4"	7/16"	150
5110250CP	2-1/2"	11"	1-1/4"	7/16"	300
5110300CP	3"	12"	1-1/4"	7/16"	300
5110400CP	4"	12-1/2"	1-1/4"	7/16"	300
5110500CP	5"	14-5/8"	1-1/2"	9/16"	500
5110600CP	6"	15"	2"	9/16"	600

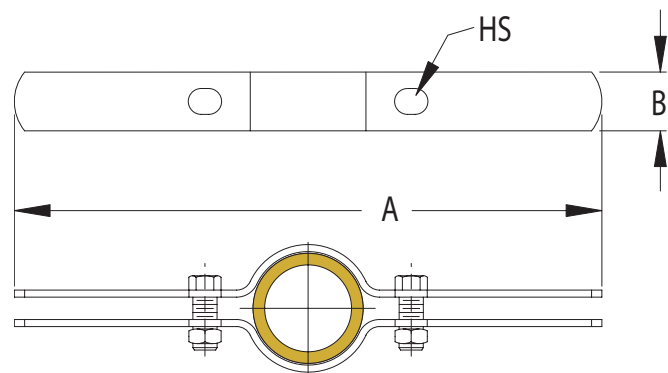

RISER CLAMP 520

Vertical Pipe Support with Epoxy Coating

- Size Range: 1/2" through 8"
- Surface Finish: Epoxy Coated
- Recommended for suspending vertical steel pipe risers where it is undesirable to have the steel of the hanger in direct contact with the pipe
- Conforms with Federal Specification WW-H-171 (Type 8), Manufacturers Standardization Society (MSS) SP-58 and SP-69 (Type 8)



NOTE: Clamp is fitted for steel pipe and should be installed below a coupling or shear lug, with bolts torqued to recommended value

Part Number	Nominal Pipe Size	A	B	HS	Max. Rec. Load (lbs)
5200050EP	1/2"	8-1/2"	1"	7/16"	255
5200075EP	3/4"	9"	1"	7/16"	255
5200100EP	1"	9"	1"	7/16"	255
5200125EP	1-1/4"	9-7/16"	1"	7/16"	255
5200150EP	1-1/2"	9-7/8"	1"	7/16"	255
5200200EP	2"	10-1/4"	1-3/16"	7/16"	255
5200250EP	2-1/2"	11"	1-3/16"	7/16"	390
5200300EP	3"	11-3/4"	1-3/16"	7/16"	530
5200400EP	4"	13"	1-1/2"	9/16"	810
5200500EP	5"	14-1/2"	1-1/2"	9/16"	1160
5200600EP	6"	16"	2"	9/16"	1570
5200800EP	8"	18-1/4"	2"	11/16"	2500

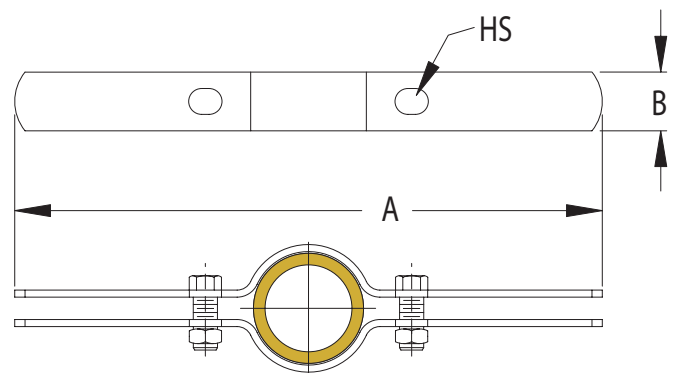

STANDARD PIPE CLAMP 450

Standard Duty

- Size Range: 1/2" through 30"
- Surface Finish: Black
- Industrial pipe hanger for hot or cold service where no insulation is required
- Normally used in conjunction with a #40 Eye Rod or a #35 Forged Steel Eye Nut
- Conforms with Federal Specification WW-H-171 (Type 4), Manufacturers Standardization Society (MSS) SP-58 and SP-69 (Type 4)



Part Number	Nominal Pipe Size	A	B	BS	Max. Rec. Load (lbs)
4500050PL	1/2"	3-1/16"	7/16"	5/16"	500
4500075PL	3/4"	3-5/16"	7/16"	5/16"	500
4500100PL	1"	3-11/16"	7/16"	5/16"	500
4500125PL	1-1/4"	3-15/16"	7/16"	5/16"	500
4500150PL	1-1/2"	4-7/16"	5/8"	5/16"	800
4500200PL	2"	5-3/8"	5/8"	1/2"	1040
4500250PL	2-1/2"	6-3/8"	5/8"	1/2"	1040
4500300PL	3"	7-1/8"	5/8"	1/2"	1040
4500350PL	3-1/2"	7-1/2"	5/8"	1/2"	1040
4500400PL	4"	8-3/4"	5/8"	5/8"	1040
4500500PL	5"	9-11/16"	5/8"	5/8"	1040
4500600PL	6"	11-5/8"	7/8"	3/4"	1615
4500800PL	8"	13-7/8"	1"	3/4"	1615
4501000PL	10"	17-1/8"	1"	7/8"	2490
4501200PL	12"	19-1/8"	1"	7/8"	2490
4501400PL	14"	21-1/4"	1-1/8"	7/8"	2490
4501600PL	16"	23-1/4"	1-1/8"	7/8"	2490
4501800PL	18"	26"	1-1/4"	1"	3060
4502000PL	20"	28-1/4"	1-3/8"	1-1/8"	3060
4502400PL	24"	33-3/4"	1-5/8"	1-1/4"	3060
4503000PL	30"	42"	2"	1-3/4"	3500

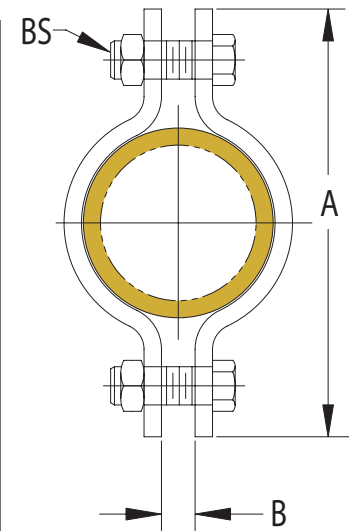

STANDARD PIPE CLAMP 451

Heavy Duty

- Size Range: 3" through 24"
- Surface Finish: Black
- Industrial pipe hanger for hot or cold service where no insulation is required
- Normally used in conjunction with a #40 Eye Rod or a #35 Forged Steel Eye Nut
- Conforms with Federal Specification WW-H-171 (Type 4), Manufacturers Standardization Society (MSS) SP-58 and SP-69 (Type 4)



Part Number	Nominal Pipe Size	A	B	BS	Max. Rec. Load (lbs)
4510300EG	3"	8"	1"	3/4"	3370
4510400EG	4"	9-3/4"	1"	7/8"	3515
4510500EG	5"	11"	1"	7/8"	3515
4510600EG	6"	13-1/4"	1-1/8"	1"	4865
4510800EG	8"	15-1/4"	1-1/8"	1"	4865
4511000EG	10"	18-1/8"	1-1/4"	1-1/4"	6010
4511200EG	12"	21-3/4"	1-5/8"	1-1/2"	8675
4511400EG	14"	23-3/4"	1-5/8"	1-1/2"	9120
4511600EG	16"	25-3/4"	1-5/8"	1-1/2"	9120
4511800EG	18"	38-1/2"	3"	2"	13800
4512000EG	20"	42-1/8"	3"	2"	15300
4512400EG	24"	48-1/4"	3-1/4"	2-1/4"	16300

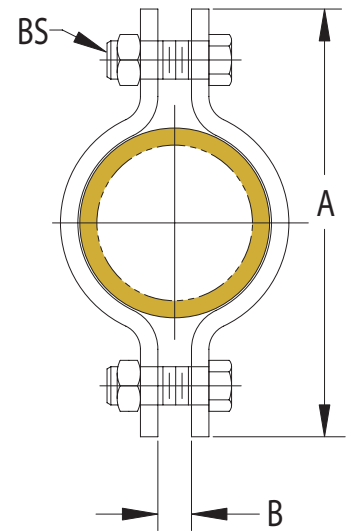

STANDARD PIPE CLAMP 452

Double Bolt Pipe Clamp

- Size Range: 1/2" through 24"
- Surface Finish: Black
- Industrial pipe hanger for hot service with up to 4" of insulation and where flexibility at rod attachment is desired
- Load bolt will extend past 4" of insulation on pipe sizes 6" and larger
- Normally used in conjunction with a #40 Eye Rod or a #35 Forged Steel Eye Nut
- Conforms with Federal Specification WW-H-171 (Type 3), Manufacturers Standardization Society (MSS) SP-58 and SP-69 (Type 3)



Part Number	Nominal Pipe Size	A	B	BS	Max. Rec. Load (lbs)
4520050PL	1/2"	4-1/2"	5/8"	3/8"	850
4520075PL	3/4"	5-7/16"	5/8"	3/8"	850
4520100PL	1"	5-1/2"	5/8"	3/8"	850
4520125PL	1-1/4"	5-5/8"	5/8"	3/8"	850
4520150PL	1-1/2"	7-7/8"	1"	5/8"	1380
4520200PL	2"	8-1/8"	1"	5/8"	1380
4520250PL	2-1/2"	8-3/4"	1"	5/8"	1380
4520300PL	3"	9-3/8"	1"	5/8"	1380
4520400PL	4"	12-1/8"	1-1/16"	3/4"	2230
4520500PL	5"	13-1/8"	1-1/16"	3/4"	2230
4520600PL	6"	16"	1-7/16"	1"	2555
4520800PL	8"	18-1/16"	1-7/16"	1"	2555
4521000PL	10"	20-7/8"	1-7/16"	1"	2890
4521200PL	12"	22-7/8"	1-7/16"	1"	2890
4521400PL	14"	25-5/16"	2"	1-1/4"	3835
4521600PL	16"	27-5/16"	2"	1-1/4"	3835
4521800PL	18"	29-5/16"	2"	1-1/4"	3835
4522000PL	20"	31-15/16"	2"	1-1/2"	4015
4522400PL	24"	35-15/16"	2"	1-1/2"	4900

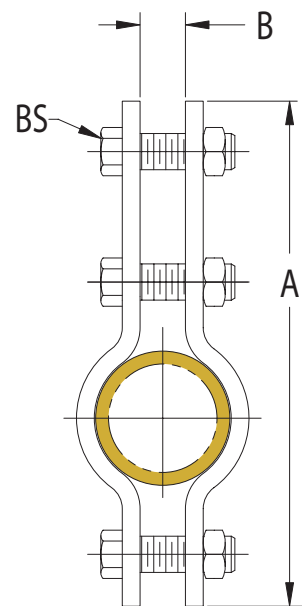

STANDARD PIPE CLAMP 453

Heavy Duty Double Bolt Pipe Clamp

- Size Range: 6" through 24"
- Surface Finish: Black
- Industrial heavy load pipe hanger for hot service with up to 4" of insulation and where flexibility at rod attachment is desired
- Load bolt will extend past 4" of insulation
- Normally used in conjunction with a #40 Eye Rod or a #35 Forged Steel Eye Nut
- Conforms with Federal Specification WW-H-171 (Type 3), Manufacturers Standardization Society (MSS) SP-58 and SP-69 (Type 3)



Part Number	Nominal Pipe Size	A	B	BS	Max. Rec. Load (lbs)
4530600PL	6"	16-1/4"	1-3/4"	1"	3125
4530800PL	8"	18-5/8"	2"	1-1/8"	4285
4531000PL	10"	22-1/8"	2-1/4"	1-1/4"	4910
4531200PL	12"	25-3/4"	2-1/2"	1-1/2"	6250
4531400PL	14"	27-5/8"	2-1/2"	1-1/2"	8485
4531600PL	16"	30-1/4"	3"	1-3/4"	8930
4531800PL	18"	34-3/4"	3-1/2"	2"	12325
4532000PL	20"	36-3/4"	3-1/2"	2"	13665
4532400PL	24"	42-1/4"	3-1/2"	2"	14555

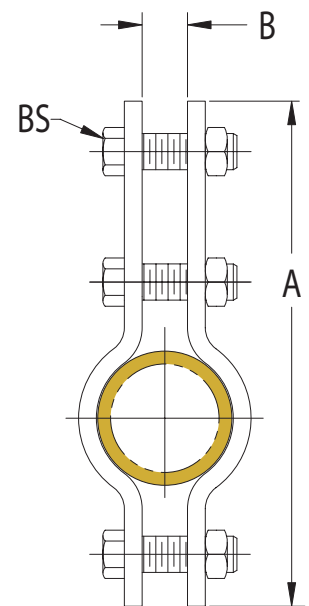

STANDARD PIPE CLAMP 700

Offset Pipe Clamp

- Size Range: 1/2" through 8"
- Surface Finish: Black
- Industrial pipe hanger to support piping away from wall or floor



Part Number	Nominal Pipe Size	A	B	HS	Max. Rec. Load (lbs)
7000050PL	1/2"	9-3/4"	3-3/8"	3/8"	190
7000075PL	3/4"	8-7/16"	3-5/16"	3/8"	200
7000100PL	1"	9-1/16"	3-9/16"	3/8"	200
7000125PL	1-1/4"	9-3/8"	3-15/16"	3/8"	200
7000150PL	1-1/2"	9-3/4"	4-1/8"	3/8"	200
7000200PL	2"	10-5/8"	4-5/8"	3/8"	410
7000250PL	2-1/2"	11-5/8"	5-1/8"	3/8"	410
7000300PL	3"	12-7/8"	5-3/4"	3/8"	410
7000400PL	4"	14-1/2"	6-3/4"	1/2"	600
7000500PL	5"	15-3/4"	7-13/16"	1/2"	600
7000600PL	6"	18-1/4"	9"	1/2"	850
7000800PL	8"	20-5/8"	11"	1/2"	850

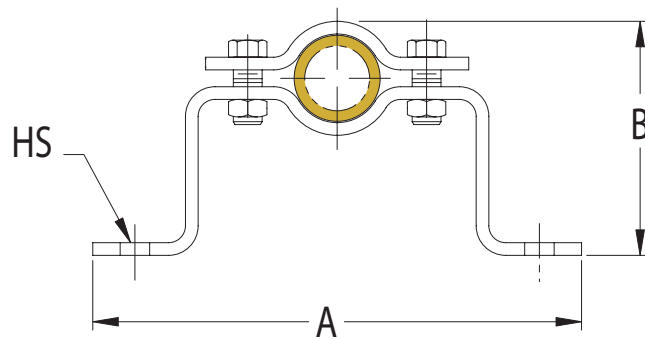

STANDARD PIPE CLAMP 705

Extended Pipe Clamp

- Size Range: 1/2" through 8"
- Surface Finish: Black
- Industrial pipe hanger for field fabrication during installation of pipe, when specific center line distances are unknown
- Legs may also be welded to the structure



Part Number	Nominal Pipe Size	A	B
7050050PL	1/2 "	4-3/16 "	12-9/16 "
7050075PL	3/4 "	4-15/16 "	12-11/16 "
7050100PL	1 "	5-3/16 "	12-7/8 "
7050125PL	1-1/4 "	5-1/2 "	13 "
7050150PL	1-1/2 "	5-3/4 "	13-1/8 "
7050200PL	2 "	6-1/2 "	13-7/16 "
7050250PL	2-1/2 "	7-3/4 "	13-11/16 "
7050300PL	3 "	8-3/8 "	14 "
7050350PL	3-1/2 "	8-7/8 "	14-1/4 "
7050400PL	4 "	9-3/4 "	14-1/2 "
7050500PL	5 "	11 "	15 "
7050600PL	6 "	13-1/4 "	15-11/16 "
7050800PL	8 "	15-3/8 "	16-1/16 "

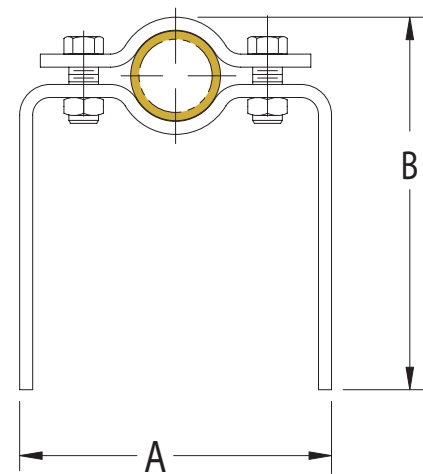

SOCKET CLAMP 517

- Size Range: 3" through 24"
- Surface Finish: Black
- Industrial pipe hanger used to prevent separation of caulked or rubber joints on AWWA cast iron water main pipes
- One clamp is used on each side of the joint being restrained
- Must use threaded rod with hex nuts to connect the two clamps utilizing model #516 Socket Clamp Washers



Part Number	Nominal Pipe Size	A	HS
5170300PL	3"	10-7/8"	3/4"
5170400PL	4"	12-1/8"	3/4"
5170600PL	6"	14-3/8"	3/4"
5170800PL	8"	16-5/8"	3/4"
5171000PL	10"	18-7/8"	3/4"
5171200PL	12"	21-1/4"	3/4"
5171400PL	14"	25-1/2"	1-1/4"
5171600PL	16"	28"	1-1/4"
5171800PL	18"	31-1/2"	1-1/4"
5172000PL	20"	33-3/4"	1-3/8"
5172400PL	24"	39-3/4"	1-1/2"

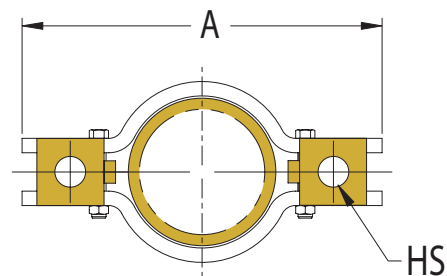

SOCKET CLAMP WASHER 516

- Surface Finish: Black
- Used with model #517 Socket Clamp

Part Number	HS
5160075PL	7/8"
5160125PL	1-3/8"
5160137PL	1-1/2"
5160150PL	1-5/8"

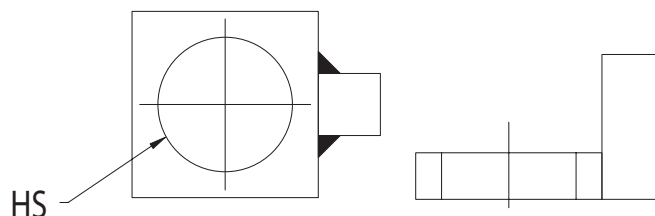



Page 45

007



Page 45

STR



Page 46

008



Page 47

STR2



Page 47

470



Page 48

008CP



Page 48

008CU



Page 49

U-Hanger



Page 49

DWV



Page 50

WH



Page 51

TPC



Page 51

CADDY® SUPERKLIP



Page 52

SMS8



Page 52

SGB



Page 52

TSGB



Page 53

150M



Page 54

M-Series



Page 54

MCP-Series



Page 55

M-Series



Page 56

MCP-Series



Page 57

CD-Series



Page 58

CDCP-Series



Page 59

801



Page 59

800



Page 60

802



Page 60

EPS



PIPE FIXINGS 007

One-hole Strap

- Size Range: 1/2" through 2"
- Surface Finish: Electro-zinc plated
- Recommended for supporting horizontal runs of piping from the face of a structural member
- Fastening hole in strap may be above or below pipe

Part Number	Nominal Pipe Size	A	B	HS
0070050EG	1/2"	1-1/8"	5/8"	1/4"
0070075EG	3/4"	1-1/4"	5/8"	1/4"
0070100EG	1"	1-3/8"	5/8"	1/4"
0070125EG	1-1/4"	1-9/16"	7/8"	1/4"
0070150EG	1-1/2"	1-11/16"	7/8"	1/4"
0070200EG	2"	1-15/16"	7/8"	1/4"

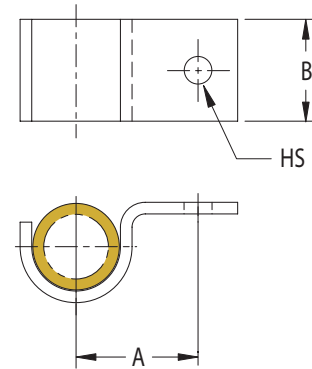

PIPE FIXINGS STR

One-hole Strap for Strut

- Size Range: 1/4" through 1"
- Surface Finish: Electro-zinc plated
- Recommended for supporting horizontal runs of piping from CADDY® ERISTRUT channel

Part Number	Nominal Pipe Size	A	HS
STR0025EG	1/4"	11/16"	9/32"
STR0037EG	3/8"	3/4"	9/32"
STR0050EG	1/2"	13/16"	9/32"
STR0062EG	5/8"	7/8"	9/32"
STR0075EG	3/4"	15/16"	9/32"
STR0087EG	7/8"	1"	9/32"
STR0100EG	1"	1-1/8"	9/32"

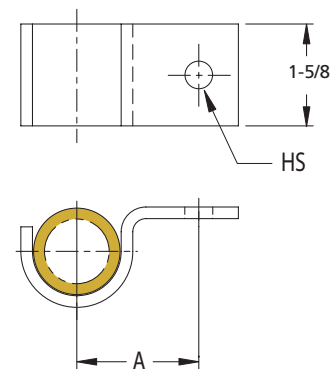

PIPE FIXINGS 008

Two-hole Strap

- Size Range: 1/4" through 4"
- Surface Finish: Electro-zinc plated
- Light duty support of pipe
- Attaches directly to the face of a horizontal or vertical structural member
- Conforms with Federal Specification WW-H-171 (Type 26), Manufacturers Standardization Society (MSS) SP-58 and SP-69 (Type 26)



Part Number	Nominal Pipe Size	A	B	HS
0080025EG	1/4"	15/16"	5/8"	1/4"
0080037EG	3/8"	1"	5/8"	1/4"
0080050EG	1/2"	1-1/8"	5/8"	1/4"
0080075EG	3/4"	1-1/4"	3/4"	1/4"
0080100EG	1"	1-3/8"	3/4"	1/4"
0080125EG	1-1/4"	1-1/2"	7/8"	1/4"
0080150EG	1-1/2"	1-5/8"	1-1/4"	1/4"
0080200EG	2"	1-7/8"	1-1/4"	1/4"
0080250EG	2-1/2"	2-1/8"	1-1/4"	1/4"
0080300EG	3"	3-3/16"	1-1/4"	1/4"
0080400EG	4"	3-1/2"	1-1/4"	1/4"

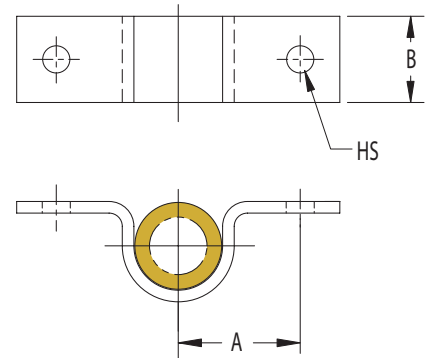

PIPE FIXINGS STR2

Two-hole Strap for Strut

- Size Range: 1/2" through 6"
- Surface Finish: Electro-zinc plated
- Recommended for supporting horizontal runs of piping from CADDY® ERISTRUT channel
- Conforms with Federal Specification WW-H-171 (Type 26), Manufacturers Standardization Society (MSS) SP-58 and SP-69 (Type 26)

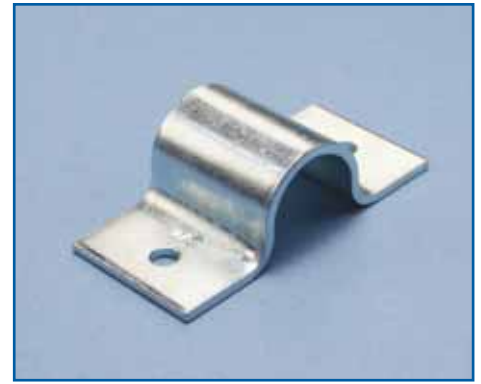

Part Number	Nominal Pipe Size	A	HS
STR20050EG	1/2"	1-1/16"	9/32"
STR20075EG	3/4"	1-3/16"	9/32"
STR20100EG	1"	1-3/8"	9/32"
STR20125EG	1-1/4"	1-7/16"	9/32"
STR20150EG	1-1/2"	1-1/2"	9/32"
STR20200EG	2"	2-11/16"	7/16"
STR20250EG	2-1/2"	2-7/8"	7/16"
STR20300EG	3"	3-5/16"	7/16"
STR20350EG	3-1/2"	3-11/16"	7/16"
STR20400EG	4"	3-13/16"	7/16"
STR20500EG	5"	4-7/16"	7/16"
STR20600EG	6"	5-1/16"	7/16"

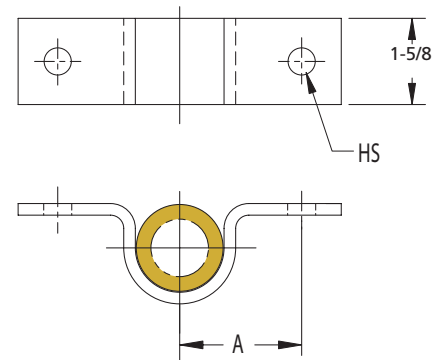

PIPE FIXINGS 470

Short Clip

- Size Range: 1/2" through 4"
- Surface Finish: Black
- Recommended for supporting pipe runs close to a ceiling or wall
- Conforms with Federal Specification WW-H-171 (Type 26), Manufacturers Standardization Society (MSS) SP-58 and SP-69 (Type 26)



Part Number	Nominal Pipe Size	A	B	HS	Max. Rec. Load (lbs)
4700050PL	1/2"	1-7/16"	1-1/4"	7/16"	300
4700075PL	3/4"	1-9/16"	1-1/4"	7/16"	300
4700100PL	1"	1-11/16"	1-1/4"	7/16"	300
4700125PL	1-1/4"	1-7/8"	1-1/4"	7/16"	300
4700150PL	1-1/2"	2"	1-1/4"	7/16"	300
4700200PL	2"	2-1/4"	1-1/4"	7/16"	300
4700250PL	2-1/2"	2-1/2"	1-1/4"	7/16"	500
4700300PL	3"	2-13/16"	1-1/4"	7/16"	500
4700400PL	4"	3-9/16"	1-1/2"	9/16"	500

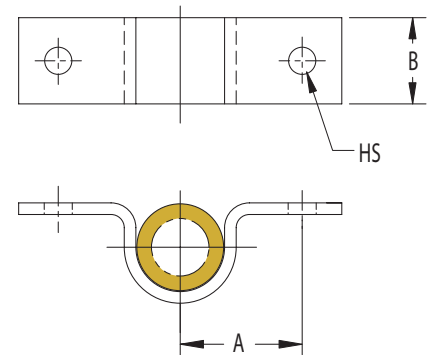

PIPE FIXINGS 008CP

Two-hole Strap for Copper Tubing

- Size Range: 1/4" through 2"
- Surface Finish: Copper colored coating (for identification purposes only)
- Light duty support of copper tubing
- Attaches directly to the face of a horizontal or vertical structural member
- Conforms with Federal Specification WW-H-171 (Type 26), Manufacturers Standardization Society (MSS) SP-58 and SP-69 (Type 26)



Part Number	Nominal Pipe Size	A	B	HS
0080025CP	1/4"	15/16"	5/8"	1/4"
0080037CP	3/8"	1"	5/8"	1/4"
0080050CP	1/2"	1-1/8"	5/8"	1/4"
0080075CP	3/4"	1-1/4"	3/4"	1/4"
0080100CP	1"	1-3/8"	3/4"	1/4"
0080125CP	1-1/4"	1-1/2"	7/8"	1/4"
0080150CP	1-1/2"	1-5/8"	1-1/4"	1/4"
0080200CP	2"	1-7/8"	1-1/4"	1/4"

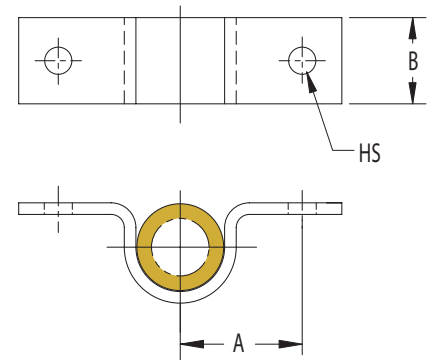

PIPE FIXINGS 008CU

Two-hole Copper Strap for Copper Tubing – Solid Copper

- Size Range: 1/4" through 2"
- Surface Finish: Plain
- Light duty solid copper strap support for copper tubing
- Attaches directly to the face of a horizontal or vertical structural member
- Conforms with Federal Specification WW-H-171 (Type 26), Manufacturers Standardization Society (MSS) SP-58 and SP-69 (Type 26)



Part Number	Nominal Pipe Size	A	B	HS
008CU0025PL	1/4"	7/8"	5/8"	1/4"
008CU0037PL	3/8"	15/16"	5/8"	1/4"
008CU0050PL	1/2"	1"	5/8"	1/4"
008CU0075PL	3/4"	1-1/8"	3/4"	1/4"
008CU0100PL	1"	1-1/4"	3/4"	1/4"
008CU0125PL	1-1/4"	1-3/8"	7/8"	1/4"
008CU0150PL	1-1/2"	1-1/2"	1-1/4"	1/4"
008CU0200PL	2"	1-3/4"	1-1/4"	1/4"

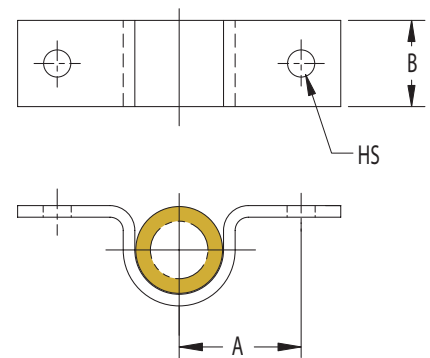

PIPE FIXINGS YOOK

Yook U-type Hanger

- Size Range: 1" through 4"
- Surface Finish: Electro-zinc plated
- Use in place of U-hook
- Use with Model #43, size #16 x 2" L Wood Drive Screws
- For 2-1/2" thru 4" pipe sizes, use two drive screws per leg

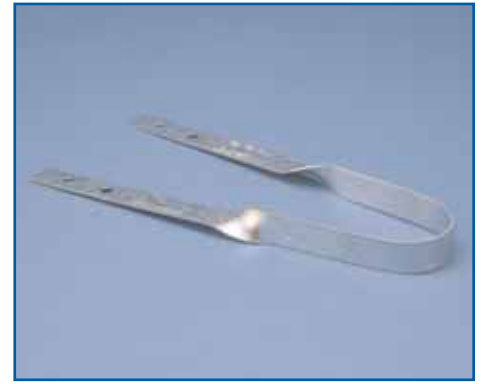

Part Number	Nominal Pipe Size	W	H	Max. Rec. Load (lbs)
1351204EG	1" & 1-1/4"	2-13/16"	4-13/16"	250
1351206EG	1" & 1-1/4"	2-13/16"	6-7/8"	250
1351208EG	1" & 1-1/4"	2-13/16"	8-7/8"	250
1351210EG	1" & 1-1/4"	2-13/16"	10-7/8"	250
1351212EG	1" & 1-1/4"	2-13/16"	12-7/8"	250
1352004EG	1-1/2" & 2"	3-1/2"	4-13/16"	250
1352006EG	1-1/2" & 2"	3-1/2"	6-7/8"	250
1352008EG	1-1/2" & 2"	3-1/2"	8-7/8"	250
1352010EG	1-1/2" & 2"	3-1/2"	10-7/8"	250
1352012EG	1-1/2" & 2"	3-1/2"	12-7/8"	250
1353008EG	2-1/2" & 3"	4-13/16"	8-7/8"	320
1353010EG	2-1/2" & 3"	4-13/16"	10-7/8"	320
1353012EG	2-1/2" & 3"	4-13/16"	12-7/8"	320
1354008EG	3-1/2" & 4"	5-15/16"	8-7/8"	560
1354010EG	3-1/2" & 4"	5-15/16"	10-7/8"	560
1354012EG	3-1/2" & 4"	5-15/16"	12-7/8"	560

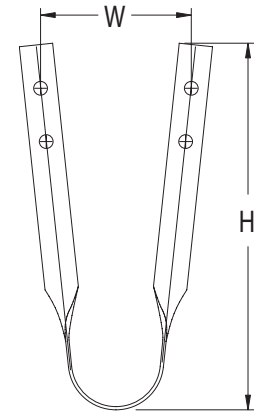

PIPE FIXINGS DWV

DWV Insulated Hanger

- Size Range: 1-1/2" through 4"
- Surface Finish: Electro-zinc plated with Vinyl Coat
- Use in place of U-hook
- When hanging steel or cast iron pipe, install with 1-1/2", #10 wood screws
- For 2-1/2" thru 4" pipe sizes, use two drive screws per leg



Part Number	Nominal Pipe Size	W	H
1390150EG	1-1/2"	1"	14-3/4"
1390200EG	2"	1"	15-1/4"
1390250EG	2-1/2"	1"	15-1/2"
1390300EG	3"	1"	16-3/4"
1390400EG	4"	1"	17-1/2"

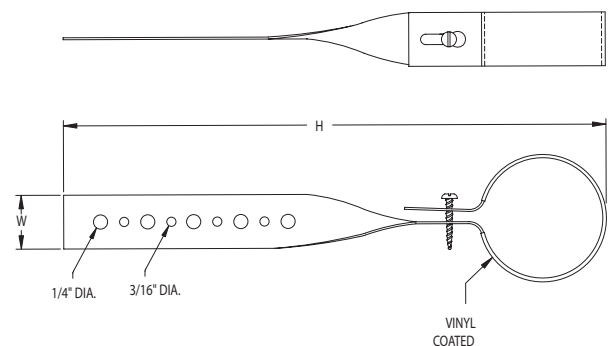

PIPE FIXINGS WH

Wire Pipe Hook PL

- Size Range: 1/2" through 2"
- Surface Finish: Black, Copper-plated, Vinyl-coated



Part Number	Nominal Pipe Size	GA	L
Plain Finish			
WH04050PL	1/2"	10	4"
WH06050PL	1/2"	10	6"
WH04075PL	3/4"	10	4"
WH06075PL	3/4"	10	6"
WH08075PL	3/4"	10	8"
WH06100PL	1"	10	6"
WH06125PL	1-1/4"	10	6"
WH06150PL	1-1/2"	10	6"
WH08200PL	2"	10	8"
WH10200PL	2"	10	10"
Copper-plated Finish			
WH02050CP	1/2"	10	2-1/2"
WH04050CP	1/2"	10	4"
WH06050CP	1/2"	10	6"
WH02075CP	3/4"	10	2-1/2"
WH04075CP	3/4"	10	4"
WH06075CP	3/4"	10	6"
WH08075CP	3/4"	10	8"
WH06100CP	1"	10	6"
Vinyl-coated Finish			
WH04050VC	1/2"	10	4"
WH06050VC	1/2"	10	6"
WH04075VC	3/4"	10	4"
WH06075VC	3/4"	10	6"
WH08075VC	3/4"	10	8"
WH06100VC	1"	10	6"
WH06125VC	1-1/4"	10	6"
WH06150VC	1-1/2"	10	6"
WH08200VC	2"	10	8"



PIPE FIXINGS TPC

Tube and Pipe Clamp

- Size Range: 3/8" through 2-3/8"
- Positions pipe or tube in stud wall applications
- May be used with the CADDY TSGB for an adjustable pipe bracket and clamping system



Part Number	Description
TPC112	Tube and pipe clamp 3/8" thru 1-1/8"
TPC238	Tube and pipe clamp 5/8" thru 2-3/8"
TSGB16112	Kit -- includes TPC112 and 16" TSGB (adjustable screw gun bracket)
TSGB24112	Kit -- includes TPC112 and 24" TSGB (adjustable screw gun bracket)



PIPE FIXINGS CADDY® SUPERKLIP

Tube and Pipe Clamp

- Size Range: 3/8" through 2"
- Pushing the tube into the clamp closes and locks the pipe clamp
- Fasten with either wood screw, dual threaded screw with or without collar, nail with collar or 1/4" threaded rod
- Age resistant, UV resistant, suitable for outdoor applications
- Color: White



Part Number	Nominal Pipe Size		A	B	C	Max. Rec. Load (lbs)
	IP	CT				
389001	-	3/8"	7/16" – 9/16"	9/16"	1-3/16"	40
389002	-	1/2"	9/16" – 11/16"	9/16"	1-3/16"	45
389003	3/8"	5/8"	11/16" – 3/4"	5/8"	1-13/32"	50
389004	1/2"	-	3/4" – 7/8"	5/8"	1-9/16"	50
389005	-	3/4"	7/8" – 31/32"	21/32"	1-5/8"	55
389006	3/4"	-	31/32" – 1-3/32"	11/16"	1-3/4"	60
389007	-	1"	1-3/32" – 1-7/32"	11/16"	1-15/16"	65
389008	1"	1-1/4"	1-7/32" – 1-13/32"	11/16"	2-1/8"	75
389011	1-1/4"	1-1/2"	1-9/16" – 1-23/32"	3/4"	2-1/2"	85
389012	1-1/2"	-	1-27/32" – 2"	3/4"	2-7/8"	100
389013	-	2"	2" – 2-3/16"	25/32"	3-3/32"	105
389014	2"	-	2-5/16" – 2-1/2"	13/16"	3-15/32"	120

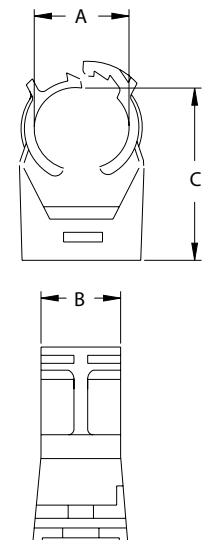

PIPE FIXINGS SMS8

Self-tapping Screw

- Suitable for screw gun use
- #8 x 1/2" long



Part Number	Description
SMS8	#8 x 1/2" Self-tapping screw



PIPE FIXINGS SGB

Preset Screw Gun Bracket for Between Studs

- Preset for studs 16" or 24" on center
- Can mount multiple pipe or tubes
- Notched and marked for easy bending and installation
- Requires only a screw gun to install
- Can be mounted to face or inside of stud
- Can be preassembled by the contractor to allow for greater productivity at the job site



Part Number	Stud Spacing
SGB16A	16" OC
SGB24A	24" OC

PIPE FIXINGS TSGB

Adjustable Screw Gun Bracket for Between Studs

- Can mount multiple pipe or tubes
- Notched and marked for easy bending and installation
- Requires only a screw gun to install
- Can be mounted to face or inside of stud
- Adjustable for non-standard stud spacing
- Unique, one-piece break apart design
- Interlocking tab prevents accidental disassembly



Part Number	Stud Spacing
TSGB16	16" OC
TSGB24	24" OC



PIPE FIXINGS 150M

Standard U-bolt

- Size Range: 1/2" through 18"
- Surface Finish: Black, Electro-zinc plated
- Pipe support for general piping applications
- Comes with two nuts installed on each end of U-bolt



Part Number	Nominal Pipe Size	A	RS	Max. Rec. Load (lbs)
Plain Finish				
150M0050PL	1/2 "	3-1/2 "	1/4 "	435
150M0075PL	3/4 "	3-9/16 "	1/4 "	435
150M0100PL	1 "	3-11/16 "	1/4 "	435
150M0125PL	1-1/4 "	4-1/8 "	3/8 "	1090
150M0150PL	1-1/2 "	4-5/16 "	3/8 "	1090
150M0200PL	2 "	4-13/16 "	3/8 "	1090
150M0250PL	2-1/2 "	5-3/4 "	1/2 "	2020
150M0300PL	3 "	6-5/16 "	1/2 "	2020
150M0400PL	4 "	7-5/16 "	1/2 "	2020
150M0500PL	5 "	8-5/16 "	1/2 "	2020
150M0600PL	6 "	10-1/8 "	5/8 "	3230
150M0800PL	8 "	12-1/8 "	5/8 "	3230
150M1000PL	10 "	14-9/16 "	3/4 "	4830
150M1200PL	12 "	16-15/16 "	7/8 "	6730
150M1400PL	14 "	18-3/16 "	7/8 "	6730
150M1600PL	16 "	20-5/16 "	7/8 "	6730
150M1800PL	18 "	22-11/16 "	1 "	8850
Electro-zinc Plated Finish				
150M0050EG	1/2 "	3-1/2 "	1/4 "	435
150M0075EG	3/4 "	3-9/16 "	1/4 "	435
150M0100EG	1 "	3-11/16 "	1/4 "	435
150M0125EG	1-1/4 "	4-1/8 "	3/8 "	1090
150M0150EG	1-1/2 "	4-5/16 "	3/8 "	1090
150M0200EG	2 "	4-13/16 "	3/8 "	1090
150M0250EG	2-1/2 "	5-3/4 "	1/2 "	2020
150M0300EG	3 "	6-5/16 "	1/2 "	2020
150M0400EG	4 "	7-5/16 "	1/2 "	2020
150M0500EG	5 "	8-5/16 "	1/2 "	2020
150M0600EG	6 "	10-1/8 "	5/8 "	3230
150M0800EG	8 "	12-1/8 "	5/8 "	3230
150M1000EG	10 "	14-9/16 "	3/4 "	4830
150M1200EG	12 "	16-15/16 "	7/8 "	6730
150M1400EG	14 "	18-3/16 "	7/8 "	6730
150M1600EG	16 "	20-5/16 "	7/8 "	6730
150M1800EG	18 "	22-11/16 "	1 "	8850

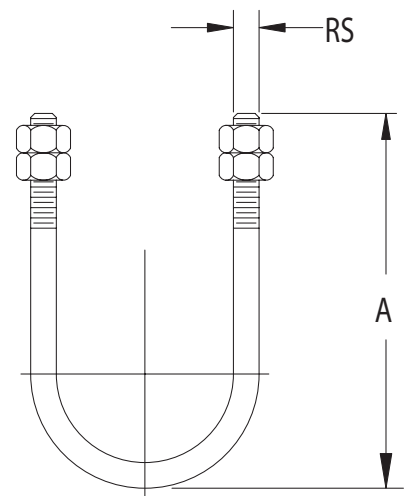

STRUCTURAL ATTACHMENT M-SERIES

Finger Close Pipe Clamp

- Size Range: 1/2" through 2"
- Surface Finish: CADDY® COAT
- May be used for either vertical or horizontal installations
- Mounting hole for 1/4" bolt or rod



Part Number	Nominal Pipe Size	Max. Rec. Load (lbs)
812M	1/2" - 3/4"	100
16M	1"	100
20M	1-1/4"	100
24M	1-1/2"	100
32M	2"	100



STRUCTURAL ATTACHMENT MCP-SERIES

Finger Close Pipe Copper-tubing Clamp

- Size Range: 1/2" through 2"
- Surface Finish: Copper-colored coating (for identification purposes only)
- May be used for either vertical or horizontal installations
- Mounting hole for 1/4" bolt or rod

Part Number	Nominal Pipe Size	Max. Rec. Load (lbs)
812MCP	1/2" - 3/4"	100
16MCP	1"	100
20MCP	1-1/4"	100
24MCP	1-1/2"	100
32MCP	2"	100

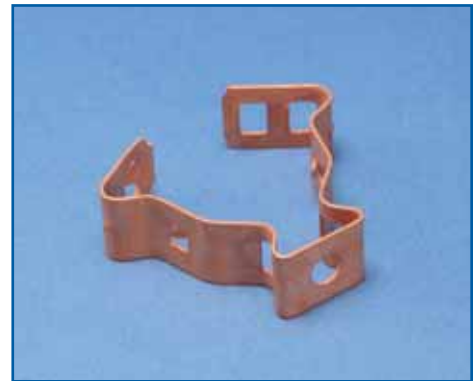

STRUCTURAL ATTACHMENT M-SERIES

Hammer-on, Finger Close Pipe Clamp

- Size Range: 1/2" through 2"
- Surface Finish: CADDY® COAT
- Used to support pipe from beam flanges 1/8" to 3/4" thick
- Pipe/tube clip pivots a full 360°



Part Number	Flange Thickness	Nominal Pipe Size	Max. Rec. Load (lbs)
812M24	1/8" - 1/4"	1/2" - 3/4"	75
812M58	5/16" - 1/2"	1/2"	75
812M912	9/16" - 3/4"	1/2"	75
16M24	1/8" - 1/4"	1"	75
16M58	5/16" - 1/2"	1"	75
16M912	9/16" - 3/4"	1"	75
20M24	1/8" - 1/4"	1-1/4"	75
20M58	5/16" - 1/2"	1-1/4"	75
20M912	9/16" - 3/4"	1-1/4"	75
24M24	1/8" - 1/4"	1-1/2"	75
24M58	5/16" - 1/2"	1-1/2"	75
24M912	9/16" - 3/4"	1-1/2"	75
32M24	1/8" - 1/4"	2"	75
32M58	5/16" - 1/2"	2"	75
32M912	9/16" - 3/4"	2"	75

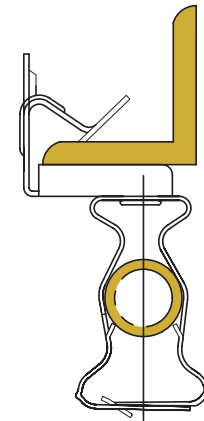

STRUCTURAL ATTACHMENT MCP-SERIES

Hammer-on, Finger Close Copper Tubing Clamp

- Size Range: 1/2" through 2"
- Surface Finish: Copper colored coating (for identification purposes only)
- Used to support copper tubing from beam flanges 1/8" to 3/4" thick
- Pipe/tube clip pivots a full 360°



Part Number	Flange Thickness	Nominal Pipe Size	Max. Rec. Load (lbs)
6MCP24	1/8" - 1/4"	1/2"	75
6MCP58	5/16" - 1/2"	1/2"	75
6MCP912	9/16" - 3/4"	1/2"	75
812MCP24	1/8" - 1/4"	1/2" - 3/4"	75
812MCP58	5/16" - 1/2"	1/2"	75
812MCP912	9/16" - 3/4"	1/2"	75
16MCP24	1/8" - 1/4"	1"	75
16MCP58	5/16" - 1/2"	1"	75
16MCP912	9/16" - 3/4"	1"	75
20MCP24	1/8" - 1/4"	1-1/4"	75
20MCP58	5/16" - 1/2"	1-1/4"	75
20MCP912	9/16" - 3/4"	1-1/4"	75
24MCP24	1/8" - 1/4"	1-1/2"	75
24MCP58	5/16" - 1/2"	1-1/2"	75
24MCP912	9/16" - 3/4"	1-1/2"	75
32MCP24	1/8" - 1/4"	2"	75
32MCP58	5/16" - 1/2"	2"	75
32MCP912	9/16" - 3/4"	2"	75

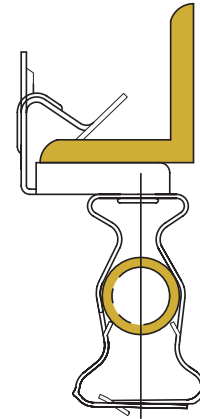

STRUCTURAL ATTACHMENT CD-SERIES

One-piece Pipe Clip

- Size Range: 1/2" through 2"
- Surface Finish: Electro-zinc plated
- May be used for either vertical or horizontal installations

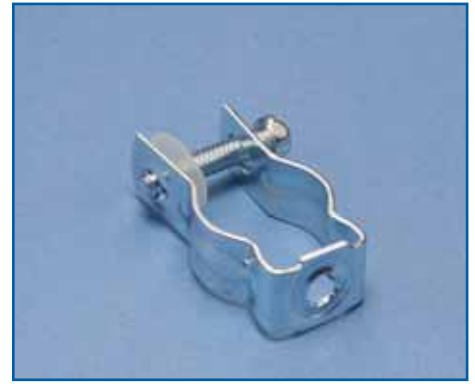

Part Number	Flange Thickness	Bolt Size	Max. Rec. Load (lbs)
CD0B	1/2 "	1/4 "	250
CD1B	3/4 "	1/4 "	250
CD2B	1 "	1/4 "	250
CD3B	1-1/4 "	1/4 "	250
CD4B	1-1/2 "	5/16 "	350
CD5B	2 "	5/16 "	350
CD6B	2-1/2 "	5/16 "	350
CD7B	3 "	5/16 "	350
CD8B	3-1/2 "	5/16 "	350
CD9B	4 "	5/16 "	350
CD0B37	1/2 "	3/8 "	250
CD1B37	3/4 "	3/8 "	250
CD2B37	1 "	3/8 "	250
CD3B37	1-1/4 "	3/8 "	250
CD4B37	1-1/2 "	3/8 "	350
CD5B37	2 "	3/8 "	350

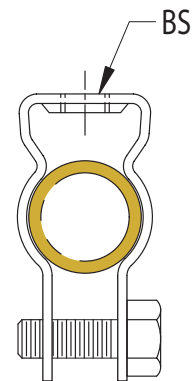

STRUCTURAL ATTACHMENT CDCP-SERIES

One-piece Pipe Clip for Copper Tubing

- Size Range: 1/2" through 2"
- Surface Finish: Copper colored coating (for identification purposes only)
- May be used for either vertical or horizontal installations



Part Number	Flange Thickness	Bolt Size	Max. Rec. Load (lbs)
CD0BCP	1/2"	1/4"	250
CD1BCP	3/4"	1/4"	250
CD2BCP	1"	1/4"	250
CD2.5BCP	1-1/4"	1/4"	250
CD3BCP	1-1/2"	1/4"	350
CD5BCP	2"	5/16"	350
CD0B37CP	1/2"	3/8"	250
CD1B37CP	3/4"	3/8"	250
CD2B37CP	1"	3/8"	250
CD2.53B37CP	1-1/4"	3/8"	250
CD3B37CP	1-1/2"	3/8"	350
CD5B37CP	2"	3/8"	350

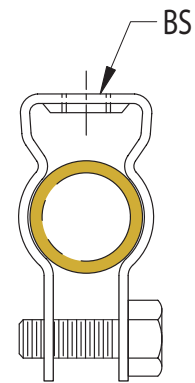

PIPE FIXINGS 801

Standard Pipe Stay

- Size Range: 1/2" through 2" (Copper)
3/8" through 2" (Iron)
- Surface Finish: Black epoxy coat
- Used for water, heat or gas lines
- Sized for copper or iron pipe sizes

Part Number	Nominal Iron Pipe Size	Nominal Copper Pipe Size	A
801037050EP	3/8"	1/2"	2-1/4"
801050075EP	1/2"	3/4"	2-1/4"
801075100EP	3/4"	1"	2-9/16"
801100125EP	1"	1-1/4"	2-9/16"
801125150EP	1-1/4"	1-1/2"	4-1/4"
801150000EP	1-1/2"	-	4-1/4"
801000200EP	-	2"	4-3/8"
801200000EP	2"	-	4-3/8"

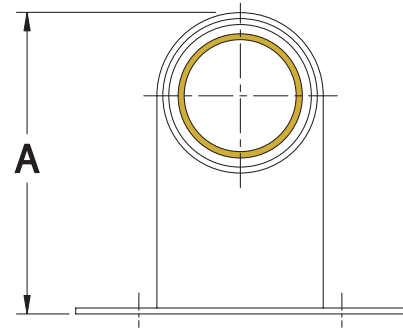
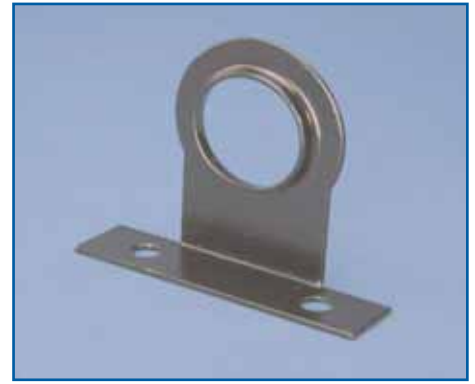

PIPE FIXINGS 800

Extended Pipe Stay

- Size Range: 1/2" through 1-1/4" (Copper)
3/8" through 1" (Iron)
- Surface Finish: Black epoxy coat
- Used for water, heat or gas lines
- Sized for copper or iron pipe sizes

Part Number	Nominal Iron Pipe Size	Nominal Copper Pipe Size	A
800037050EP	3/8"	1/2"	3-5/16"
800050075EP	1/2"	3/4"	3-5/16"
800075100EP	3/4"	1"	3-11/16"
800100125EP	1"	1-1/4"	3-13/16"

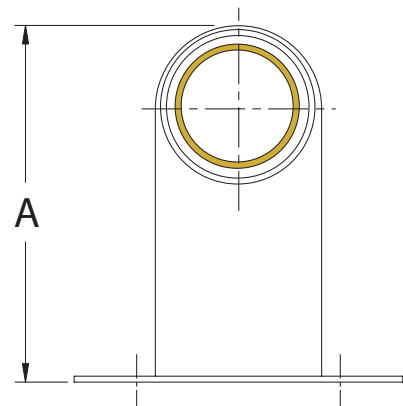

PIPE FIXINGS 802

Double Pipe Stay

- Size Range: 1/2" through 1" (Copper)
3/8" through 3/4" (Iron)
- Surface Finish: Black epoxy coat
- Used for water, heat or gas lines
- Sized for copper or iron pipe sizes



Part Number	Nominal Iron Pipe Size	Nominal Copper Pipe Size	A
802037050EP	3/8"	1/2"	2-3/16"
802050075EP	1/2"	3/4"	2-3/16"
802075100EP	3/4"	1"	2-9/16"

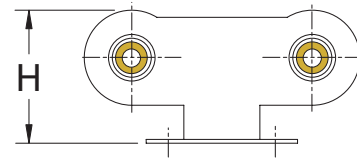

PIPE FIXINGS EPS

One-hole Strap for Thin-walled Conduit

- Size Range: 1/2" thru 2" EMT conduit
- Surface Finish: Electro-zinc plated

Part Number	Nominal Pipe Size	A	HS
EPS0050EG	1/2"	3/4"	9/32"
EPS0075EG	3/4"	7/8"	9/32"
EPS0100EG	1"	1"	9/32"
EPS0125EG	1-1/4"	1-1/4"	9/32"
EPS0150EG	1-1/2"	1"	11/32"
EPS0200EG	2"	1-1/4"	11/32"

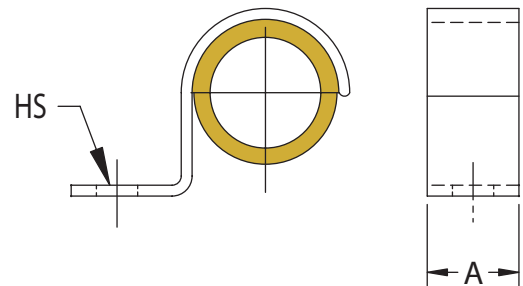

CADDY® SPEED LINK

NEW



Page 62

CADDY® SPEED LINK

NEW



Page 63

CADDY® SPEED LINK LD

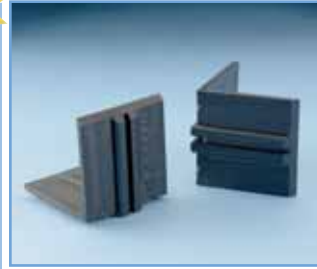

Page 64

SLADCP



Page 64

SLADS



Page 64

SLWC



Page 64

SLWPT



Page 64

SLEB

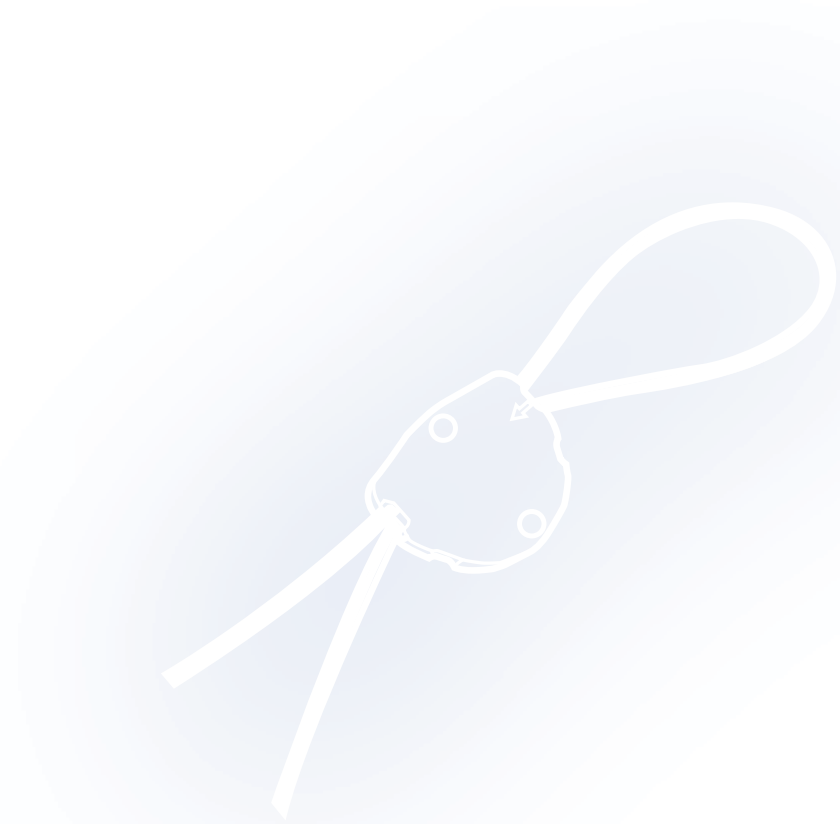

CADDY® SPEED LINK



Hanging System

- Size Range: 0.079" and 0.118" wire rope
- Surface Finish: Stainless Steel/Galvanized Steel
- Universal support system recommended for the suspension of ductwork, piping or equipment
- Tested and found to be acceptable alternative to the duct hanger systems prescribed in the SMACNASM HVAC Duct Construction Standards (HVAC-DCS), 2nd Edition, Chapter 4, Tables 4-1, 4-1M, 4-2 and 4-2M
- Meets the fire rating requirements for DIN 4102-2 for 30 minutes at 30% of rated load
- 5:1 Safety Factor



Part Number	Wire Rope Dimensions		Qty. per Box	Max. Working Load (lbs)
	Wire Rope Size	Length		
SLD2L1	0.079 in (2 mm)	3.3 ft (1 m)	100	100 lbs (45 kg)
SLD2L2	0.079 in (2 mm)	6.6 ft (2 m)	100	100 lbs (45 kg)
SLD2L3	0.079 in (2 mm)	9.9 ft (3 m)	100	100 lbs (45 kg)
SLD2L5	0.079 in (2 mm)	16.4 ft (5 m)	50	100 lbs (45 kg)
SLD2L10	0.079 in (2 mm)	32.8 (10 m)	25	100 lbs (45 kg)
SLD3L1	0.118 in (3 mm)	3.3 ft (1 m)	100	200 lbs (90 kg)
SLD3L2	0.118 in (3 mm)	6.6 ft (2 m)	100	200 lbs (90 kg)
SLD3L3	0.118 in (3 mm)	9.9 ft (3 m)	50	200 lbs (90 kg)
SLD3L5	0.118 in (3 mm)	16.4 ft (5 m)	50	200 lbs (90 kg)
SLD3L10	0.118 in (3 mm)	32.8 (10 m)	25	200 lbs (90 kg)
Individually Packaged				
SLD2L1BP	0.079 in (2 mm)	3.3 ft (1 m)	100	100 lbs (45 kg)
SLD2L2BP	0.079 in (2 mm)	6.6 ft (2 m)	100	100 lbs (45 kg)
SLD2L3BP	0.079 in (2 mm)	9.9 ft (3 m)	100	100 lbs (45 kg)
SLD3L2BP	0.118 in (3 mm)	6.6 ft (2 m)	100	200 lbs (90 kg)
SLD3L3BP	0.118 in (3 mm)	9.9 ft (3 m)	50	200 lbs (90 kg)
Stainless Steel				
SLD3L2SS	0.118 in (3 mm)	6.6 ft (2 m)	100	200 lbs (90 kg)
SLD3L3SS	0.118 in (3 mm)	9.9 ft (3 m)	50	200 lbs (90 kg)

Features

- Eliminates threaded rod and associated hardware
- Reduces installation time
- Quickly installs as a stand-alone hanging system without drilling into the building structure
- Increases installation versatility
- Allows for easy adjustments of supported objects during and after installation with a unique locking device

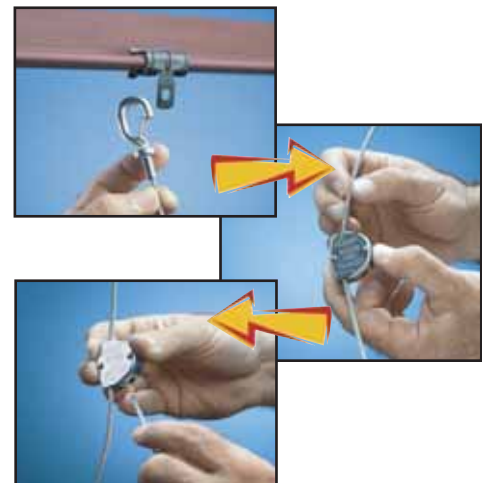

The ERICO website contains an aid to determine the length of the CADDY SPEED LINK necessary for a specific application.



CADDY® SPEED LINK LD

Light Duty Hanging System

- Size Range: 0.059" wire rope
- Surface Finish: Stainless Steel/Galvanized Steel
- Universal support system recommended for the suspension of ductwork, piping or equipment
- Meets the fire rating requirements for DIN 4102-2 for 30 minutes at 30% of rated load
- 5:1 Safety Factor



Part Number	Wire Rope Dimensions		Qty. per Box	Max. Working Load (lbs)
	Wire Rope Size	Length		
SLD15L2	0.059 in (1.5 mm)	6.6 ft (2 m)	20	44 lbs (20 kg)
SLD15L5	0.059 in (1.5 mm)	16.4 ft (5 m)	20	44 lbs (20 kg)
SLD15L10	0.059 in (1.5 mm)	32.8 ft (10 m)	20	44 lbs (20 kg)
Stainless Steel				
SLD15L2S	0.059 in (1.5 mm)	6.6 ft (2 m)	2	44 lbs (20 kg)
SLD15L5S	0.059 in (1.5 mm)	16.4 ft (5 m)	2	44 lbs (20 kg)
SLD15L10S	0.059 in (1.5 mm)	32.8 ft (10 m)	2	44 lbs (20 kg)

Features

- Cost-effective alternative to jack chain, threaded rod and associated hardware
- Safe working load of 20 kg (44 lb)
- Adjustable after installation
- Works with a variety of CADDY® Fasteners

The ERICO website contains an aid to determine the length of the CADDY SPEED LINK necessary for a specific application.



CADDY® SPEED LINK TOOLS AND ACCESSORIES

P/N	Description	Qty. per Box
SLADCP	Air Duct Corner Protector	10
SLADS	Air Duct Support Attachment	100
SLWC	Wire Cutter	1
SLWPT	Wire Insulation Protection Tube	82 ft
SL1214	Cable Clip .468-.562 MC/AC Cable	100
SL1518	Cable Clip .500-.718 MC/AC Cable	100
SLLC250*	Lighting Clip, 1/4"	200
SLEB250	Eye Bolt M6; 1/4"; 1-1/4" long	100
SLEB375	Eye Bolt M8; 3/8"; 1-1/2" long	100
SLEBWS	Eye Bolt for Wood; H6, 60 mm long	100
VAFT	Installation tool for VF & AF assemblies	1

* 22,5 kg ultimate static load limit



VAFT



SLADCP



SLADS



SLWC



SLWPT



SLEB250/SLEB375/SLEBWS



CADDY® PYRAMID



NEW

Page 66

CADDY® PYRAMID 25



NEW

Page 67

CADDY® PYRAMID 50



NEW

Page 68

**CADDY® PYRAMID 150
CADDY® PYRAMID 300
CADDY® PYRAMID 600**



CADDY® PYRAMID 25

- Tested for outdoor use
- Small – 4" x 5" footprint
- Innovative designs won't damage roof membranes



Part Number	Fig. No.	Description	Max. Rec. Load (lbs)
PPRPS25H4	1	3-5/8" High Rooftop Pipe Support	25
PPRPS25H6	2	5-5/8" High Rooftop Pipe Support	25



Features

- Lightweight – Less than 1/3 lb.
- Protective – Sled design distributes the load evenly and protects the roof membrane
- Durable – UV-Rated
- Capable – Handles up to three 1/2" or two 3/4" or 1" pipes/conduit
- Easy to Install – No tools or fasteners needed
- Available in both 3-5/8 in. high and 5-5/8 in. high models

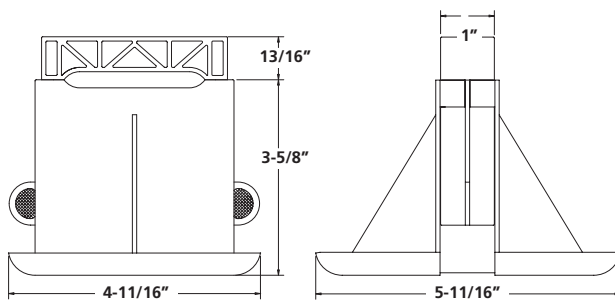

Fig. 1

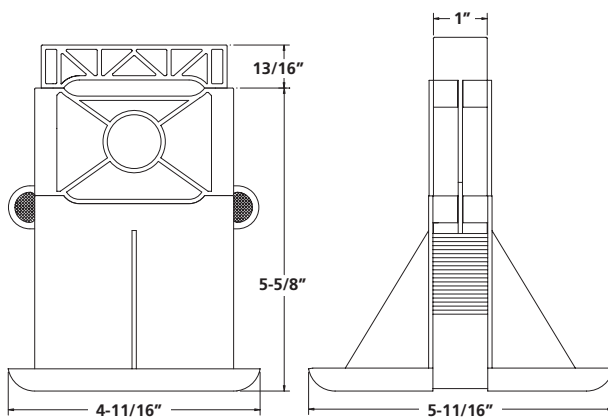

Fig. 2



CADDY® PYRAMID 50

- Surface Finish: Electro-zinc plated, CADDY® COAT Silver
- Eliminates need to field-fabricate rooftop pipe supports
- Large footprints of foam bases distribute loads over wider area
- Tested for outdoor use
- Innovative designs won't damage roof membranes
- The RPS50AHSV is a support for pipes and equipment in plenum areas below raised floors
- 14 gauge steel top accepts standard strut fittings



Part Number	Fig. No.	L	W	H	Max. Rec. Load (lbs)
RPS50AHSV	3	10-3/8"	3-5/16"	2-5/16"	50
RPS50H4EG	4	10-3/8"	4"	4"	50
RPS50H6EG	5	10-3/8"	5"	6"	50

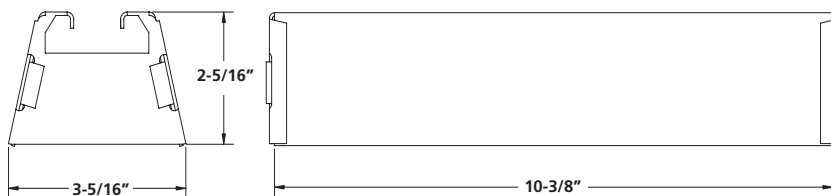

Fig. 3 CADDY COAT Silver

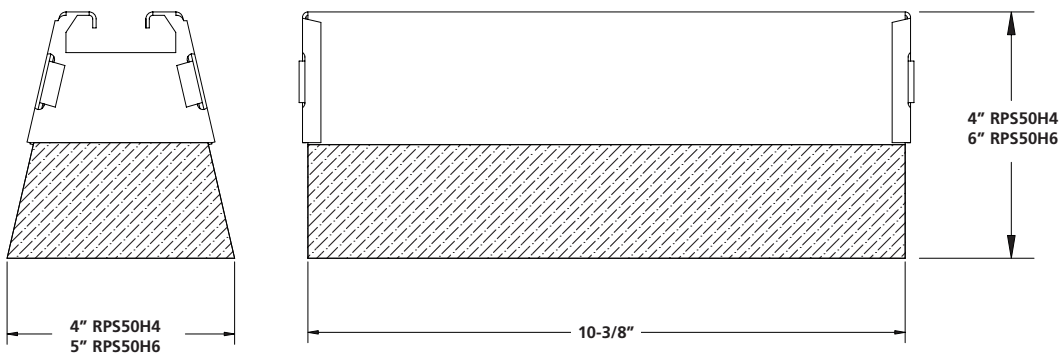

Fig. 4 & 5 Electro-zinc plated

CADDY® PYRAMID 150 CADDY® PYRAMID 300 CADDY® PYRAMID 600



- Surface Finish: Electro-zinc plated
- Tested for outdoor use
- Each base includes a total of six (6) 3/8"-16 threaded inserts to facilitate attachment of threaded hardware
- Eliminates need to field-fabricate rooftop pipe supports
- Large footprints of bases distribute loads over wider area
- Innovative designs won't damage roof membranes
- Available as an assembly with and without CADDY® ERISTRUT channel attached for use as a pipe or equipment support
- May also be used with the P10, P11 and P12 post bases



Part Number	Fig. No.	L	W	H	With Strut	Max. Rec. Load (lbs)
RPS150T1	6	16"	12"	3-3/16"	-	150
RPS150T2	7	16"	12"	4"	X	150
RPS300T1	6	16"	12"	3-3/16"	-	300
RPS300T2	7	16"	12"	4"	X	300
RPS600T2	8	32"	12"	X	600	
RPSCSEG	Not shown	-	-	-	-	600

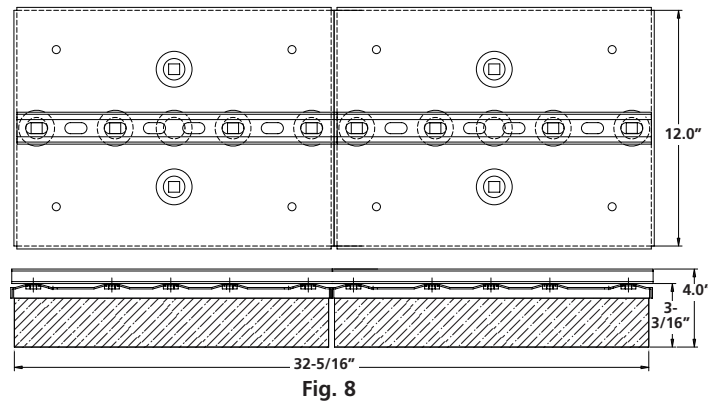
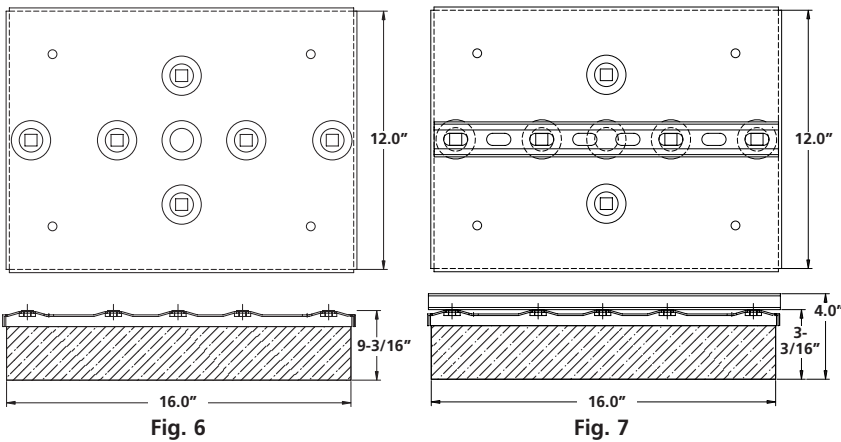



Page 70

EG



Page 70

CP



Page 71

CU



Page 71

MSR



Page 72

MSS

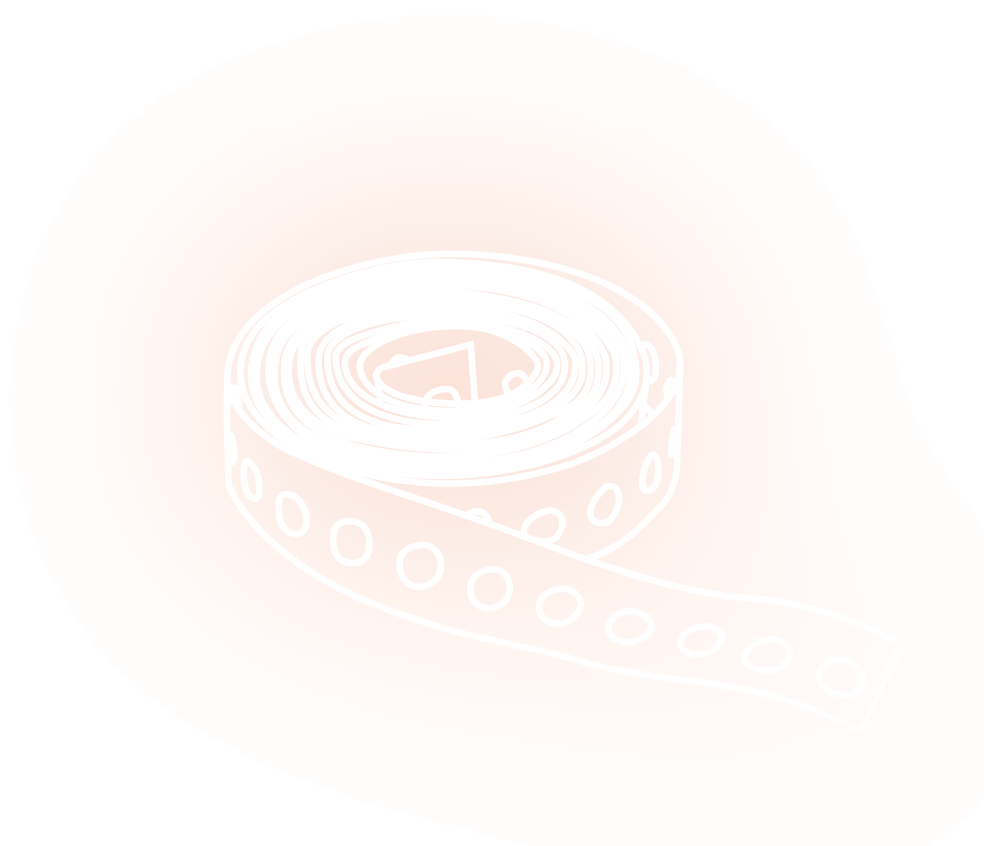

PIPE FIXINGS 009

Perforated Hanger Strap EG

- Size Range: 3/4" x 10' L
- Surface Finish: Electro-zinc plated
- Light duty, residential pipe support
- Follow fastener manufacturer's recommended shear and pull-out strength guidelines when fastening to the structure



Part Number	Strap Gauge	L	Max. Rec. Load (lbs)
0097524EG	24	10' - 0"	10

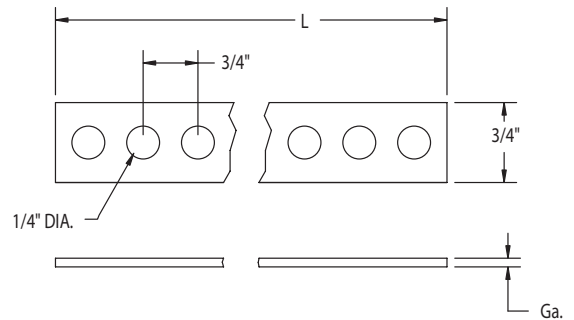

PIPE FIXINGS 009

Perforated Hanger Strap CP

- Size Range: 3/4" x 10' L
- Surface Finish: Copper-colored coating (for identification purposes only)
- Light duty, residential pipe support
- Follow fastener manufacturer's recommended shear and pull-out strength guidelines when fastening to the structure



Part Number	Strap Gauge	L	Max. Rec. Load (lbs)
0097524CP	24	10' - 0"	10

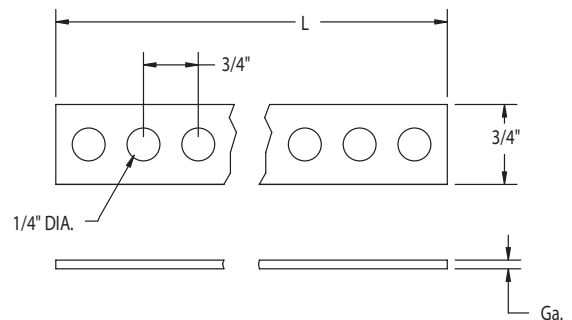

PIPE FIXINGS 009

Perforated Hanger Strap CU

- Size Range: 3/4" x 10' L
- Surface Finish: Solid Copper
- Light duty, residential pipe support
- Follow fastener manufacturer's recommended shear and pull-out strength guidelines when fastening to the structure



Part Number	Strap Gauge	L	Max. Rec. Load (lbs)
0097524CU	24	10' - 0"	10

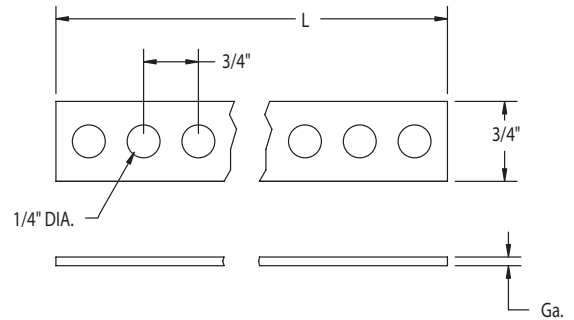

STRUCTURAL ATTACHMENTS MSR

Hammer-On Strap Hanger Clip

- Size Range: 1/8" – 3/4" Flange Thickness
- Surface Finish: Electro-zinc plated, CADDY® COAT
- Supports pipe or duct from flange with banding or strapping
- Note: Pre-measure length of strap, hammer clip onto flange, then trapeze pipe or duct. Accepts strap up to 1-1/4" wide



Part Number	Flange Thickness	Max. Rec. Load (lbs)
MSR24	1/8" – 1/4"	200
MSR58	5/16" – 1/2"	200
MSR912	9/16" – 3/4"	200

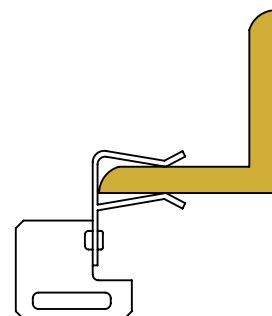

STRUCTURAL ATTACHMENTS MSS

Hammer-On Strap Hanger Clip

- Size Range: 1/8" – 3/4" Flange Thickness
- Surface Finish: Electro-zinc plated, CADDY® COAT
- Supports pipe or duct from flange with banding or strapping

Note: Pre-measure length of strap, hammer clip on to flange, then trapeze pipe or duct. Accepts strap up to 1-1/4" wide



Part Number	Flange Thickness	Max. Rec. Load (lbs)
MSS24	1/8" – 1/4"	200
MSS58	5/16" – 1/2"	200
MSS912	9/16" – 3/4"	200

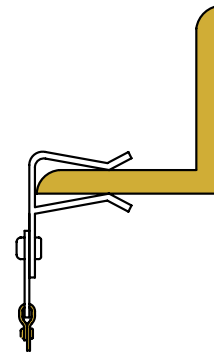



NEW



Page 74

RIGD



Page 75

OD



Page 76

PCC



Page 77

TCC



Page 78

COPC



Page 78

EMTC



NEW

Page 79

TSM



NEW

Page 79

TSMI

NEW



Page 80

SCH

NEW



Page 81

SK

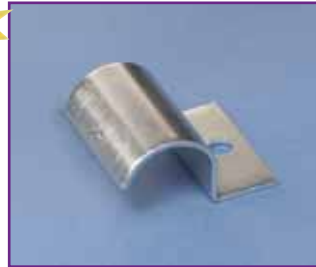

Page 82

STR



Page 82

STR2



Page 83

UNIV



Page 83

VS-20

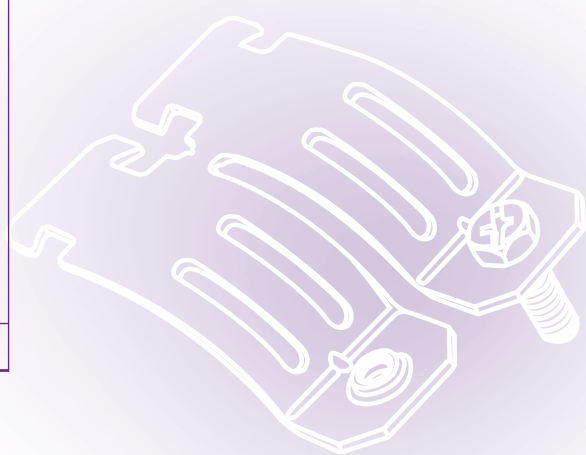

STRUT PIPE CLAMPS RIGD

Heavy Duty Strut Clamps

- Size Range: 3/8" thru 8"
- Surface Finish: Electro-zinc plated
- One piece break apart design (1/2" thru 4" pipe size) includes captive combo head machine screw and built in nut (thread impression)



Part Number	Nominal Pipe Size	OD	Strap GA	Max. Rec. Load (lbs)
RIGD0037EG	3/8"	.675"	17 GA	400
RIGD0050EG	1/2"	.840"	14 GA	400
RIGD0075EG	3/4"	1.050"	14 GA	600
RIGD0100EG	1"	1.315"	14 GA	600
RIGD0125EG	1-1/4"	1.660"	14 GA	600
RIGD0150EG	1-1/2"	1.900"	12 GA	800
RIGD0200EG	2"	2.375"	12 GA	800
RIGD0250EG	2-1/2"	2.875"	12 GA	800
RIGD0300EG	3"	3.500"	12 GA	800
RIGD0350EG	3-1/2"	4.000"	11 GA	1000
RIGD0400EG	4"	4.500"	11 GA	1000
RIGD0500EG	5"	5.563"	12 GA	1000
RIGD0600EG	6"	6.625"	10 GA	1000
RIGD0800EG	8"	8.625"	10 GA	1000

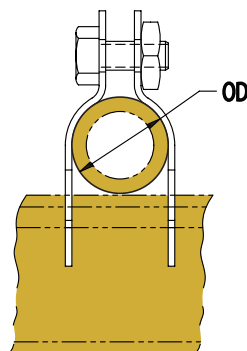
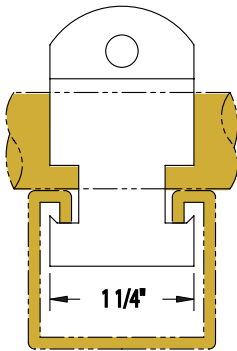

STRUT PIPE CLAMPS OD

Four piece Strut Clamps for Tubing

- Size Range: 1/4" thru 8-5/8"
- Surface Finish: Electro-zinc plated
- Other sizes available upon request
- Four piece design includes hex head machine screw and square nut



Part Number	OD (in)	Strap GA	Max. Rec. Load (lbs)
OD0025EG	1/4	17 GA	400
OD0037EG	3/8	17 GA	400
OD0050EG	1/2	17 GA	400
OD0062EG	5/8	17 GA	400
OD0075EG	3/4	17 GA	400
OD0087EG	7/8	17 GA	400
OD0100EG	1	15 GA	600
OD0112EG	1-1/8	15 GA	600
OD0125EG	1-1/4	15 GA	600
OD0137EG	1-3/8	15 GA	600
OD0150EG	1-1/2	15 GA	600
OD0162EG	1-5/8	15 GA	600
OD0175EG	1-3/4	13 GA	800
OD0187EG	1-7/8	13 GA	800
OD0200EG	2	13 GA	800
OD0212EG	2-1/8	13 GA	800
OD0225EG	2-1/4	13 GA	800
OD0237EG	2-3/8	13 GA	800
OD0250EG	2-1/2	13 GA	800
OD0262EG	2-5/8	13 GA	800
OD0275EG	2 3/4	13 GA	800
OD0287EG	2-7/8	13 GA	800
OD0300EG	3	13 GA	800
OD0312EG	3-1/8	13 GA	800
OD0325EG	3-1/4	13 GA	800
OD0337EG	3-3/8	13 GA	800
OD0350EG	3-1/2	13 GA	800
OD0362EG	3-5/8	12 GA	1000
OD0375EG	3-3/4	12 GA	1000
OD0387EG	3-7/8	12 GA	1000
OD0400EG	4	12 GA	1000
OD0412EG	4-1/8	12 GA	1000
OD0425EG	4-1/4	12 GA	1000
OD0437EG	4-3/8	12 GA	1000
OD0450EG	4-1/2	12 GA	1000
OD0462EG	4-5/8	12 GA	1000
OD0475EG	4-3/4	12 GA	1000
OD0487EG	4-7/8	12 GA	1000
OD0500EG	5	12 GA	1000
OD0512EG	5-1/8	12 GA	1000

Part Number	OD (in)	Strap GA	Max. Rec. Load (lbs)
OD0525EG	5-1/4	12 GA	1000
OD0537EG	5-3/8	12 GA	1000
OD0550EG	5-1/2	12 GA	1000
OD0562EG	5-5/8	10 GA	1000
OD0575EG	5-3/4	10 GA	1000
OD0587EG	5-7/8	10 GA	1000
OD0600EG	6	10 GA	1000
OD0612EG	6-1/8	10 GA	1000
OD0625EG	6-1/4	10 GA	1000
OD0637EG	6-3/8	10 GA	1000
OD0650EG	6-1/2	10 GA	1000
OD0662EG	6-5/8	10 GA	1000
OD0675EG	6-3/4	10 GA	1000
OD0687EG	6-7/8	10 GA	1000
OD0700EG	7	10 GA	1000
OD0712EG	7-1/8	10 GA	1000
OD0725EG	7-1/4	10 GA	1000
OD0737EG	7-3/8	10 GA	1000
OD0750EG	7-1/2	10 GA	1000
OD0762EG	7-5/8	10 GA	1000
OD0775EG	7-3/4	10 GA	1000
OD0787EG	7-7/8	10 GA	1000
OD0800EG	8	10 GA	1000
OD0812EG	8-1/8	10 GA	1000
OD0825EG	8-1/4	10 GA	1000
OD0837EG	8-3/8	10 GA	1000
OD0850EG	8-1/2	10 GA	1000
OD0862EG	8-5/8	10 GA	1000

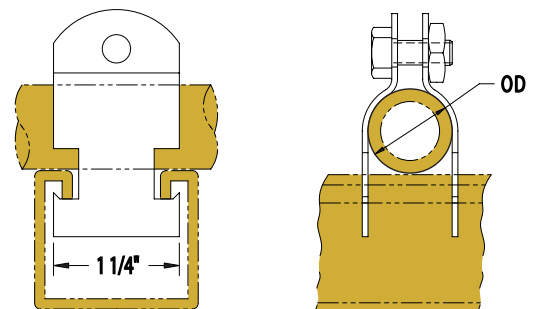

CADDY® CUSHION CLAMP PCC

Pipe Cushion Clamps

- Size Range: 1/4" thru 6"
- Surface Finish: Yellow di-chromate
- Ideal for multiple runs while absorbing shock and vibration, reducing unwanted noise and preventing galvanic corrosion
- Fits any standard 1-5/8" wide strut channel
- Interlock edges and channel locator legs help ensure that the cushion remains in place



Part Number	Nominal Pipe Size	ID	A	B
PCC0025EG	1/4"	.54"	.98"	1.34"
PCC0037EG	3/8"	.67"	1.13"	1.54"
PCC0050EG	1/2"	.84"	1.29"	1.82"
PCC0075EG	3/4"	1.05"	1.57"	2.08"
PCC0100EG	1"	1.31"	1.76"	2.34"
PCC0125EG	1-1/4"	1.66"	2.17"	2.73"
PCC0150EG	1-1/2"	1.90"	2.35"	2.86"
PCC0200EG	2"	2.37"	2.82"	3.67"
PCC0250EG	2-1/2"	2.87"	3.32"	4.17"
PCC0300EG	3"	3.50"	3.95"	4.79"
PCC0350EG	3-1/2"	4.00"	4.45"	5.42"
PCC0400EG	4"	4.50"	4.95"	5.92"
PCC0500EG	5"	5.56"	6.01"	6.92"
PCC0600EG	6"	6.62"	7.07"	8.23"

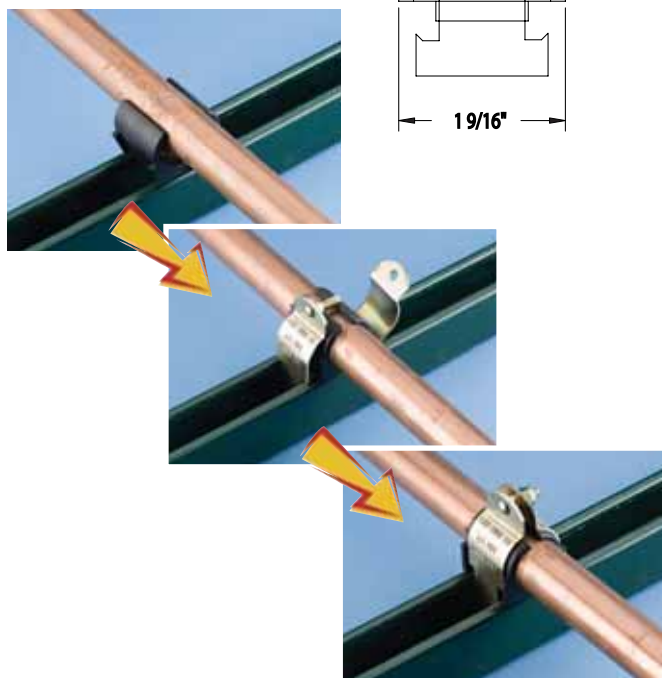
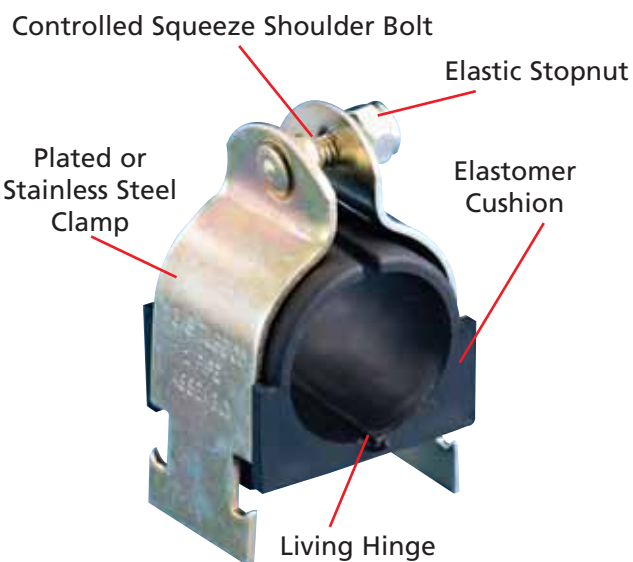
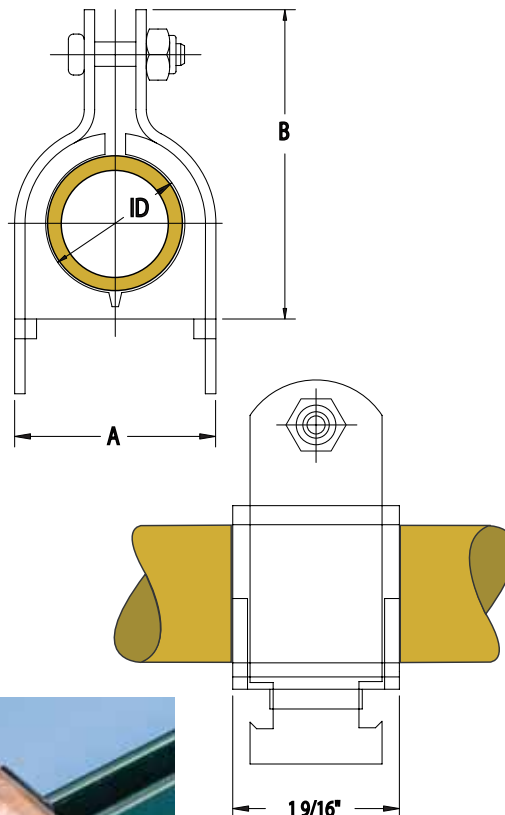

CADDY® CUSHION CLAMP TCC

Tubing Cushion Clamps

- Size Range: 1/4" thru 6"
- Surface Finish: Yellow di-chromate
- Ideal for multiple runs while absorbing shock and vibration, reducing unwanted noise and preventing galvanic corrosion
- Fits any standard 1-5/8" wide strut channel
- Interlock edges and channel locator legs help ensure that the cushion remains in place

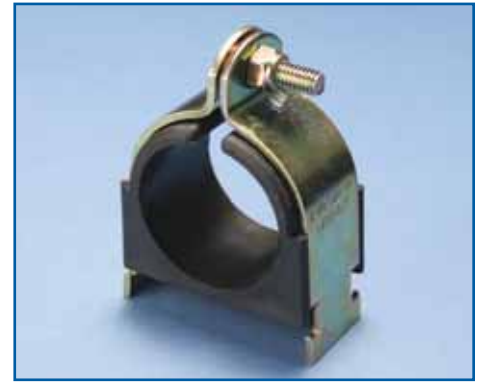

Part Number	Nominal Pipe Size		ID	A	B
	Copper & Steel Tubing	Copper Water Pipe (Nominal)			
TCC0025CP	1/4"	-	.25"	.62"	.98"
TCC0037CP	3/8"	1/4"	.37"	.82"	1.13"
TCC0050CP	1/2"	3/8"	.50"	.94"	1.34"
TCC0062CP	5/8"	1/2"	.62"	1.06"	1.54"
TCC0075CP	3/4"	5/8"	.75"	1.20"	1.68"
TCC0087CP	7/8"	3/4"	.87"	1.31"	1.82"
TCC0100CP	1"	7/8"	1.00"	1.44"	1.95"
TCC0112CP	1-1/8"	1"	1.12"	1.57"	2.08"
TCC0125CP	1-1/4"	1-1/8"	1.25"	1.70"	2.21"
TCC0137CP	1-3/8"	1-1/4"	1.37"	1.82"	2.34"
TCC0150CP	1-1/2"	1-3/8"	1.50"	1.95"	2.47"
TCC0162CP	1-5/8"	1-1/2"	1.62"	2.07"	2.60"
TCC0175CP	1-3/4"	-	1.75"	2.20"	2.73"
TCC0187CP	1-7/8"	-	1.87"	2.32"	2.86"
TCC0200CP	2"	-	2.00"	2.45"	3.04"
TCC0212CP	2-1/8"	2"	2.12"	2.57"	3.23"
TCC0250CP	2-1/2"	-	2.50"	2.94"	3.79"
TCC0262CP	2-5/8"	2-1/2"	2.62"	3.07"	3.92"
TCC0300CP	3"	-	3.00"	3.57"	4.29"
TCC0312CP	3-1/8"	3"	3.12"	3.57"	4.42"
TCC0331CP	3-5/16"	-	3.31"	3.96"	4.75"
TCC0362CP	3-5/8"	-	3.62"	4.20"	5.11"
TCC0412CP	4-1/8"	4"	4.12"	4.57"	5.54"
TCC0431CP	4-5/16"	-	4.34"	4.96"	5.84"
TCC0512CP	5-1/8"	5"	5.12"	5.57"	6.54"
TCC0612CP	6-1/8"	6"	6.12"	6.57"	7.54"

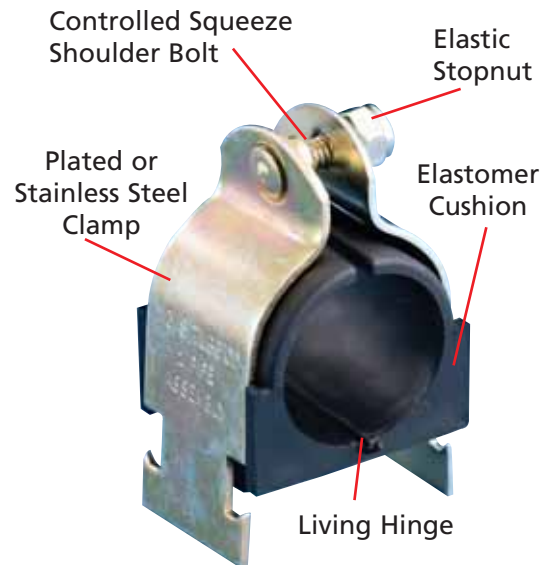
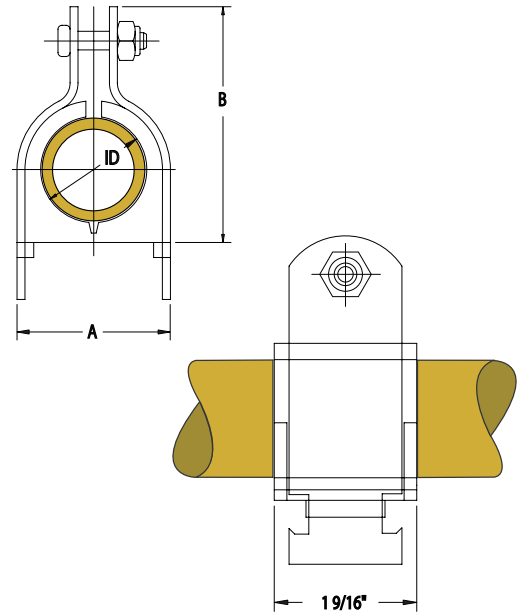

STRUT PIPE CLAMPS COPC

One piece Strut Clamps for Copper Tubing

- Size Range: 1/4" thru 6"
- Surface Finish: Copper-colored coating (for identification purposes only)
- One piece break apart design (1/2" thru 4" pipe size) includes captive combo head machine screw and built in nut (thread impression)



Part Number	Nominal Pipe Size	OD	Max. Rec. Load (lbs)
COPC0025CP	1/4"	3/8"	400
COPC0037CP	3/8"	1/2"	400
COPC0050CP	1/2"	5/8"	400
COPC0075CP	3/4"	7/8"	400
COPC0100CP	1"	1-1/8"	600
COPC0125CP	1-1/4"	1-3/8"	600
COPC0150CP	1-1/2"	1-5/8"	600
COPC0200CP	2"	2-1/8"	800
COPC0250CP	2-1/2"	2-5/8"	800
COPC0300CP	3"	3-1/8"	800
COPC0350CP	3-1/2"	3-5/8"	1000
COPC0400CP	4"	4-1/8"	1000
COPC0500CP	5"	5-1/8"	1000
COPC0600CP	6"	6-1/8"	1000

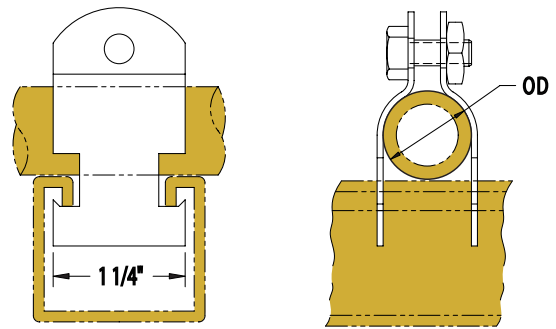

STRUT PIPE CLAMPS EMTC

Four piece Strut Clamps for EMT Conduit

- Size Range: 1/2" thru 2" EMT conduit
- Surface Finish: Electro-zinc plated
- Four piece design includes slotted hex head machine screw and square nut



Part Number	Nominal Pipe Size	Max. Rec. Load (lbs)
EMTC0050EG	1/2"	400
EMTC0075EG	3/4"	600
EMTC0100EG	1"	600
EMTC0125EG	1-1/4"	600
EMTC0150EG	1-1/2"	800
EMTC0200EG	2"	800

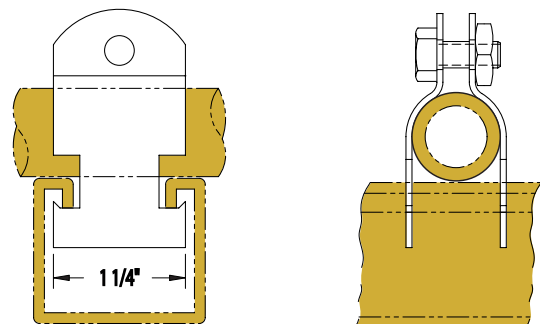

PIPE FIXINGS TSM

TSM Non-metallic Tubing Channel Clip

- Size Range: 1/4" thru 1-1/2" CT sizes
- Use for installation of refrigeration, A/C tubing and PEX piping in horizontal and vertical channels
- Requires no tools for installation
- Fits any standard 1-5/8" wide strut channel

Part Number	Nominal CT Size	PEX Piping	CPVC Drain Pipe
TSM0037	1/4"	1/4"	-
TSM0050	3/8"	3/8"	-
TSM0062	1/2"	1/2"	-
TSM0075	5/8"	5/8"	-
TSM0087	3/4"	3/4"	1/2"
TSM0112	1"	1"	3/4"
TSM0137	1-1/4"	1-1/4"	1"
TSM0162	1-1/2"	1-1/2"	-



PIPE FIXINGS TSMI

TSMI Non-metallic Tubing Channel Clip for Insulated Lines

- Size Range: 1/4" thru 1-1/2" CT sizes
- Use for installation of refrigeration, A/C tubing and PEX piping in horizontal and vertical channels
- Requires no tools for installation
- Fits any standard 1-5/8" wide strut channel
- Allows installation of copper tubing together with insulation of either 3/8" (9 mm) or 1/2" (13 mm) thickness

Part Number	Nominal CT Size	PEX Piping	CPVC Drain Pipe
TSMI0037	1/4"	1/4"	-
TSMI0050	3/8"	3/8"	-
TSMI0062	1/2"	1/2"	-
TSMI0075	5/8"	5/8"	-
TSMI0087	3/4"	3/4"	1/2"
TSMI0112	1"	1"	3/4"
TSMI0137	1-1/4"	1-1/4"	1"
TSMI0162	1-1/2"	1-1/2"	-



STRUT PIPE CLAMPS SCH

One-piece Strut Clips for MC/AC Cable and EMT Conduit

- Size Range: 1/2" thru 4"
- Surface Finish: Electro-zinc plated
- One-piece installation – no screws or bolts to drop
- Requires only a screwdriver or nutdriver for installation
- Fits any standard 1-5/8" wide strut channel



Part Number	Fig. No.	EMT	RIGID	Cable OD Range	Max. Rec. Load (lbs)
SCH8	1	1/2"	-	-	200
SCH12	1	3/4"	1/2"	-	200
SCH16	1	1"	3/4"	-	200
SCH20	1	1-1/4"	1"	-	200
SCH6B	2	3/8" MC/AC	-	.10" - .63"	200
SCH8B	2	1/2"	-	.34" - .71"	200
SCH12B	2	3/4"	1/2"	.57" - .92"	200
SCH16B	2	1"	3/4"	.72" - 1.16"	200
SCH20B	2	1-1/4"	1"	1.00" - 1.51"	200
SCH24B	2	1-1/2"	1-1/4"	1.25" - 1.74"	350
SCH32B	2	2"	1-1/2"	1.74" - 2.20"	350
SCH40B	3	-	2"	2.00" - 2.38"	350
SCH48B	3	2-1/2"	2-1/2"	2.38" - 2.88"	350
SCH56B	3	3"	3"	2.72" - 3.50"	350
SCH64B	3	3-1/2"	3-1/2"	3.25" - 4.00"	350
SCH72B	3	4"	4"	3.85" - 4.50"	350

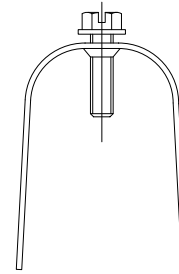

Fig.1

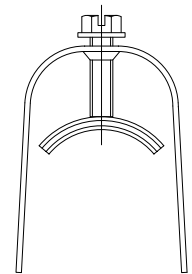

Fig.2

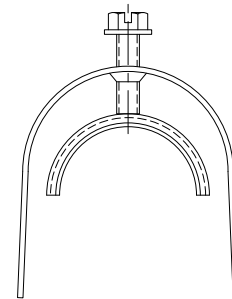

Fig.3



STRUT PIPE CLAMPS SK

One-piece Universal Strut Clips

- Size Range: 1/2" thru 4"
- Surface Finish Electro-zinc plated
- One-piece break apart design includes captive combo head machine screw and built-in nut (thread impression)
- Fits any standard 1-5/8" wide strut channel
- One size fits both EMT conduit and Rigid pipe sizes

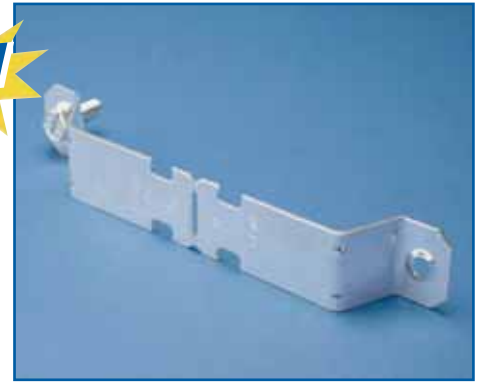

Part Number	Fig. No.	EMT RIGID	Max. Rec. Load (lbs)
SK85I	1	1/2"	200
SK125I	1	3/4"	200
SK165I	1	1"	200
SK205I	1	1-1/4"	200
SK245I	1	1-1/2"	200
SK325I	1	2"	200
SK405I	2	2-1/2"	350
SK485I	2	3"	350
SK565I	2	3-1/2"	350
SK645I	2	4"	350

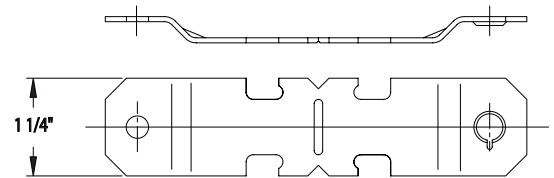

Fig.1

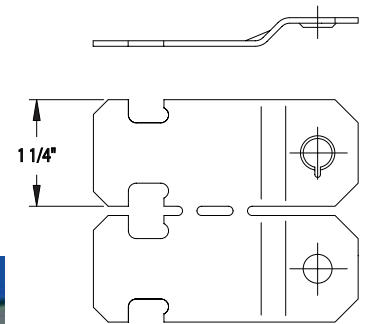

Fig.2



PIPE FIXINGS STR

One-hole Pipe Strap for Strut

- Size Range: 1/4" thru 1"
- Surface Finish: Electro-zinc plated
- Fits any standard 1-5/8" wide strut channel

Part Number	Nominal Pipe Size	A	HS
STR0025EG	1/4"	11/16"	9/32"
STR0037EG	3/8"	3/4"	9/32"
STR0050EG	1/2"	13/16"	9/32"
STR0062EG	5/8"	7/8"	9/32"
STR0075EG	3/4"	15/16"	9/32"
STR0087EG	7/8"	1"	9/32"
STR0100EG	1"	1-1/8"	9/32"

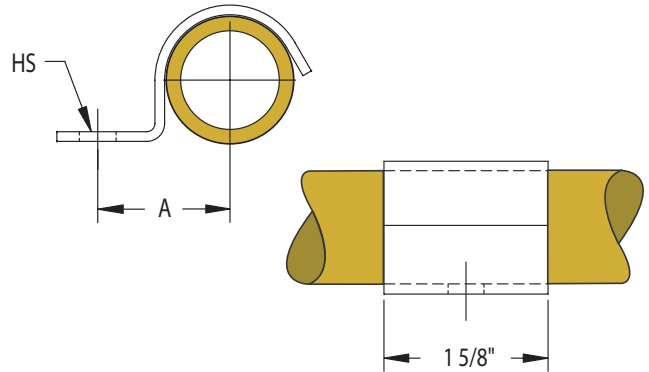
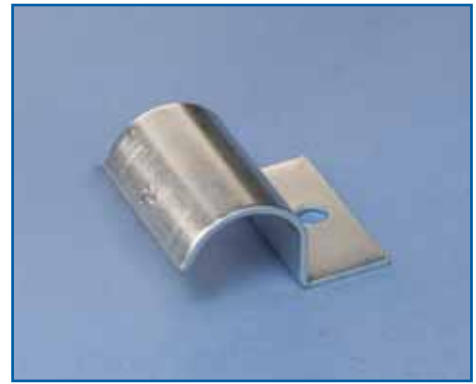

PIPE FIXINGS STR2

Two-hole Pipe Strap for Strut

- Size Range: 1/2" thru 6"
- Surface Finish: Electro-zinc plated
- Fits any standard 1-5/8" wide strut channel

Part Number	Nominal Pipe Size	A	HS	Max. Rec. Load (lbs)
STR20050EG	1/2"	1-1/16"	9/32"	600
STR20075EG	3/4"	1-3/16"	9/32"	600
STR20100EG	1"	1-3/8"	9/32"	600
STR20125EG	1-1/4"	1-7/16"	9/32"	600
STR20150EG	1-1/2"	1-5/8"	9/32"	600
STR20200EG	2"	2-3/16"	7/16"	1200
STR20250EG	2-1/2"	2-7/16"	7/16"	1200
STR20300EG	3"	2-13/16"	7/16"	1200
STR20350EG	3-1/2"	3-1/4"	7/16"	1200
STR20400EG	4"	3-5/16"	7/16"	1500
STR20500EG	5"	3-7/8"	7/16"	1500
STR20600EG	6"	4-1/2"	7/16"	1500

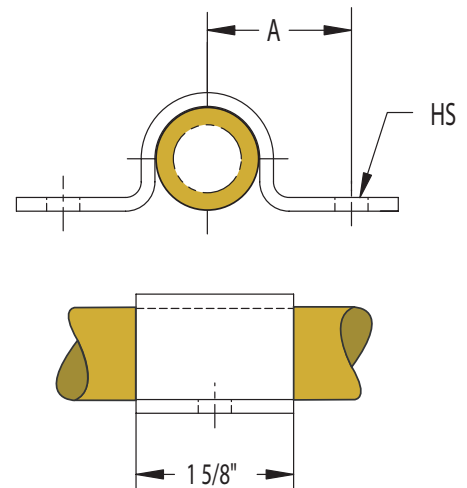
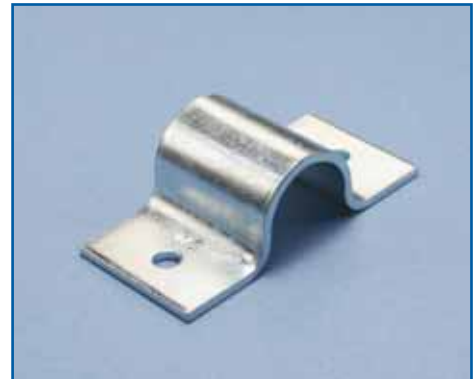

STRUT PIPE CLAMPS UNIV

One-piece Strut Clip for Rigid or EMT Conduit

- Size Range: 1/2" thru 2" Rigid or EMT conduit
- Surface Finish: Electro-zinc plated
- One-piece break apart design includes captive combo head machine screw and built-in nut (thread impression)

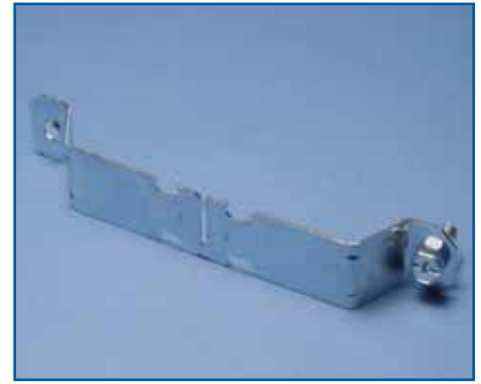

Part Number	Nominal Pipe Size	Max. Rec. Load (lbs)
UNIV0050EG	1/2"	400
UNIV0075EG	3/4"	600
UNIV0100EG	1"	600
UNIV0125EG	1-1/4"	600
UNIV0150EG	1-1/2"	800
UNIV0200EG	2"	800



PIPE FIXINGS VS-20

Vibra-strip Cushion Strip for Strut Clamps

- Isolation material for use with strut clamps
- Inhibits galvanic corrosion
- Dampens sound and vibration
- Service temperature range of -75°F to +375°F
- P/N: VS200000



NEW Products



CPVC PIPE FIXING SO

- Two-hole strap for CPVC pipe
- Support CPVC pipe off of the vertical face of structural or composite wood joists with a minimum of 3/8" web thickness

See page 87



NEW



Page 86

107



Page 86

108



Page 87

109



Page 87

SO



CPVC PIPE FIXINGS 107

One-hole Wrap Around Strap for CPVC Pipe

- Size Range: 3/4" thru 2" CPVC pipe
- Surface Finish: Electro-zinc plated
- Support CPVC pipe horizontally from top or side of beam
- Flared edges protect the CPVC piping

Part Number	Nominal Pipe Size	A	B	Max. Hanger Spacing
1070075EG	3/4"	1-1/4"	2-3/8"	5-1/2'
1070100EG	1"	1-7/16"	2-11/16"	6'
1070125EG	1-1/4"	1-5/8"	3-1/16"	6-1/2'
1070150EG	1-1/2"	1-3/4"	3-5/16"	7'
1070200EG	2"	1-7/8"	3-11/16"	8'

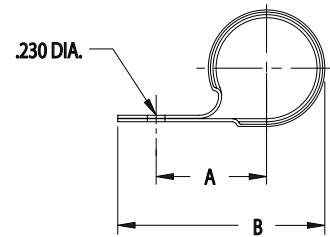
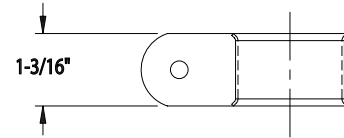

CPVC PIPE FIXINGS 108

Two-hole Strap for CPVC Pipe

- Size Range: 3/4" thru 2" CPVC pipe
- Surface Finish: Electro-zinc plated
- Support CPVC pipe horizontally from top, bottom or side of beam
- Retainer dimples secure hanger to pipe during installation
- Flared edges protect the CPVC piping

Part Number	Nominal Pipe Size	A	B	Max. Hanger Spacing
1080075EG	3/4"	3-1/4"	2-1/4"	5-1/2'
1080100EG	1"	3-1/2"	2-1/2"	6'
1080125EG	1-1/4"	4-1/4"	3-1/4"	6-1/2'
1080150EG	1-1/2"	4-7/16"	3-7/16"	7'
1080200EG	2"	4-15/16"	3-15/16"	8'

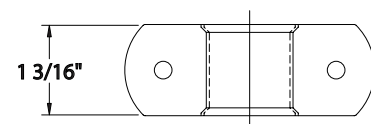
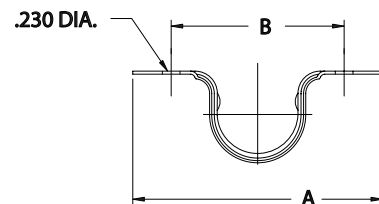

CPVC PIPE FIXINGS 109

Side Mount Strap for CPVC Pipe

- Size Range: 3/4" thru 2" CPVC pipe
- Surface Finish: Electro-zinc plated
- Support CPVC pipe horizontally from top or bottom of beam
- Retainer dimples secure hanger to pipe during installation
- Flared edges protect the CPVC piping



Part Number	Nominal Pipe Size	A	B	Max. Hanger Spacing
1090075EG	3/4"	2-5/16"	1-11/16"	5-1/2'
1090100EG	1"	2-5/8"	1-15/16"	6'
1090125EG	1-1/4"	2-15/16"	2-5/16"	6-1/2'
1090150EG	1-1/2"	3-3/16"	2-1/2"	7'
1090200EG	2"	3-5/8"	3"	8'

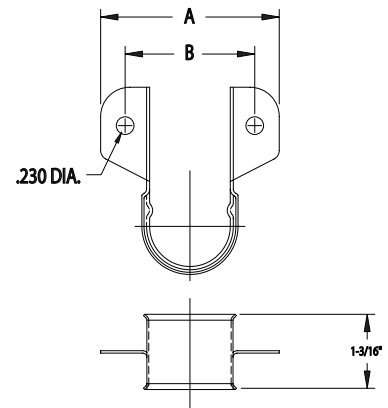

CPVC PIPE FIXING SO

Stand-off Two-hole Strap for CPVC Pipe

- Size Range: 3/4" thru 2" CPVC pipe
- Surface Finish: Electro-zinc plated
- Support CPVC pipe off of the vertical face of structural or composite wood joists with a minimum of 3/8" web thickness
- Flared edges protect the CPVC piping



Part Number	Nominal Pipe Size	A	B	Max. Hanger Spacing
SO12A	3/4"	2-11/16"	3-1/4"	5-1/2'
SO16A	1"	2-15/16"	3-1/4"	6'
SO20A	1-1/4"	3-5/16"	3-1/4"	6-1/2'
SO24A	1-1/2"	3-9/16"	4-1/2"	7'
SO32A	2"	4-1/16"	5"	8'

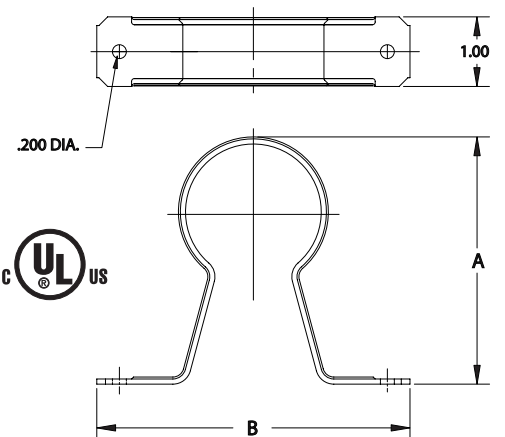

CADDY®

IT'S SIMPLE MATH.

CADDY® Pipe Supports = Job-Site Efficiency.

CADDY® Pipe Hangers and Mechanical Supports:

- + Offer one-stop shopping. CADDY® has a broad line of products for job-site efficiency in HVAC/R, plumbing and fire-protection applications
- + Deliver time savings through innovative designs which reduce installation time
- + Offer creative alternatives to traditional suspension methods – such as the CADDY® SPEED LINK universal support system



1-800-333-0852
www.erico.com

ERICO®





Page 91

280



Page 92

300



Page 93

310



Page 94

255



Page 95

255L



Page 96

BC26



Page 97

200



Page 98

200RS



Page 99

547/548



Page 100

PH



Page 101

PHSW

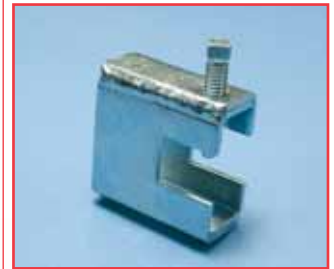

Page 102

BC13



Page 103

BC14

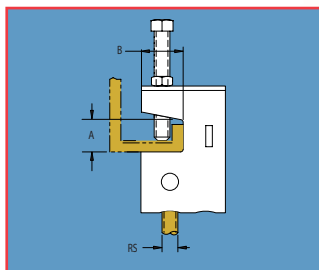

Page 104

BC10

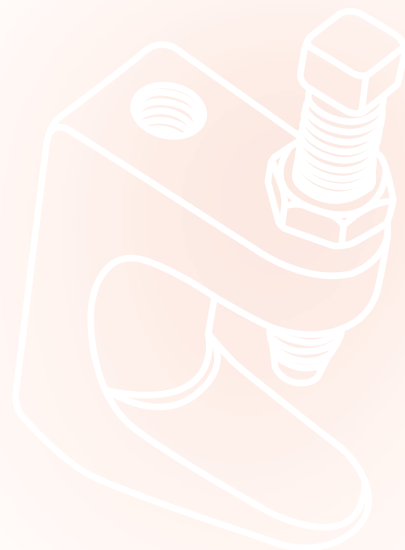



Page 105

BC15



Page 105

BC09



Page 106

315



Page 107

PAR



Page 107

ET



Page 108

RA



Page 109

300C



Page 110

35RS



Page 110

34SL



Page 111

255C

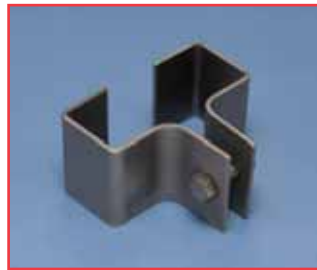

Page 111

356



Page 112

360



Page 113

361



Page 114

363

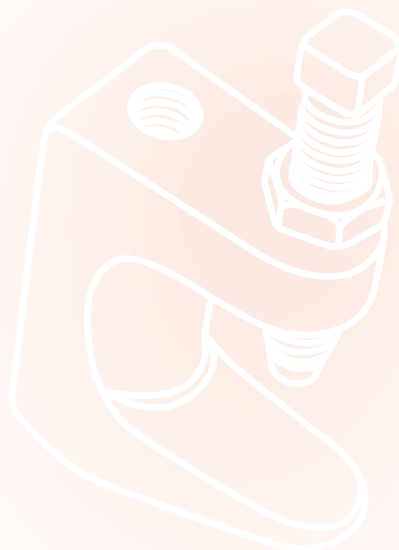

BEAM CLAMP 280

Universal Malleable Iron Beam Clamp

- Size Range: 3/8", 1/2", 5/8" and 3/4" rod sizes
- Surface Finish: Black, Electro-zinc plated
- Structural attachment to top or bottom of metal beams, purlins, channel, or angle iron
- Setscrew made of hardened steel
- For retainer straps see Models 300C and 035RS
- Available with a HD finish by special order
- Conforms with Federal Specification WW-H-171 (Type 23), Manufacturers Standardization Society ANSI/MSS-SP-58 (Type 19 & 23), install in accordance with ANSI/MSS-SP-69
- Setscrew must be tightened and torqued onto the sloped side of the I-beam



Part Number	RS	A	B	Set Screw	Max. Rec. Load (lbs)
Plain Finish					
2800037PL	3/8"	3/4"	7/8"	3/8	500
2800050PL	1/2"	3/4"	7/8"	3/8	950
2800062PL	5/8"	3/4"	7/8"	1/2	950
2800075PL	3/4"	3/4"	1"	1/2	950
Electro-zinc Plated Finish					
2800037EG	3/8"	3/4"	7/8"	3/8	500
2800050EG	1/2"	3/4"	7/8"	3/8	950
2800062EG	5/8"	3/4"	7/8"	1/2	950
2800075EG	3/4"	3/4"	1"	1/2	950

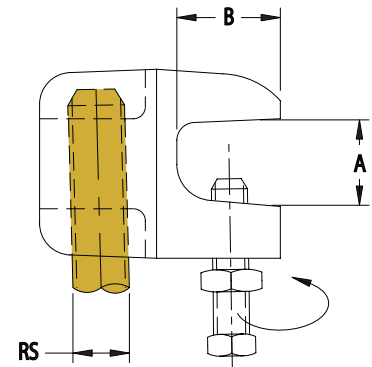

Recommended Torque** (for setscrews):

Setscrew Size	1/4-20	3/8-16	1/2-13	5/8-11	3/4-10
Foot-lbs	4	5	11	21	34
Nm	(5)	(7)	(15)	(28)	(46)

**Recognizing that torque wrenches are generally not used or available on many job sites, the setscrew should be tightened so it contacts the I-beam and then an additional 1/4 to 1/2 turn added.

BEAM CLAMP 300

Universal Ductile Iron Beam Clamp

- Size Range: 3/8", 1/2", 5/8", 3/4" and 7/8" rod sizes
- Surface Finish: Black, Electro-zinc plated
- Structural attachment to top or bottom of metal beams, purlins, channel, or angle iron
- Setscrew made of hardened steel
- For retainer straps see Models 300C and 035RS
- Available with a HD finish by special order
- Conforms with Federal Specification WW-H-171 (Type 23), Manufacturers Standardization Society ANSI/MSS-SP-58 (Type 19 & 23), install in accordance with ANSI/MSS-SP-69
- Setscrew must be tightened and torqued onto the sloped side of the I-beam

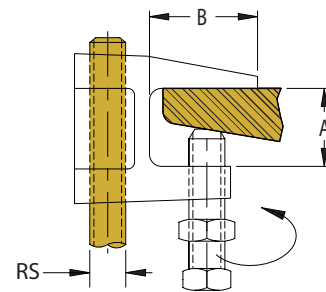

TOP

May be mounted in either position

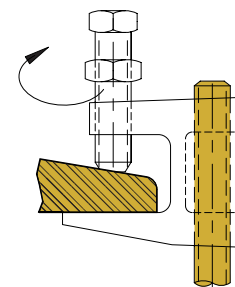

BOTTOM

Part Number	RS	A	B	Set Screw	Max. Rec. Load (lbs)	
					Top	Bottom
Plain Finish						
3000037PL*	3/8	3/4"	1-1/8"	3/8"	500	250
3000050PL*	1/2	3/4"	1-1/8"	7/16"	950	760
3000062PL	5/8	3/4"	1-1/8"	3/8"	950	760
3000075PL	3/4	3/4"	1-1/8"	3/8"	950	760
3000087PL	7/8	3/4"	1-1/8"	3/8"	950	760
Electro-zinc Plated Finish						
3000037EG*	3/8	3/4"	1-1/8"	3/8"	500	250
3000050EG*	1/2	3/4"	1-1/8"	7/16"	950	760
3000062EG	5/8	3/4"	1-1/8"	3/8"	950	760
3000075EG	3/4	3/4"	1-1/8"	3/8"	950	760
3000087EG	7/8	3/4"	1-1/8"	3/8"	950	760

*These sizes are FM approved

Recommended Torque** (for setscrews):

Setscrew Size	1/4-20	3/8-16	7/16-14	1/2-13	5/8-11	3/4-10
Foot-lbs	4	5	8	11	21	34
Nm	(5)	(7)	(11)	(15)	(28)	(46)

**Recognizing that torque wrenches are generally not used or available on many job sites, the setscrew should be tightened so it contacts the I-beam and then an additional 1/4 to 1/2 turn added.



BEAM CLAMP 310

Universal Ductile Iron Large Opening Beam Clamp

- Size Range: 3/8" and 1/2" rod sizes
- Surface Finish: Black, Electro-zinc plated
- Structural attachment to top or bottom of metal beams, purlins, channel, or angle iron
- Setscrew made of hardened steel
- For retainer straps see Models 300C and 035RS
- Available with a HD finish by special order
- Conforms with Federal Specification WW-H-171 (Type 23), Manufacturers Standardization Society ANSI/MSS-SP-58 (Type 19 & 23), install in accordance with ANSI/MSS-SP-69
- Setscrew must be tightened and torqued onto the sloped side of the I-beam



Part Number	RS	A	B	Set Screw	Max. Rec. Load (lbs)	
					Top	Bottom
Plain Finish						
3100037PL	3/8	1-1/4"	1"	3/8"	500	250
3100050PL	1/2	1-1/4"	1"	1/2"	950	760
Electro-zinc Plated Finish						
3100037EG	3/8	1-1/4"	1"	3/8"	500	250
3100050EG	1/2	1-1/4"	1"	1/2"	950	760

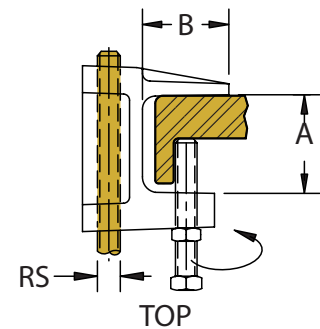

May be mounted in either position

Recommended Torque** (for setscrews):

Setscrew Size	1/4-20	3/8-16	1/2-13	5/8-11	3/4-10
Foot-lbs	4	5	11	21	34
Nm	(5)	(7)	(15)	(28)	(46)

**Recognizing that torque wrenches are generally not used or available on many job sites, the setscrew should be tightened so it contacts the I-beam and then an additional 1/4 to 1/2 turn added.

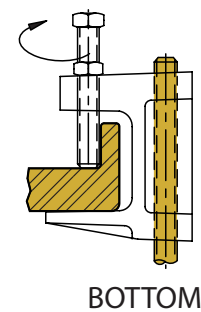

BEAM CLAMP 255

Malleable Iron Beam Clamp, Non-adjustable

- Size Range: 3/8", 1/2" and 5/8" rod sizes
- Surface Finish: Black, Electro-zinc plated
- Structural attachment to top or bottom of metal beams, purlins, channel, or angle iron
- Setscrew made of hardened steel
- For retainer straps see Models 255C
- Conforms with Federal Specification WW-H-171 (Type 23), Manufacturers Standardization Society ANSI/MSS-SP-58 (Type 23), install in accordance with ANSI/MSS-SP-69
- Setscrew must be tightened and torqued onto the sloped side of the I-beam



Part Number	RS	A	B	Set Screw	Max. Pipe Size	Max. Rec. Load (lbs)
Plain Finish						
2550037PL	3/8	3/4"	7/8"	3/8"	2"	400
2550050PL	1/2	3/4"	7/8"	3/8"	3-1/2"	400
2550062PL	5/8	3/4"	1-1/16"	3/8"	5"	400
Electro-zinc Plated Finish						
2550037EG	3/8	3/4"	7/8"	3/8"	2"	400
2550050EG	1/2	3/4"	7/8"	3/8"	3-1/2"	400
2550062EG	5/8	3/4"	1-1/16"	3/8"	5"	400

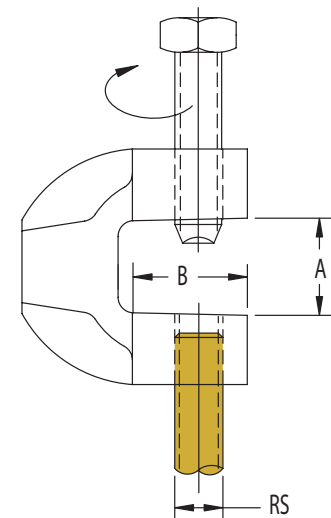

Recommended Torque** (for setscrews):

Setscrew Size	1/4-20	3/8-16	1/2-13	5/8-11	3/4-10
Foot-lbs	4	5	11	21	34
Nm	(5)	(7)	(15)	(28)	(46)

**Recognizing that torque wrenches are generally not used or available on many job sites, the setscrew should be tightened so it contacts the I-beam and then an additional 1/4 to 1/2 turn added.



BEAM CLAMP 255L

Malleable Iron Beam Clamp with Locknut, Non-adjustable

- Size Range: 3/8", 1/2" and 5/8" rod sizes
- Surface Finish: Black, Electro-zinc plated
- Structural attachment to top or bottom of metal beams, purlins, channel, or angle iron
- Setscrew made of hardened steel
- For retainer straps see Models 255C
- Conforms with Federal Specification WW-H-171 (Type 23), Manufacturers Standardization Society ANSI/MSS-SP-58 (Type 23), install in accordance with ANSI/MSS-SP-69
- Setscrew must be tightened and torqued onto the sloped side of the I-beam



Part Number	RS	A	B	Set Screw	Max. Pipe Size	Max. Rec. Load (lbs)
Plain Finish						
255L0037PL	3/8	3/4"	7/8"	3/8	2"	400
255L0050PL	1/2	3/4"	7/8"	3/8	3-1/2"	400
255L0062PL	5/8	3/4"	1-1/16"	3/8	5"	400
Electro-zinc Plated Finish						
255L0037EG	3/8	3/4"	7/8"	3/8	2"	400
255L0050EG	1/2	3/4"	7/8"	3/8	3-1/2"	400
255L0062EG	5/8	3/4"	1-1/16"	3/8	5"	400

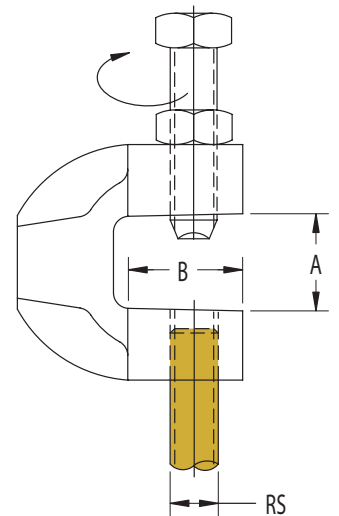

Recommended Torque** (for setscrews):

Setscrew Size	1/4-20	3/8-16	1/2-13	5/8-11	3/4-10
Foot-lbs	4	5	11	21	34
Nm	(5)	(7)	(15)	(28)	(46)

**Recognizing that torque wrenches are generally not used or available on many job sites, the setscrew should be tightened so it contacts the I-beam and then an additional 1/4 to 1/2 turn added.

BEAM CLAMP BC26

Universal Malleable Iron Beam Clamp

- Size Range: 1/4" rod size
- Surface Finish: Electro-zinc plated
- Structural attachment to top or bottom of metal beams, purlins, channel, or angle iron
- Setscrew made of hardened steel
- Includes a 1/4" threaded opening in the back side of body
- Setscrew must be tightened and torqued onto the sloped side of the I-beam



Part Number	RS	A	B	Set Screw	Max. Rec. Load (lbs)	
Electro-zinc Plated Finish					Top	Bottom
BC260025EG	1/4	15/16"	13/16"	1/4	250	100

Recommended Torque** (for setscrews):

Setscrew Size	1/4-20	3/8-16	1/2-13	5/8-11	3/4-10
Foot-lbs	4	5	11	21	34
Nm	(5)	(7)	(15)	(28)	(46)

**Recognizing that torque wrenches are generally not used or available on many job sites, the setscrew should be tightened so it contacts the I-beam and then an additional 1/4 to 1/2 turn added.

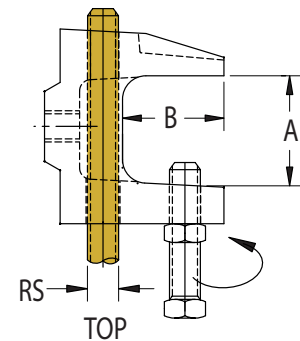

May be mounted in either position

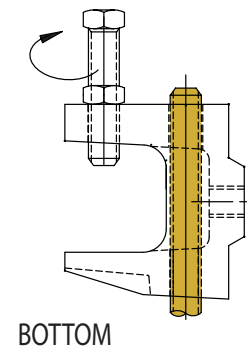

BEAM CLAMP 200

Steel C-clamp, Non-adjustable

- Size Range: 3/8" and 1/2" rod sizes
- Surface Finish: Black, Electro-zinc plated
- Structural attachment to top or bottom of metal beams, purlins, channel, or angle iron
- Setscrew made of hardened steel
- For retainer straps see Models 255 and 255C
- Conforms with Federal Specification WW-H-171 (Type 23), Manufacturers Standardization Society ANSI/MSS-SP-58 (Type 23), install in accordance with ANSI/MSS-SP-69
- Setscrew must be tightened and torqued onto the sloped side of the I-beam



Part Number	RS	A	B	Set Screw	Max. Pipe Size	Max. Rec. Load (lbs)
Plain Finish						
2000037PL	3/8	3/4"	1-1/8"	3/8	3-1/2"	250
2000050PL	1/2	3/4"	1-5/16"	1/2	8"	360
Electro-zinc Plated Finish						
2000037EG	3/8	3/4"	1-1/8"	3/8	3-1/2"	250
2000050EG	1/2	3/4"	1-5/16"	1/2	8"	360

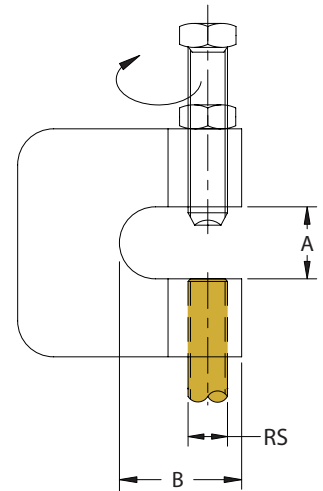

Recommended Torque** (for setscrews):

Setscrew Size	1/4-20	3/8-16	1/2-13	5/8-11	3/4-10
Foot-lbs	4	5	11	21	34
Nm	(5)	(7)	(15)	(28)	(46)

**Recognizing that torque wrenches are generally not used or available on many job sites, the setscrew should be tightened so it contacts the I-beam and then an additional 1/4 to 1/2 turn added.

BEAM CLAMP 200RS

Steel Dual Purpose Strut/Beam C-clamp, Non-adjustable

- Size Range: 3/8" and 1/2" rod sizes
- Surface Finish: Pre-galvanized Steel
- Structural attachment to metal beams and flanges to support strut and/or rod
- Setscrew made of hardened steel
- Setscrew must be tightened and torqued onto the sloped side of the I-beam



Part Number	RS	A	B	Set Screw	Max. Pipe Size	Max. Rec. Load (lbs)*
Pre-galvanized Steel Finish						
200RS375	3/8	5/8"	1-1/2"	3/8	3-1/2"	250
200RS500	1/2	5/8"	1-1/2"	1/2	8"	360

***NOTE:** Load rating is per fastener with a 3X safety factor. Actual installation must be evaluated to determine load on the individual fastener.

Recommended Torque** (for setscrews):

Setscrew Size	1/4-20	3/8-16	1/2-13	5/8-11	3/4-10
Foot-lbs	4	5	11	21	34
Nm	(5)	(7)	(15)	(28)	(46)

**Recognizing that torque wrenches are generally not used or available on many job sites, the setscrew should be tightened so it contacts the I-beam and then an additional 1/4 to 1/2 turn added.

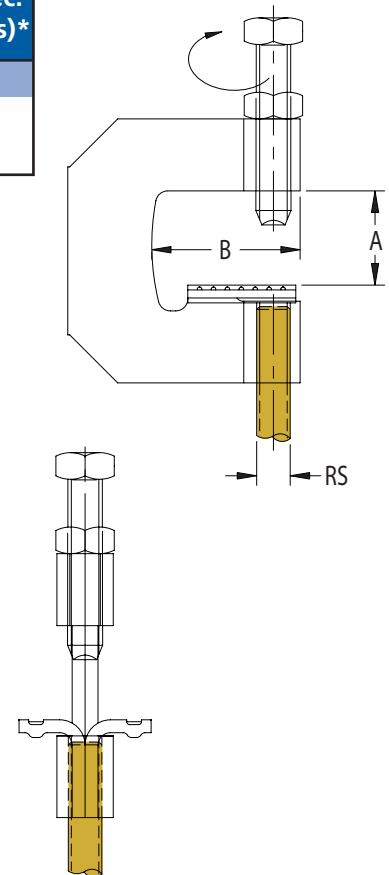

BEAM CLAMP 547/548

Steel C-clamp, Non-adjustable

- Size Range: 3/8" and 1/2" rod sizes
- Surface Finish: Black
- Designed for use with large-lip rolled steel purlins to eliminate the need to modify purlins for the standard C-clamp
- Setscrew made of hardened steel
- Setscrew must be tightened and torqued onto the sloped side of the I-beam



NOTE: Designed for "Z" Purlins.

Part Number	Model Number	RS	A	B	Set Screw	Max. Rec. Load (lbs)
Plain Finish						
5470037PL	547	3/8	1"	1-5/16"	3/8	250
5480050PL	548	1/2	1-1/8"	1-1/4"	1/2	250

Recommended Torque** (for setscrews):

Setscrew Size	1/4-20	3/8-16	1/2-13	5/8-11	3/4-10
Foot-lbs	4	5	11	21	34
Nm	(5)	(7)	(15)	(28)	(46)

**Recognizing that torque wrenches are generally not used or available on many job sites, the setscrew should be tightened so it contacts the I-beam and then an additional 1/4 to 1/2 turn added.

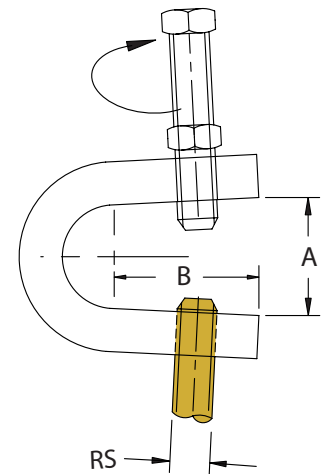

PURLIN HANGER PH

Steel Purlin Clamp EG

- Size Range: 1/4" and 3/8" rod sizes
- Surface Finish: Electro-zinc plated
- Structural attachment to bottom of purlins and beams to support threaded rod
- Setscrew made of hardened steel
- Installation screw torque: 30-inch pounds
- UL Listed* for fire protection applications (max. 3" Sch40 steel pipe)



*507P



**8N13

NOTE: Maximum flange thickness: 1/4"
Maximum recommended load: C & Z purlins: 200 lbs.,
flat flange: 160 lbs.

Part Number	RS	A	B (Min.)	Max. Rec. Load (lbs)
Electro-zinc Plated Finish				
PH4**	1/4	3/8"	3/4"	See Note
PH6**	3/8	3/8"	3/4"	See Note
PH6FP*	3/8	3/8"	3/4"	200

* Includes jam nut for fire protection applications, UL Listed for fire protection pipe (up to 3" Sch. 40 steel pipe) on purlin
**UL Listed as conduit and cable support, jam nut not included

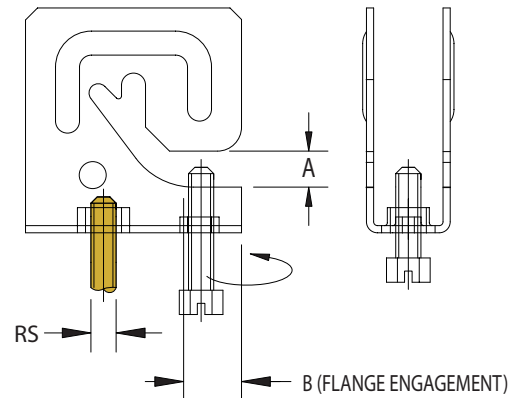

Recommended Torque[†] (for setscrews):

Setscrew Size	1/4-20	3/8-16	1/2-13	5/8-11	3/4-10
Foot-lbs	4	5	11	21	34
Nm	(5)	(7)	(15)	(28)	(46)

[†]Recognizing that torque wrenches are generally not used or available on many job sites, the setscrew should be tightened so it contacts the I-beam and then an additional 1/4 to 1/2 turn added.



PURLIN CLAMP PHSW

Steel Purlin Clamp with Swivel EG

- Size Range: 1/4" and 3/8" rod sizes
- Surface Finish: Electro-zinc plated
- Structural attachment to bottom of purlins and beams to support threaded rod
- Swivel feature option for attachment to purlins under sloped roofs
- Setscrew made of hardened steel
- Installation screw torque: 30-inch pounds
- UL Listed* for fire protection applications (max. 3" Sch40 steel pipe)



*507P



**8N13

NOTE: Maximum flange thickness: 1/4"
 Maximum recommended load: C & Z purlins: 200 lbs.,
 flat flange: 160 lbs.

Part Number	RS	A	B (Min.)	Max. Rec. Load (lbs)
Electro-zinc Plated Finish				
PHSW4**	1/4	3/8"	3/4"	See Note
PHSW6**	3/8	3/8"	3/4"	See Note
PHSW6FP*	3/8	3/8"	3/4"	200

* Includes jam nut for fire protection applications, UL Listed for fire protection pipe (up to 3" Sch. 40 steel pipe) on purlin
 **UL Listed as conduit and cable support, jam nut not included

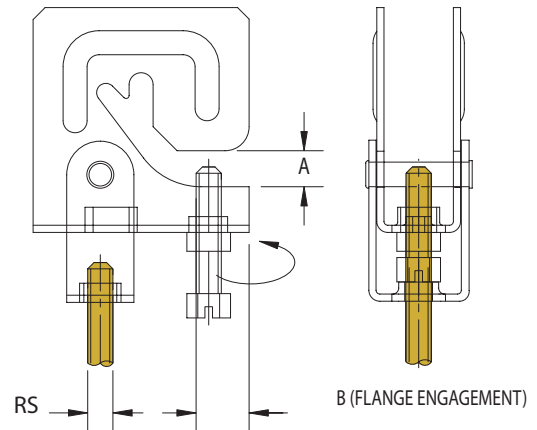

Recommended Torque[†] (for setscrews):

Setscrew Size	1/4-20	3/8-16	1/2-13	5/8-11	3/4-10
Foot-lbs	4	5	11	21	34
Nm	(5)	(7)	(15)	(28)	(46)

[†]Recognizing that torque wrenches are generally not used or available on many job sites, the setscrew should be tightened so it contacts the I-beam and then an additional 1/4 to 1/2 turn added.

BEAM CLAMP BC13

Steel Beam Clamp, Non-adjustable

- Size Range: 1/4", 5/16", 3/8", 1/2", 5/8", and 3/4" rod sizes
- Surface Finish: Electro-zinc plated
- Structural attachment to beams to support threaded rod
- Setscrew made of hardened steel
- Setscrew must be tightened and torqued onto the sloped side of the I-beam



Part Number	RS	A	B	Set Screw	Max. Rec. Load (lbs)
Electro-zinc Plated Finish					
BC130025EG	1/4	7/8"	1-1/8"	3/8	650
BC130031EG	5/16	7/8"	1-1/8"	3/8	650
BC130037EG	3/8	7/8"	1-1/8"	3/8	650
BC130050EG	1/2	7/8"	1-1/8"	1/2	1100
BC130062EG	5/8	7/8"	1-1/8"	1/2	1600
BC130075EG	3/4	7/8"	1-1/8"	5/8	2400

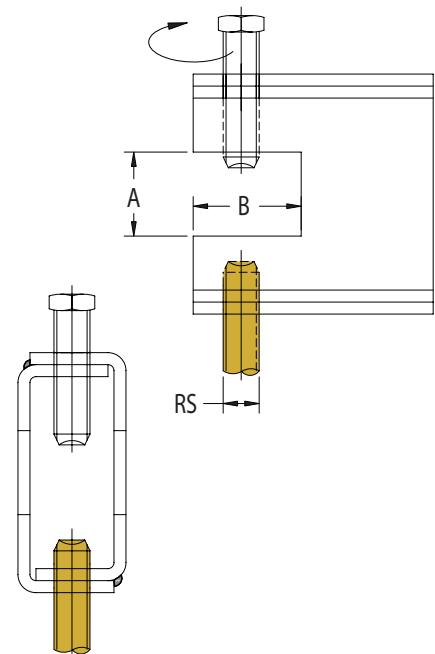

Recommended Torque* (for setscrews):

Setscrew Size	1/4-20	3/8-16	1/2-13	5/8-11	3/4-10
Foot-lbs	4	5	11	21	34
Nm	(5)	(7)	(15)	(28)	(46)

*Recognizing that torque wrenches are generally not used or available on many job sites, the setscrew should be tightened so it contacts the I-beam and then an additional 1/4 to 1/2 turn added.



BEAM CLAMP BC14

Steel Beam Clamp, Non-adjustable

- Size Range: 1/4", 3/8", 1/2" and 5/8" rod sizes
- Surface Finish: Electro-zinc plated
- Structural attachment to beams to support threaded rod
- Setscrew made of hardened steel
- Setscrew must be tightened and torqued onto the sloped side of the I-beam



Part Number	RS	A	B	Set Screw	Max. Rec. Load (lbs)
Electro-zinc Plated Finish					
BC140025EG	1/4	1-21/32"	1-5/8"	3/8	800
BC140037EG	3/8	1-21/32"	1-5/8"	3/8	800
BC140050EG	1/2	1-21/32"	1-5/8"	1/2	1300
BC140062EG	5/8	1-21/32"	1-5/8"	1/2	1900

Recommended Torque* (for setscrews):

Setscrew Size	1/4-20	3/8-16	1/2-13	5/8-11	3/4-10
Foot-lbs	4	5	11	21	34
Nm	(5)	(7)	(15)	(28)	(46)

*Recognizing that torque wrenches are generally not used or available on many job sites, the setscrew should be tightened so it contacts the I-beam and then an additional 1/4 to 1/2 turn added.

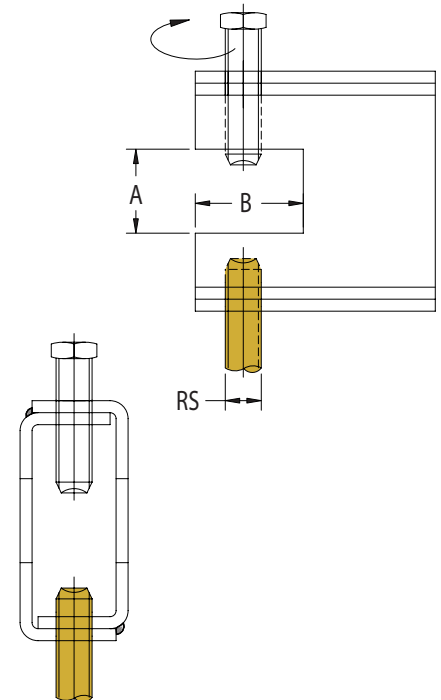

BEAM CLAMP BC10

Steel Beam Clamp, Adjustable

- Size Range: 1/4", 5/16", 3/8" and 1/2" rod sizes
- Surface Finish: Electro-zinc plated
- Structural attachment to beams to support threaded rod
- Setscrew made of hardened steel
- Setscrew must be tightened and torqued onto the sloped side of the I-beam

Part Number	RS	A	B	Set Screw	Max. Rec. Load (lbs)
Electro-zinc Plated Finish					
BC100000EG	1/4, 5/16, 3/8, or 1/2	3/4"	1"	3/8	See Note*

*Maximum recommended load: Position A – 500 lbs
Position B – 300 lbs

Recommended Torque** (for setscrews):

Setscrew Size	1/4-20	3/8-16	1/2-13	5/8-11	3/4-10
Foot-lbs	4	5	11	21	34
Nm	(5)	(7)	(15)	(28)	(46)

**Recognizing that torque wrenches are generally not used or available on many job sites, the setscrew should be tightened so it contacts the I-beam and then an additional 1/4 to 1/2 turn added.

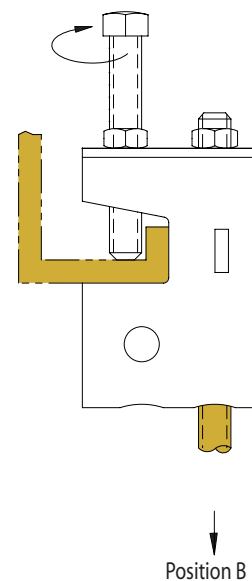
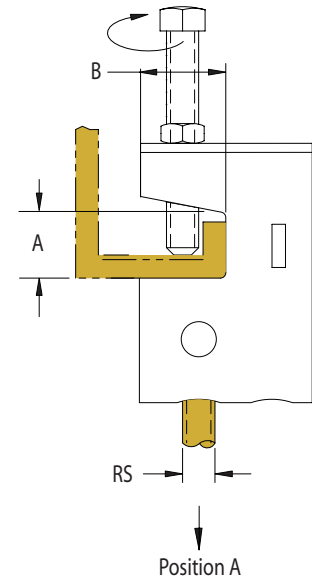

BEAM CLAMP SWIVEL BC15

Beam Clamp Swivel for BC10

- Size Range: 1/4", 3/8", and 1/2" rod sizes
- Surface Finish: Electro-zinc plated
- Swivel attachment for use with BC10 Beam Clamp
- Setscrew made of hardened steel
- Setscrew must be tightened and torqued onto the sloped side of the I-beam



Part Number	RS	A	B	Set Screw	Max. Rec. Load (lbs)
Electro-zinc Plated Finish					
BC101500EG	1/4, 3/8, & 1/2	3/4"	1"	3/8	500

Recommended Torque* (for setscrews):

Setscrew Size	1/4-20	3/8-16	1/2-13	5/8-11	3/4-10
Foot-lbs	4	5	11	21	34
Nm	(5)	(7)	(15)	(28)	(46)

*Recognizing that torque wrenches are generally not used or available on many job sites, the setscrew should be tightened so it contacts the I-beam and then an additional 1/4 to 1/2 turn added.

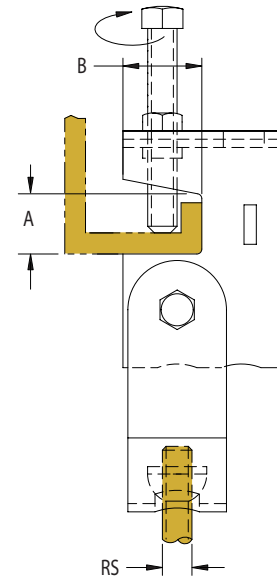

RETAINER STRAP BC09

Beam Clamp Retainer Strap for BC Series

- Size Range: 9", 12", and 15" lengths
- Surface Finish: Electro-zinc plated
- Retainer strap for BC13 / BC14 beam clamps

Part Number	A	Flange Width
BC090900EG	9"	6"
BC091200EG	12"	9"
BC091500EG	15"	12"

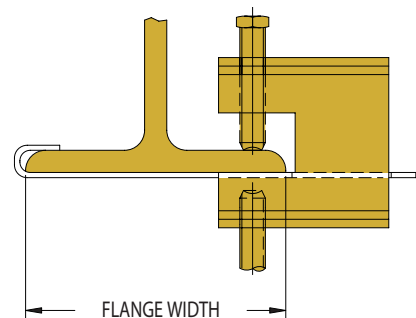
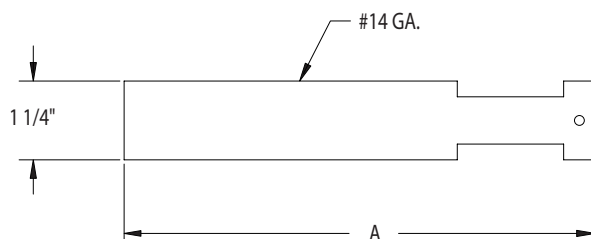

PURLIN HANGER 315

Malleable Iron Purlin Clamp Black

- Size Range: 3/8" rod size
- Surface Finish: Black, Electro-zinc plated
- Structural attachment to lower flange of metal beams or purlins with 45° flanges up to 2" long and 90° flanges up to 1-1/2" high
- Set screw made of hardened steel
- Conforms with Federal Specification WW-H-171 (Type 23), Manufacturers Standardization Society ANSI/MSS-SP-58 (Type 23); install in accordance with ANSI/MSS-SP-69
- Setscrew must be tightened and torqued onto the sloped side of the I-beam



Part Number	RS	A	B	C	Set Screw	Max. Pipe Size	Max. Rec. Load (lbs)
Plain Finish							
3150037PL	3/8	2"	1-1/2"	1"	3/8"	4"	400
Electro-zinc Plated Finish							
3150037EG	3/8	2"	1-1/2"	1"	3/8"	4"	400



Recommended Torque** (for setscrews):

Setscrew Size	1/4-20	3/8-16	1/2-13	5/8-11	3/4-10
Foot-lbs	4	5	11	21	34
Nm	(5)	(7)	(15)	(28)	(46)

**Recognizing that torque wrenches are generally not used or available on many job sites, the setscrew should be tightened so it contacts the I-beam and then an additional 1/4 to 1/2 turn added.

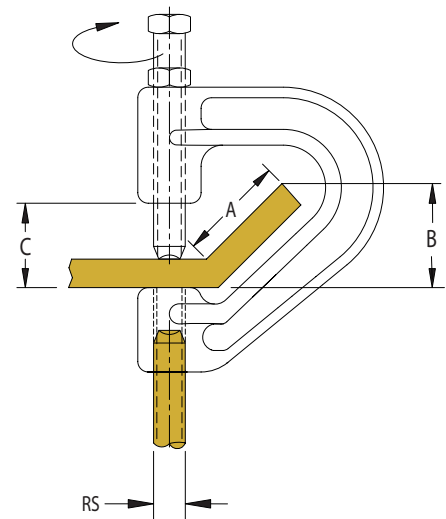

PARALLEL PIPE CLAMP PAR

Malleable Iron, HD

- Size Range: 3/8" – 4"
- Surface Finish: Hot-dip galvanized
- Structural attachments of pipe sizes from 3/8" - 4" to beams with up to 3/4" flange thickness



Part Number	Nominal Pipe Size	A
PAR0037HD	3/8"	3/4"
PAR0050HD	1/2"	3/4"
PAR0075HD	3/4"	3/4"
PAR0100HD	1"	3/4"
PAR0125HD	1-1/4"	3/4"
PAR0150HD	1-1/2"	3/4"
PAR0200HD	2"	3/4"
PAR0250HD	2-1/2"	3/4"
PAR0300HD	3"	3/4"
PAR0350HD	3-1/2"	3/4"
PAR0400HD	4"	3/4"

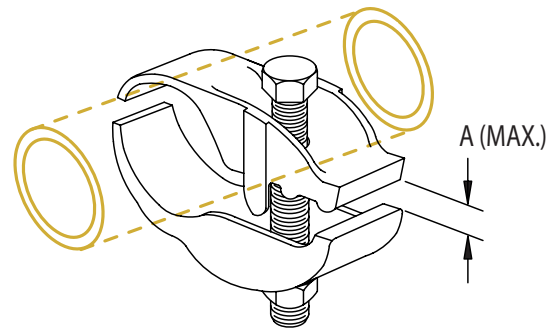

EDGE TYPE PIPE CLAMP ET

Malleable Iron, HD

- Size Range: 1/2" – 3"
- Surface Finish: Hot-dip galvanized
- Structural attachments of pipe sizes from 1/2" - 3" to beams with up to 3/4" flange thickness



Part Number	Nominal Pipe Size	A
ET0050HD	1/2"	3/4"
ET0075HD	3/4"	3/4"
ET0100HD	1"	3/4"
ET0125HD	1-1/4"	3/4"
ET0150HD	1-1/4"	3/4"
ET0200HD	2"	3/4"
ET0250HD	2-1/2"	3/4"
ET0300HD	3"	3/4"

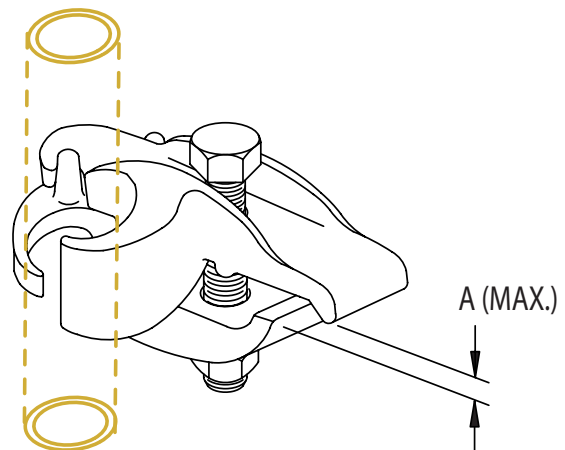

RIGHT ANGLE PIPE SUPPORT RA

Malleable Iron, HD

- Size Range: 3/8" – 4"
- Surface Finish: Hot-dip galvanized
- Structural attachments of pipe sizes from 3/8" - 4" to beams with up to 3/4" flange thickness



Part Number	Nominal Pipe Size	A	Max. Rec. Load (lbs)
RA0037HD	3/8"	3/4"	200
RA0050HD	1/2"	3/4"	250
RA0075HD	3/4"	3/4"	300
RA0100HD	1"	3/4"	400
RA0125HD	1-1/4"	3/4"	400
RA0150HD	1-1/2"	3/4"	500
RA0200HD	2"	3/4"	600
RA0250HD	2-1/2"	3/4"	700
RA0300HD	3"	3/4"	800
RA0350HD	3-1/2"	3/4"	900
RA0400HD	4"	3/4"	1000

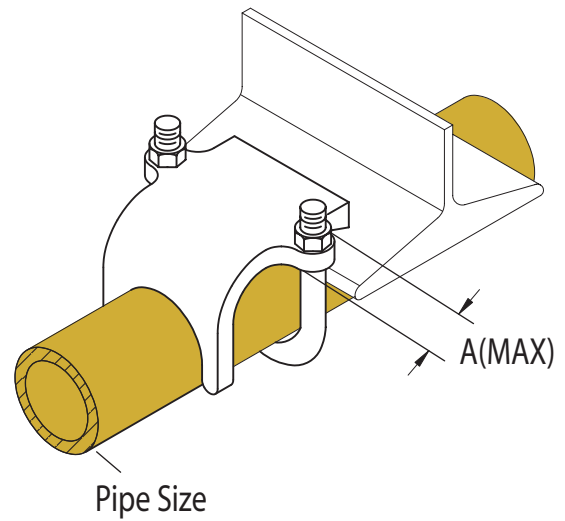

RETAINER STRAP 300C

Beam Clamp Retainer Strap for 300 / 310 Series

- Size Range: 3/8", 1/2", 5/8", 3/4" and 7/8" rod sizes
- Surface Finish: Electro-zinc plated
- Retainer strap for Model 300 / 310 beam clamps
- Available in a HD finish by special order

NOTE: Field bend and use jam nut over hanger rod to secure.

NOTE: Add 2" to width of flange to determine minimum length strap required. Specify rod size and length.

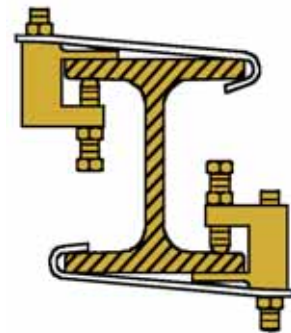

Part Number	RS	A	B
300C3706EG	3/8	6"	15/16"
300C3708EG	3/8	8"	15/16"
300C3710EG	3/8	10"	15/16"
300C3712EG	3/8	12"	15/16"
300C3714EG	3/8	14"	15/16"
300C3716EG	3/8	16"	15/16"
300C3718EG	3/8	18"	15/16"
300C5008EG	1/2	8"	15/16"
300C5010EG	1/2	10"	15/16"
300C5012EG	1/2	12"	15/16"
300C5014EG	1/2	14"	15/16"
300C5016EG	1/2	16"	15/16"
300C6206EG	5/8	6"	1-3/16"
300C6208EG	5/8	8"	1-3/16"
300C6210EG	5/8	10"	1-3/16"
300C6212EG	5/8	12"	1-3/16"
300C6214EG	5/8	14"	1-3/16"
300C7506EG	3/4	6"	1-3/16"
300C7508EG	3/4	8"	1-3/16"
300C7510EG	3/4	10"	1-3/16"
300C7514EG	3/4	14"	1-3/16"
300C8706EG	7/8	6"	2"
300C8708EG	7/8	8"	2"
300C8710EG	7/8	10"	2"
300C8714EG	7/8	14"	2"

RETAINER STRAP 35RS

Beam Clamp Retainer Strap for 300 / 310 Series

- Size Range: 3/8" or 1/2" rod sizes
- Surface Finish: Electro-zinc plated
- Retainer strap for Model 300 / 310 beam clamps
- Available in a HD finish by special order

NOTE: Field bend and use jam nut over hanger rod to secure.

NOTE: Add 2" to width of flange to determine minimum length strap required. Specify rod size and length.



Part Number	RS	A	B
035RS0600EG	3/8 or 1/2	6"	15/16"
035RS0800EG	3/8 or 1/2	8"	15/16"
035RS1000EG	3/8 or 1/2	10"	15/16"
035RS1200EG	3/8 or 1/2	12"	15/16"
035RS1400EG	3/8 or 1/2	14"	15/16"
035RS1600EG	3/8 or 1/2	16"	15/16"
035RS1800EG	3/8 or 1/2	18"	15/16"
035RS2000EG	3/8 or 1/2	20"	15/16"

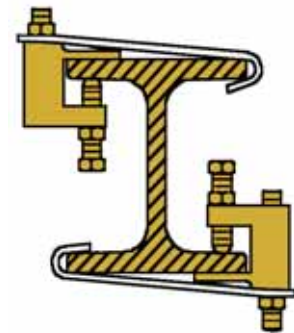

RETAINER STRAP 34SL

Retrofit Beam Clamp Retainer Strap for 300 / 310 Series

- Size Range: 3/8" rod size
- Surface Finish: Electro-zinc plated
- Retrofit retainer strap for Model 300 / 310 beam clamps

NOTE: Field bend and use jam nut over hanger rod to secure.

NOTE: Add 2" to width of flange to determine minimum length strap required. Specify rod size and length.



Part Number	RS	A	B
034SL0600EG	3/8	6"	1-3/8"
034SL0800EG	3/8	8"	1-3/8"
034SL1000EG	3/8	10"	1-3/8"
034SL1200EG	3/8	12"	1-3/8"
034SL1400EG	3/8	14"	1-3/8"

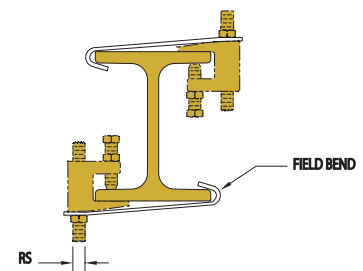
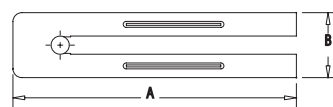

RETAINER STRAP 255C

Beam Clamp Retainer Strap for 255 Series

- Size Range: 3/8", 1/2", and 5/8" rod sizes
- Surface Finish: Electro-zinc plated
- Utilized when a retainer strap is specified with Model #255 or #255L beam clamps

NOTE: Field bend and use jam nut over hanger rod to secure.

NOTE: Add 2" to width of flange to determine minimum length strap required. Specify rod size and length.



Part Number	RS	A	B
255C3706EG	3/8	6"	1-1/4"
255C3708EG	3/8	8"	1-1/4"
255C3710EG	3/8	10"	1-1/4"
255C3714EG	3/8	14"	1-1/4"
255C5006EG	1/2	6"	1-1/4"
255C5008EG	1/2	8"	1-1/4"
255C6210EG	5/8	10"	1-1/4"
255C6214EG	5/8	14"	1-1/4"

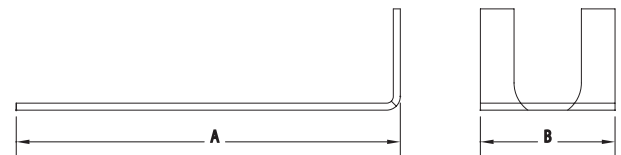

WOOD BEAM CLAMP 356

Steel Clamp for Wood Beams

- Size Range: B x D joist sizes
- Surface Finish: Black
- Structural attachment for hanging from a "Truss Joist" type of wood beam
- For use with Models #40 Eye Rod or #37 Eye Socket

NOTE: B x C dimensions equal the joist size

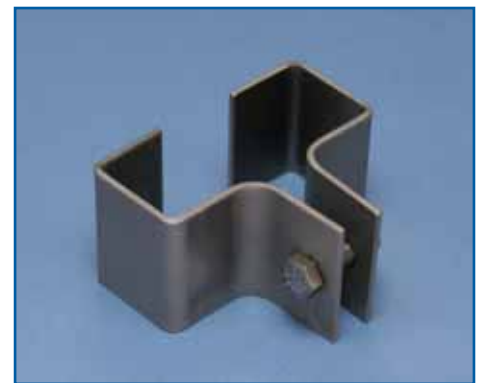

Part Number	Size	A	B	C	Max. Rec. Load (lbs)
3560100PL	1	3-5/16"	1-1/2"	2-5/16"	250
3560200PL	2	3-9/16"	1-3/4"	2-1/2"	250
3560300PL	3	3-5/16"	1-1/2"	1-3/4"	250
3560400PL	4	3-5/16"	1-1/2"	3-1/2"	250
3560500PL	5	4-5/16"	2-1/2"	3-1/2"	250

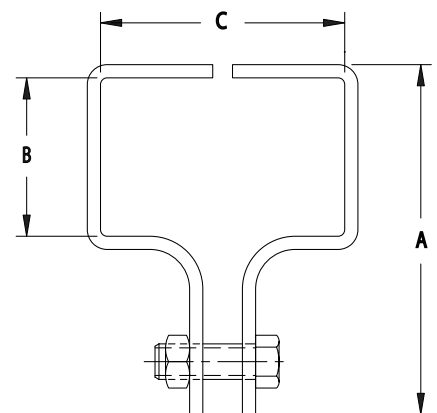

BEAM CLAMP 360

Malleable Iron Adjustable Center-Load Beam Clamp

- Size Range: 3/8", 1/2", 5/8", 3/4", and 7/8" rod sizes
- Surface Finish: Black
- Structural attachment to support hanger rod beneath the center of a beam
- Accommodates 2-3/8" thru 7" wide beams with a maximum 0.60-inch flange thickness
- Use with Model #26 extension piece (not included)
- Conforms with Federal Specification WW-H-171 (Type 30), Manufacturers Standardization Society ANSI/MSS-SP-58 (Type 30); install in accordance with ANSI/MSS-SP-69



NOTE: Available with an EG finish by special order

P/N 3600000PL								Max. Pipe Size	Max. Rec. Load (lbs)
RS	A=2-3/8"	A=3"	A=4"	A=5"	A=6"	A=7"	C		
	B	B	B	B	B	B			
3/8	4-3/4"	4-3/4"	4-1/2"	4-1/8"	3-7/8"	3-1/8"	7/8"	2"	610
1/2	4-7/8"	4-3/4"	4-3/4"	4-1/4"	4"	3-1/4"	15/16"	3-1/2"	1130
5/8	4-15/16"	4-7/8"	4-3/4"	4-3/8"	4"	3-15/16"	1-3/8"	5"	1365
3/4	5-3/16"	5-1/8"	5"	4-5/8"	4-1/4"	3-9/16"	1-3/8"	6"	1365
7/8	5-1/4"	5-1/4"	5-1/16"	4-3/4"	4-3/8"	3-5/8"	1-1/4"	12"*	1365

*Reduced hanger spacing is required when supporting 10" and 12" pipe

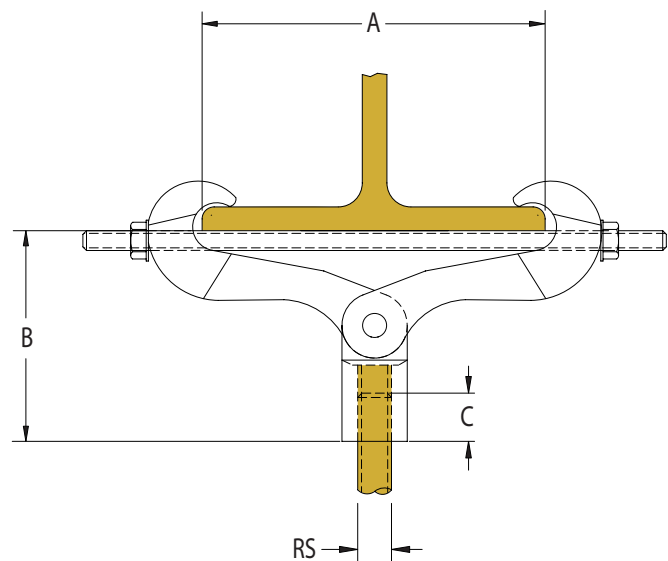

BEAM CLAMP 361

Steel Center-Load Beam Clamp

- Size Range: 4" thru 8" wide beam
- Surface Finish: Black
- Structural attachment to support hanger rod beneath the center of a beam using Models #40 Eye Rod or #35 Eye Nut
- Conforms with Federal Specification WW-H-171 (Type 21), Manufacturers Standardization Society ANSI/MSS-SP-58 (Type 21); install in accordance with ANSI/MSS-SP-69



Part Number*	BS	A Rec. Flange Thickness	B	C	Max. Rec. Load (lbs)
361024050PL	1/2 x 1-3/4	1/2"	4"	5/8"	700
361025062PL	1/2 x 1-3/4	5/8"	5"	5/8"	700
361026075PL	1/2 x 1-3/4	3/4"	6"	5/8"	700
361027087PL	1/2 x 1-3/4	7/8"	7"	5/8"	700
361028087PL	1/2 x 1-3/4	7/8"	8"	5/8"	700
361054050PL	3/4 x 2-3/4	1/2"	4"	7/8"	1500
361055062PL	3/4 x 2-3/4	5/8"	5"	7/8"	1500
361056075PL	3/4 x 2-3/4	3/4"	6"	7/8"	1500
361057087PL	3/4 x 2-3/4	7/8"	7"	7/8"	1500
361058087PL	3/4 x 2-3/4	7/8"	8"	7/8"	1500

*These part numbers encompass only types 2 and 5 of this product offering

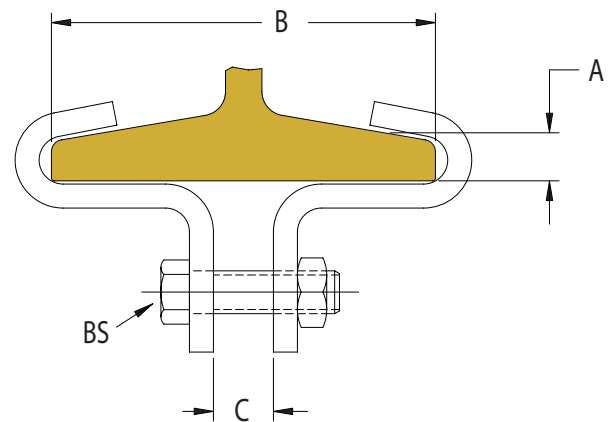

BEAM CLAMP 363

Adjustable Steel Center-Load Beam Clamp









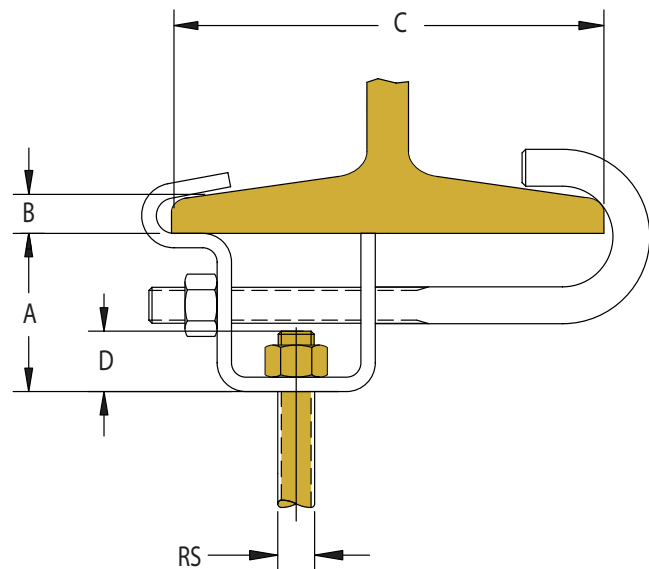



- Size Range: 3/8", 1/2", 5/8", and 3/4" rod sizes
- Surface Finish: Black
- Structural attachment to support hanger rod under beams of various flange width
- Conforms with Federal Specification WW-H-171 (Type 54), Manufacturers Standardization Society ANSI/MSS-SP-58 (Type 27), install in accordance with ANSI/MSS-SP-69



NOTE: Available with an EG finish by special order

Part Number	RS	A	B	C	D	Max Pipe Size	Max. Rec. Load (lbs)
3630037PL	3/8	2-3/4"	5/8"	3-1/2 - 8"	11/16"	2"	300
3630050PL	1/2	2-3/4"	5/8"	3-1/2 - 8"	13/16"	4"	700
3630062PL	5/8	2-3/4"	5/8"	3-1/2 - 8"	15/16"	8"	1000
3630075PL	3/4	2-3/4"	5/8"	3-1/2 - 8"	15/16"	8"	1000



			
Page 117	Page 117	Page 118	Page 119
365M	365	355	355N
			
Page 120	Page 121	Page 122	Page 123
370A	37	38	325
			
Page 124	Page 125	Page 126	Page 127
326	327	328	319

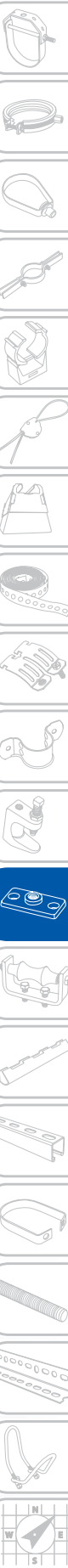
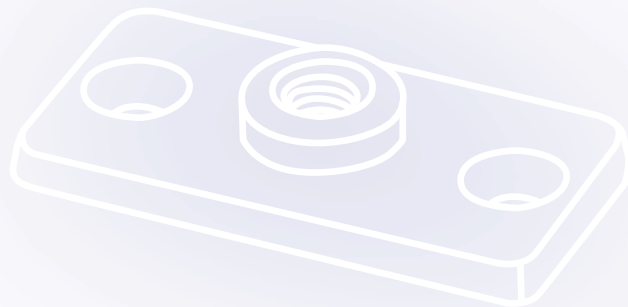

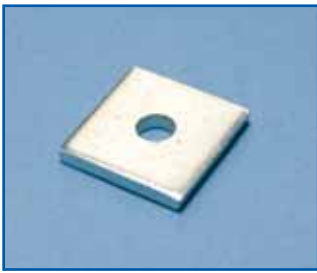

Page 127

340



Page 128

320L / 320W



Page 129

348

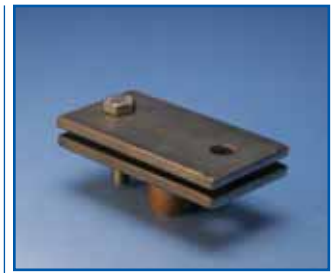

Page 130

350



Page 130

351



Page 131

352



Page 132

353



Page 133

4TI/6TI



Page 133

AF



Page 134

VF



Page 134

VAFT

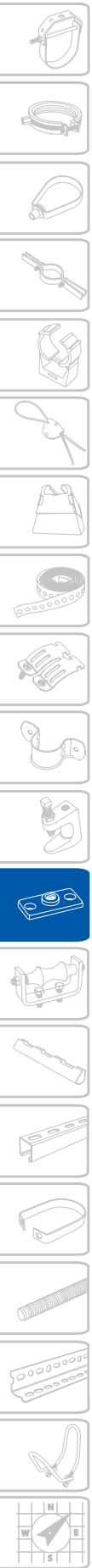
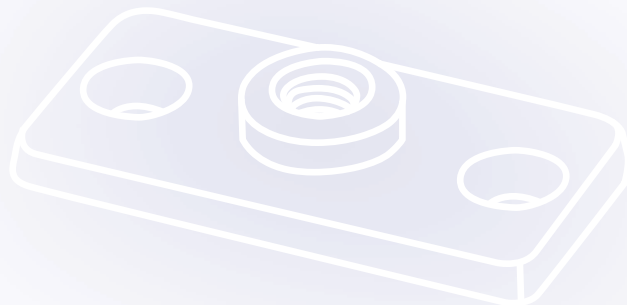

CEILING OR WALL PLATE 365M

Malleable Iron Ceiling or Wall Plate

- Size Range: 3/8" or 1/2" rod size
- Surface Finish: Electro-zinc plated, Black, Copper-colored coating (for identification purposes only)
- Structural attachment to support hanger rod from a ceiling or a wall

NOTE: Follow fastener manufacturer's recommended shear and pull-out strength when fastening to the structure.



Part Number	RS	A	Max. Pipe Size	Max. Rec. Load (lbs)
Plain Finish				
365M0037PL	3/8"	15/32"	2"	180
365M0050PL	1/2"	15/32"	3-1/2"	180
Electro-zinc Plated				
365M0037EG	3/8"	15/32"	2"	180
365M0050EG	1/2"	15/32"	3-1/2"	180
Copper-colored				
365M0037CP	3/8"	15/32"	2"	180
365M0050CP	1/2"	15/32"	3-1/2"	180

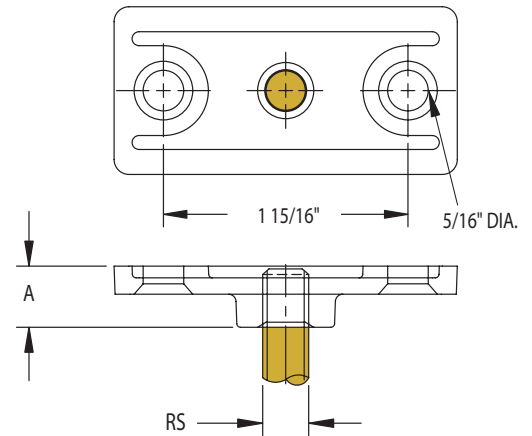

CEILING OR WALL PLATE 365

Steel Ceiling or Wall Plate

- Size Range: 3/8" rod size
- Surface Finish: Electro-zinc plated, Black, Copper-colored coating (for identification purposes only)
- Structural attachment to support hanger rod from a ceiling or a wall

NOTE: Follow fastener manufacturer's recommended shear and pull-out strength when fastening to the structure.



Part Number	RS	A	Max. Pipe Size	Max. Rec. Load (lbs)
Plain Finish				
3650037PL	3/8"	5/16"	2"	100
Electro-zinc Plated				
3650037EG	3/8"	5/16"	2"	100
Copper-colored				
3650037CP	3/8"	5/16"	2"	100

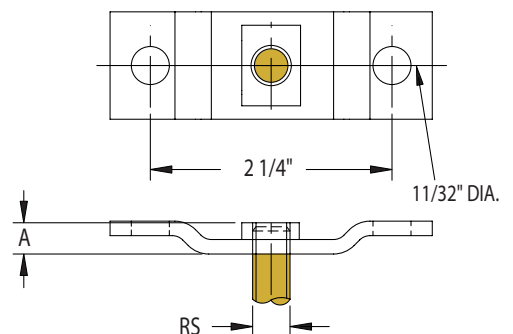

CONCRETE INSERT 355

Steel Insert Plate

- Size Range: Maximum 7/8" rod size
- Surface Finish: Electro-zinc plated, Black
- Structural attachment in all grades of concrete
- Knockout keeps interior empty during pour
- Allows for horizontal rod adjustment up to 1-1/4"
- Installation: Place knockout side down on concrete form and nail in place. Wire 12" piece of #4 reinforcing rod on both sides. After concrete pour, knockout can be removed with a screwdriver.
- Use with Model #355N Insert Nut (for UL Listing) or Models: #Nut, #SPRA, #SPRC strut nuts. Rod should be threaded through the nut until it tightens against the top of the insert
- Conforms with Federal Specification WW-H-171 (Type 19), Manufacturers Standardization Society ANSI/MSS-SP-58 (Type 18); install in accordance with ANSI/MSS-SP-69



3/8, 1/2, 5/8, 3/4 in.
rod for pipe size 6 in. max.



Part Number	Max. RS	A	B	C	Max. Pipe Size	Max. Rec. Load (lbs)
Plain Finish						
3550000PL	7/8"	1-5/8"	3-9/16"	3"	10"	1200
Electro-zinc Plated						
3550000EG	7/8"	1-5/8"	3-9/16"	3"	10"	1200

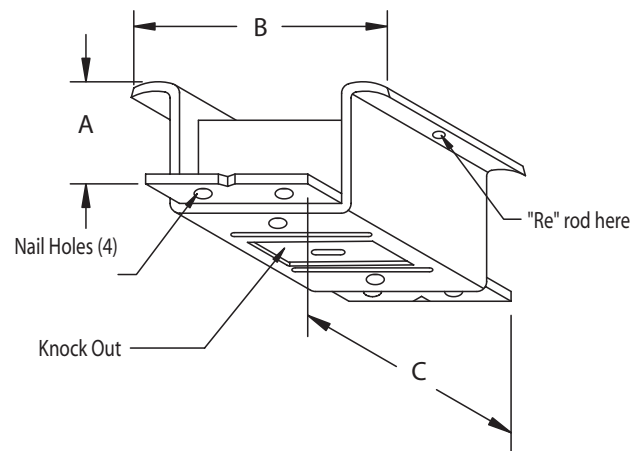

CONCRETE INSERT NUT 355N

Steel Insert Nut

- Size Range: 1/4", 3/8", 1/2", 5/8", 3/4", and 7/8" rod sizes
- Surface Finish: Electro-zinc plated, Black
- Hanger rod attachment to be installed inside of the Model #355 Concrete Insert
- Installation: See Model #355
- Conforms with Federal Specification WW-H-171 (Type 19), Manufacturers Standardization Society ANSI/MSS-SP-58 (Type 18); install in accordance with ANSI/MSS-SP-69

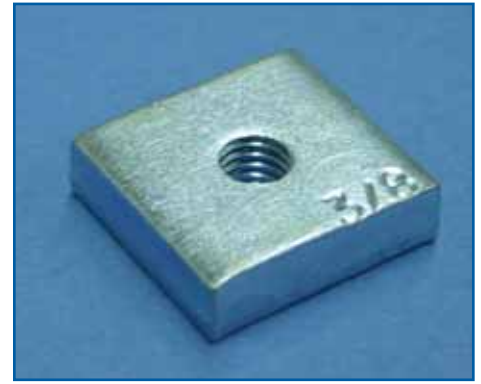

Part Number	RS	Max. Pipe Size	Max. Rec. Load (lbs)
Plain Finish			
355N0025PL	1/4"	N/A	240
355N0037PL	3/8"	4"	610
355N0050PL	1/2"	8"	1130
355N0062PL	5/8"	8"	1200
355N0075PL	3/4"	8"	1200
355N0087PL*	7/8"	10"	1200
Electro-zinc Plated			
355N0025EG	1/4"	N/A	240
355N0037EG	3/8"	4"	610
355N0050EG	1/2"	8"	1130
355N0062EG	5/8"	8"	1200
355N0075EG	3/4"	8"	1200
355N0087EG*	7/8"	10"	1200

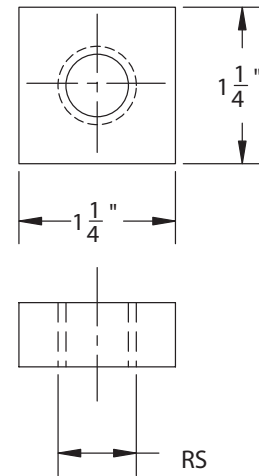

*Reduced support spacing is required

CONCRETE INSERT 370A

Steel Insert Plate and Rod

- Size Range: 3/8", 1/2", 5/8", 3/4", and 7/8" rod sizes
- Surface Finish: Black
- Structural attachment to support hanger rod from metal deck-poured concrete ceiling where adjustment for concrete thickness is needed
- Threaded rod supplied with an EG finish



NOTE: Maximum load ratings are dependent on many factors, which include, but are not limited to: type of concrete, depth of slab, location of anchor in slab, and depth of anchor in slab. Consult a professional engineer regarding anchor positioning.

Part Number	RS	Plate Size	Max. Rec. Load (lbs)
370A0037PL	3/8" x 8"	1-1/4" x 10"	240
370A0050PL	1/2" x 8"	1-1/4" x 10"	240
370A0062PL	5/8" x 8"	1-1/4" x 10"	610
370A0075PL	3/4" x 12"	2" x 5"	610
370A0087PL	7/8" x 12"	3" x 8"	1130

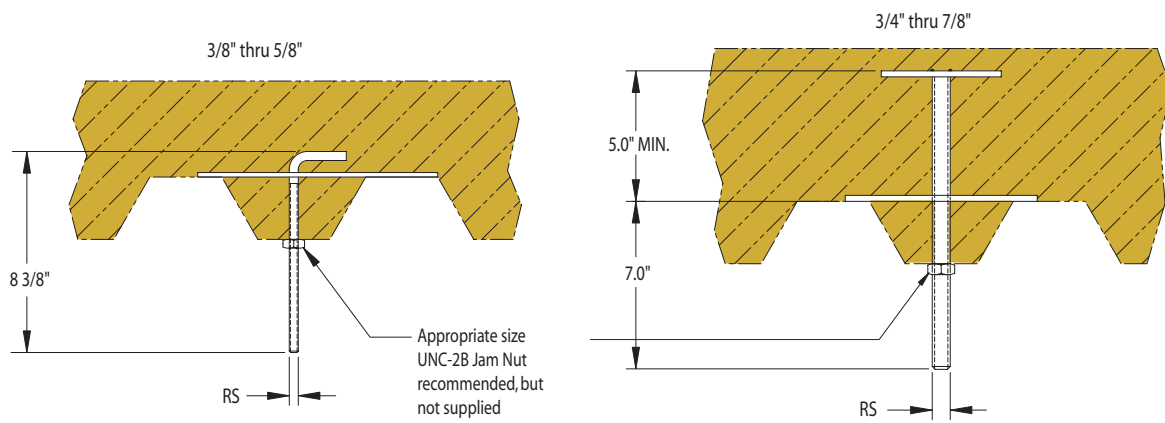

Bottom plate is threaded to allow vertical adjustment of the anchor rod.



ROD HANGER 37

Steel Eye Socket

- Size Range: 3/8" and 1/2" rod sizes
- Surface Finish: Electro-zinc plated
- Structural attachment used to join hanger rod to a structure



NOTE:

1. Fastener sizes for 3/8" rod size
 - a. Thru 2" pipe, two Model #43 Wood Drive Screws
 - b. Thru 4" pipe, one Model #42 1/2 x 3" Lag Screw
2. Fastener size for 1/2" rod size: thru 8" pipe, one Model #42 5/8 x 3" Lag Screw

Part Number	RS	A	B	C	D	E	Max. Pipe Size	Max. Rec. Load (lbs)*
0370037EG	3/8"	2-1/4"	1/2"	1/4"	1-1/8"	1-1/8"	4"	250
0370050EG	1/2"	2-3/4"	11/16"	None	1-3/16"	1-1/2"	8"	760

*Load rating dependent on wood structure strength

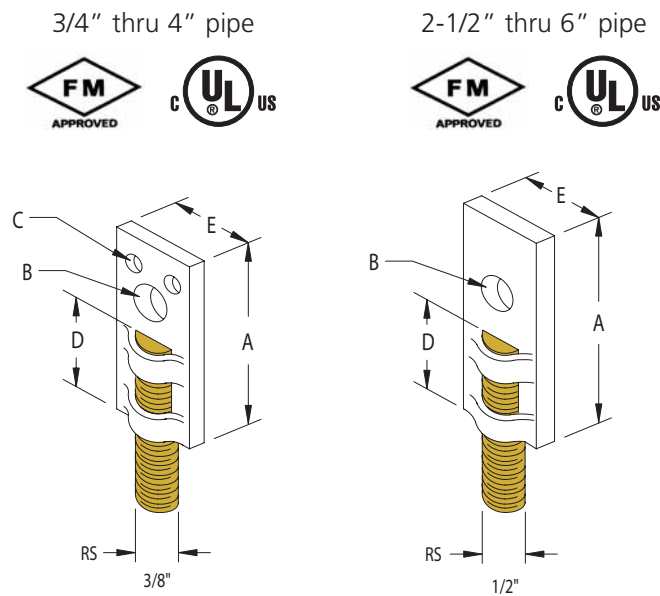

ROD HANGER 38

Offset Steel Eye socket

- Size Range: 3/8" rod size
- Surface Finish: Electro-zinc plated
- Structural attachment used to join hanger rod to a structure
- Provides full vertical rod adjustment

NOTE:

1. Fastener sizes for 3/8" rod size
 - a. Thru 2" pipe, two Model #43 Wood Drive Screws
 - b. Thru 4" pipe, one Model #42 1/2 x 3" Lag Screw



Part Number	RS	A	B	C	D	E	Max. Pipe Size	Max. Rec. Load (lbs)
0380037EG	3/8"	3-1/4"	1/2"	1/4"	1-3/16"	1-1/8"	4"	250

*Load rating dependent on wood structure strength

3/4" thru 4" pipe

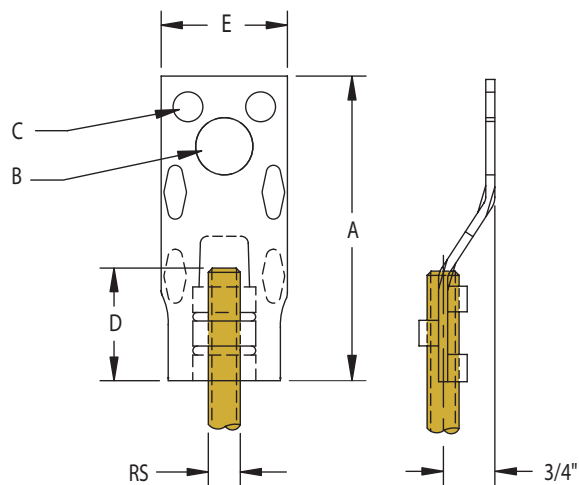

ROD HANGER 325

Steel Side Beam Attachment

- Size Range: 3/8", 1/2", 5/8", 3/4", 7/8", and 1" rod sizes
- Surface Finish: Electro-zinc plated, Black
- Structural attachment fastened to the wall or the side of a joist to support hanger rod
- Conforms with Federal Specification WW-H-171 (Type 35), Manufacturers Standardization Society ANSI/MSS-SP-58 (Type 34); install in accordance with ANSI/MSS-SP-69

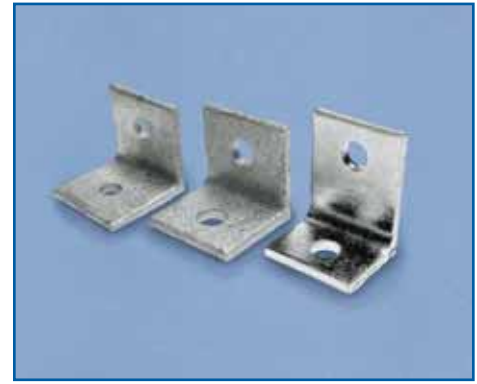

NOTE: Follow fastener manufacturer's recommended shear and pull-out strength when fastening to the structure.

Part Number	RS	A	B	Max. Rec. Load (lbs)	
				w/ Lag Screw	w/ Bolt to Steel
Plain Finish					
3250037PL	3/8"	1-5/32"	7/16"	650	1150
3250050PL	1/2"	1-5/32"	9/16"	650	1150
3250062PL	5/8"	1-3/8"	11/16"	850	2000
3250075PL	3/4"	1-3/4"	13/16"	900	3500
3250087PL	7/8"	2-1/2"	15/16"	900	3600
3250100PL	1"	2-1/2"	1-1/16"	900	3700
Electro-zinc Plated					
3250037EG	3/8"	1-5/32"	7/16"	650	1150
3250050EG	1/2"	1-5/32"	9/16"	650	1150
3250062EG	5/8"	1-3/8"	11/16"	850	2000
3250075EG	3/4"	1-3/4"	13/16"	900	3500
3250087EG	7/8"	2-1/2"	15/16"	900	3600
3250100EG	1"	2-1/2"	1-1/16"	900	3700

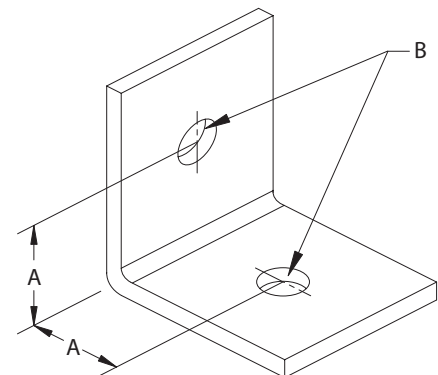

ROD HANGER 326

Universal Steel Side Beam Attachment

- Size Range: 3/8" rod size
- Surface Finish: Electro-zinc plated, Black
- Structural attachment fastened to the wall or the side of a joist to support hanger rod, where either 3/8" or 1/2" fasteners can be used to reduce inventories
- Conforms with Federal Specification WW-H-171 (Type 35), Manufacturers Standardization Society ANSI/MSS-SP-58 (Type 34); install in accordance with ANSI/MSS-SP-69



NOTE: Follow fastener manufacturer's recommended shear and pull-out strength when fastening to the structure.

Part Number	RS	A	B	Max. Rec. Load (lbs)	
				w/ Lag Screw	w/ Bolt to Steel
Plain Finish					
3260037PL	3/8"	1-5/32"	7/16"	560	620
Electro-zinc Plated					
3260037EG	3/8"	1-5/32"	7/16"	560	620

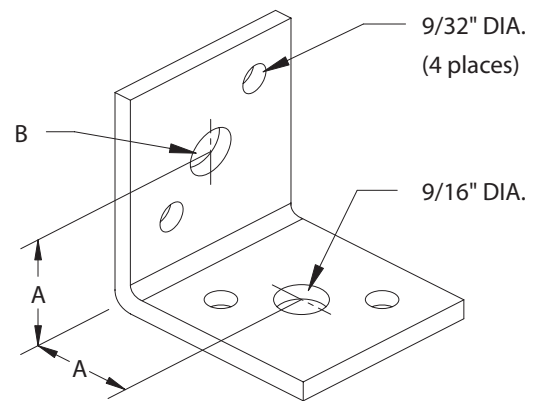

ROD HANGER 327

Malleable Iron Side Beam Connector

- Size Range: 3/8" and 1/2" rod sizes
- Surface Finish: Electro-zinc plated, Black
- Pre-threaded structural attachment fastened to wall or the side of a joist to support hanger rod where two #43 Wood Drive Screws are necessary for proper support



NOTE: Follow fastener manufacturer's recommended shear and pull-out strength when fastening to the structure.

Part Number	RS	A	B	C	Max. Rec. Load (lbs)*
Plain Finish					
3270037PL	3/8"	2-3/8"	15/16"	#14	250
3270050PL	1/2"	2-3/4"	1-5/16"	#16	480
Electro-zinc Plated					
3270037EG	3/8"	2-3/8"	15/16"	#14	250
3270050EG	1/2"	2-3/4"	1-5/16"	#16	480

*Load rating dependent on wood structure strength

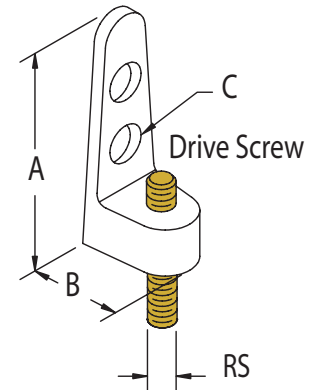

ROD HANGER 328

Threaded Steel Side Beam Connector

- Size Range: 3/8" and 1/2" rod sizes
- Surface Finish: Electro-zinc plated, Black
- Pre-threaded structural attachment fastened to wall or the side of a joist to support hanger rod
- Conforms with Federal Specification WW-H-171 (Type 35), Manufacturers Standardization Society ANSI/MSS-SP-58 (Type 34); install in accordance with ANSI/MSS-SP-69



NOTE: Follow fastener manufacturer's recommended shear and pull-out strength when fastening to the structure.

Part Number	RS	Max. Rec. Load (lbs)	
		w/ Lag Screw	w/ Bolt to Steel
Plain Finish			
3280037PL	3/8"	560	620
3280050PL	1/2"	560	620
Electro-zinc Plated			
3280037EG	3/8"	560	620

1" thru 4" pipe

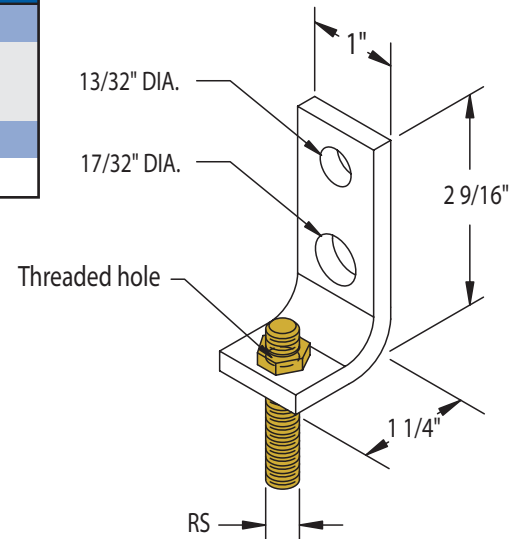

ROD HANGER 319

Steel Return Line Angle Bracket

- Size Range: 2-5/8" thru 3-5/8" from wall
- Surface Finish: Black
- Structural wall attachment to support hanger rod designed to keep the centerline of the pipe either 2", 3", or 4" away from the wall

NOTE: Follow fastener manufacturer's recommended shear and pull-out strength when fastening to the structure



Part Number	A	B	Max. Rec. Load (lbs)
3190100PL	2-5/8"	3-5/8"	180
3190200PL	3-5/8"	4-5/8"	180

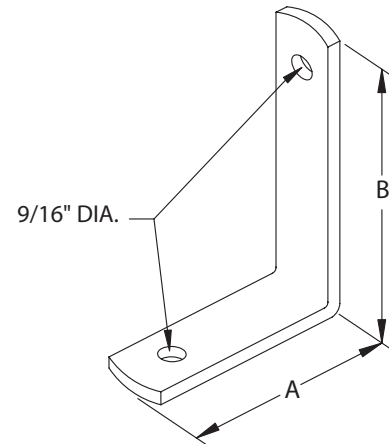

WASHER PLATE 340

Square Steel Washer

- Size Range: 3/8", 1/2", 5/8", 3/4", and 7/8" rod sizes
- Surface Finish: Electro-zinc plated
- Square steel washer plate used on top of channel or angle for hanger rod or U-bolt attachment

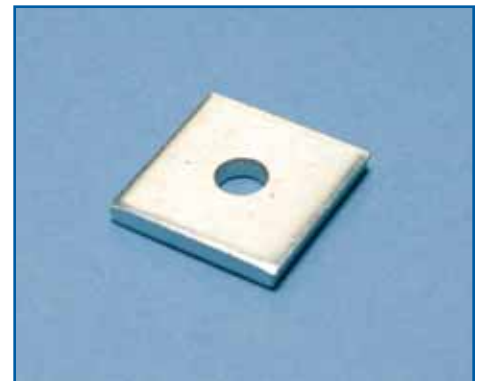

Part Number	RS	A	B	C
340A2503PL	3/8"	7/16"	1/4"	3"
340B2503PL	1/2"	9/16"	1/4"	3"
340C3703PL	5/8"	11/16"	3/8"	3"
340D3704PL	3/4"	13/16"	3/8"	4"
340E5004PL	7/8"	15/16"	1/2"	4"

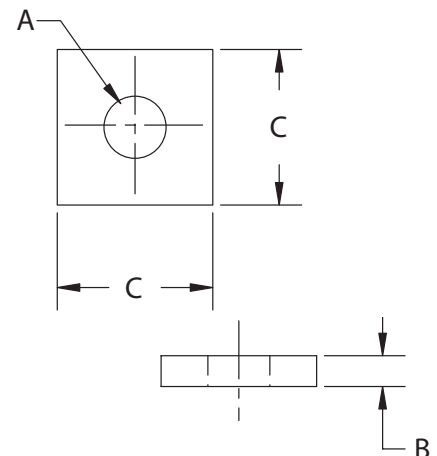

ROD HANGER 320L / 320W

Welded Beam Attachment

- Size Range: 3/8" thru 2-1/2" rod sizes
- Surface Finish: Black
- Hanger rod attachment to be welded to the bottom of a beam where large rod sizes and substantial loads exist
- Install in position "A" if rigid hanger rod and vertical adjustment are necessary
- Install in position "B" when a rod attachment is desired, such as Model #40 Eye Rod or #35 Welded Eye Nut
- Based on the allowable stresses shown in ANSI® Code for Pressure Piping
- Conforms with Federal Specification WW-H-171 (Type 22), Manufacturers Standardization Society ANSI/MSS-SP-58 (Type 22); install in accordance with ANSI/MSS-SP-69



Position A

Part Number	RS	A	B	C	Max. Rec. Load (lbs) 650° F
320L0037PL	3/8"	3/4"	2-1/8"	1-9/16"	610
320L0050PL	1/2"	7/8"	2"	1-5/8"	1130
320L0062PL	5/8"	1"	2"	1-5/8"	1810
320L0075PL	3/4"	1-1/4"	1-7/8"	1-7/8"	2710
320L0087PL	7/8"	1-3/8"	2-7/8"	2"	3770
320L0100PL	1"	1-5/8"	2-7/8"	2"	4960
320L0125PL	1-1/4" *	2"	3"	2-1/2"	8000
320L0150PL	1-1/2" *	2-7/16"	4-1/16"	3"	11630
320L0175PL	1-3/4" *	2-5/16"	4-13/16"	3-3/4"	15700
320L0200PL	2" *	3-1/4"	5"	3-3/4"	20700
320L0225PL	2-1/4" *	3-1/2"	6"	4-1/4"	27200
320L0250PL	2-1/2" *	3-3/4"	6"	4-1/2"	33500

*1-1/4" and larger are weldments

Position B

Part Number	RS	A	B	C	Max. Rec. Load (lbs) 650° F
320W0037PL	3/8"	2"	1/2" x 2-1/2"	1-9/16"	610
320W0050PL	1/2"	2"	5/8" x 2-1/2"	1-5/8"	1130
320W0062PL	5/8"	2"	5/8" x 2-3/4"	1-5/8"	1810
320W0075PL	3/4"	2"	7/8" x 4"	1-7/8"	2710
320W0087PL	7/8"	3"	1" x 4"	2"	3770
320W0100PL	1"	3"	1-1/8" x 5"	2"	4960
320W0112PL	1-1/8"	3"	1-1/4" x 5"	2-1/4"	6480
320W0150PL	1-1/2" *	4"	1-5/8" x 5-3/4"	3"	11630
320W0175PL	1-3/4" *	5"	1-7/8" x 6-7/8"	3-3/4"	15700
320W0200PL	2" *	5"	2-1/4" x 6-7/8"	3-3/4"	20700
320W0225PL	2-1/4" *	6"	2-1/2" x 7-3/8"	4-1/4"	27200
320W0250PL	2-1/2" *	6"	2-3/4" x 7-5/8"	4-1/2"	33500

*1-1/4" and larger are weldments

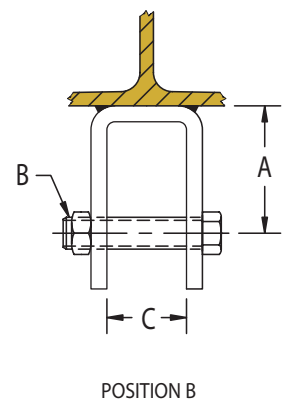
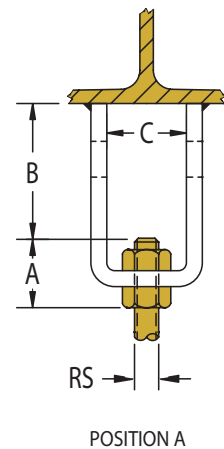

Welded Bracket 348

Light Duty Welded Wall Bracket

- Size Range: Maximum 1/2" rod size
- Surface Finish: Black
- Wall attachment to suspend 2" or smaller static piping



NOTE: Follow fastener manufacturer's recommended shear and pull-out strength when fastening to the structure

Part Number	Size	RS	A	B	C	D	E	Max. Rec. Load (lbs)
3480100PL	1	1/2"	9"	8"	6-1/2"	9/16"	2"	750
3480200PL	2	1/2"	13"	12"	10-1/2"	9/16"	2"	750
3480300PL	3	1/2"	19"	18"	16-1/2"	9/16"	2"	750

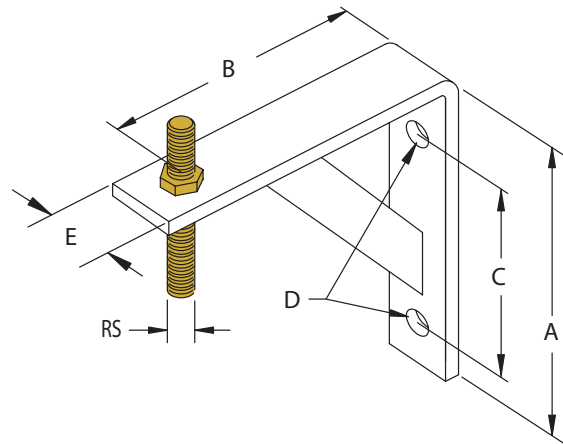

ROD CLIP 350

Threaded Rod Clip for Welded Brackets

- Size Range: 3/8" and 1/2" rod sizes
- Surface Finish: Black
- Allows hanger rod to be adjusted further from or closer to the structural member
- Clip size determined by pipe size

NOTE: If using bracket with clip, slip clip over upper arm of bracket and run a rod through the two plates.

Part Number	Pipe Size	RS	A	B	C
3500037PL	3/4" to 2"	3/8"	3-13/16"	1-3/16"	21/32"
3500050PL	2-1/2" to 3-1/2"	1/2"	4-1/16"	1-7/16"	23/32"

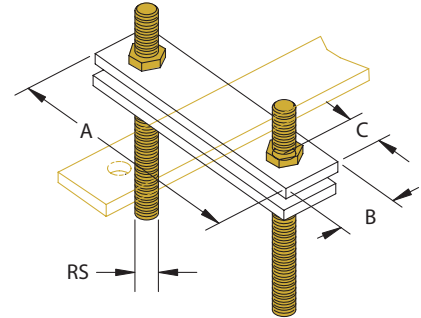
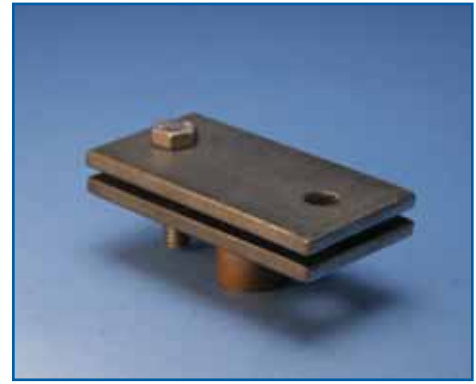

Welded Bracket 351

Light Duty Welded Wall Bracket

- Size Range: Maximum 1/2" rod size
- Surface Finish: Black
- Designed to suspend hanger rod for support of light loads under 750 lbs. and normally used in conjunction with Model #350 Rod Clip
- Determine bracket size by dimension of standard bracket most suitable to the installation

NOTE: Follow fastener manufacturer's recommended shear and pull-out strength when fastening to the structure

Part Number	RS	A	B	C	D	Max. Pipe Size	Max. Rec. Load (lbs)
3510100PL	1/2"	9"	6-1/2"	8"	13/16"	3-1/2"	600
3510200PL	1/2"	13"	10-1/2"	12"	13/16"	3-1/2"	600
3510300PL	1/2"	19"	16-1/2"	18"	13/16"	3-1/2"	600

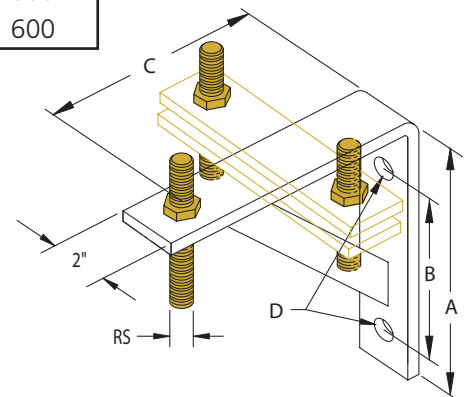

Welded Bracket 352

Medium Duty Welded Wall Bracket

- Surface Finish: Black
- Wall attachment to support or suspend static piping
- Recommended to support loads no greater than 1500 lbs.
- Conforms with Federal Specification WW-H-171 (Type 33), Manufacturers Standardization Society ANSI/MSS-SP-58 (Type 32); install in accordance with ANSI/MSS-SP-69



NOTE: Follow fastener manufacturer's recommended shear and pull-out strength when fastening to the structure

Part Number	Size	A	B	C	D	E	Max. Rec. Load (lbs)
3520100PL	1	18"	15-1/2"	12"	13/16"	4"	1500
3520200PL	2	24"	21-1/2"	18"	13/16"	4-1/2"	1500
3520300PL	3	30"	27-1/2"	24"	13/16"	5"	1500

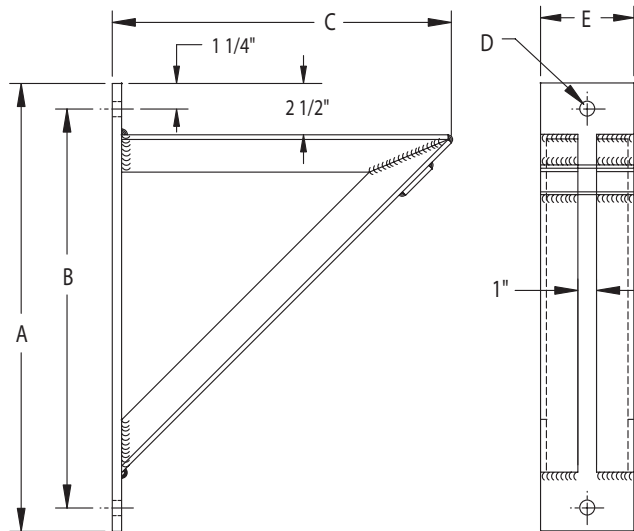

Welded Bracket 353

Heavy Duty Welded Wall Bracket

- Surface Finish: Black
- Wall attachment to support or suspend static piping
- Recommended to support loads no greater than 3000 lbs.
- Conforms with Federal Specification WW-H-171 (Type 34), Manufacturers Standardization Society ANSI/MSS-SP-58 (Type 33); install in accordance with ANSI/MSS-SP-69



NOTE: Follow fastener manufacturer's recommended shear and pull-out strength when fastening to the structure

Part Number	Size	A	B	C	D	E	F	G	Max. Rec. Load (lbs)
3530100PL	1	18"	1-1/2"	7/8"	15-1/4"	12"	13/16"	4"	3000
3530200PL	2	24"	1-3/8"	1"	21-3/8"	18"	15/16"	5"	3000
3530300PL	3	30"	1-1/4"	1-1/8"	27-1/2"	24"	1-1/16"	5"	3000
3530400PL	4	36"	1-1/2"	1-1/2"	33-1/4"	30"	1-1/16"	5"	3000
3530500PL	5	42"	1-1/2"	1-1/2"	39"	36"	1-1/16"	6"	3000
3530600PL	6	50"	2"	1-1/2"	46"	42"	1-1/16"	6"	3000

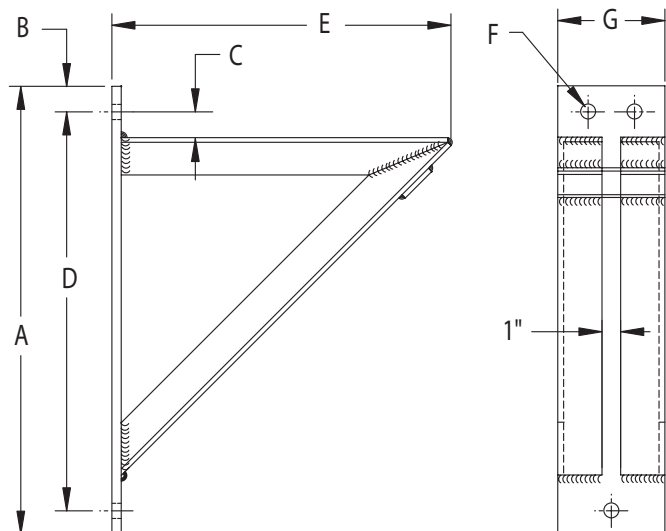

ROD CLIP 4TI/6TI

Hammer-on Rod Clip

- Size Range: 1/4" and 3/8" rod sizes
- Surface Finish: CADDY® COAT Black
- Used to support 1/4" and 3/8" threaded rod from beam flanges 1/8" thru 3/4" thick
- Installation: Hammer over the flange, insert rod, and adjust to desired length



Part Number	Flange Thickness	RS	Finish	Load Limit (lbs.)
4TI24	1/8" - 1/4"	1/4-20	CC Black	200
4TI58	5/16" - 1/2"	1/4-20	CC Black	200
4TI912	9/16" - 3/4"	1/4-20	CC Black	200
6TI24	1/8" - 1/4"	3/8-16	CC Black	200
6TI58	5/16" - 1/2"	3/8-16	CC Black	200
6TI912	9/16" - 3/4"	3/8-16	CC Black	200

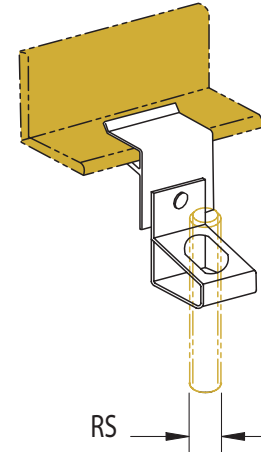

ROD CLIP AF (ANGLED FLANGE)

Hammer-on Z Purlin Rod Clip

- Size Range: 1/4" and 3/8" rod sizes
- Surface Finish: CADDY® COAT Black
- Used to support 1/4" and 3/8" threaded rod from purlin beam flanges 1/16" thru 1/4" thick
- Installation: Hammer-on or install from the floor with the VAFT tool



Part Number	Flange Thickness	RS	Finish	Load Limit (lbs.)
AF144TI	1/16" - 1/4"	1/4-20	CC Black	100
AF146TI	1/16" - 1/4"	3/8-16	CC Black	100

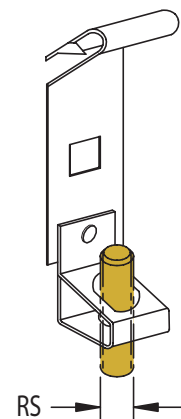

ROD CLIP VF (VERTICAL FLANGE)

Hammer-on C Purlin Rod Clip

- Size Range: 1/4" and 3/8" rod sizes
- Surface Finish: CADDY® COAT Black
- Used to support 1/4" and 3/8" threaded rod from purlin beam flanges 1/16" thru 1/4" thick
- Installation: Hammer-on or install from the floor with the VAFT tool



Part Number	Flange Thickness	RS	Finish	Load Limit (lbs.)
VF144TI	1/16" - 1/4"	1/4-20	CC Black	160
VF146TI	1/16" - 1/4"	3/8-16	CC Black	160

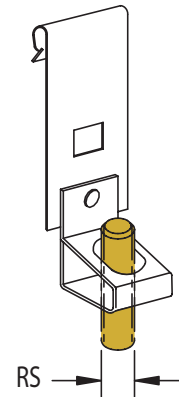

INSTALLATION TOOL VAFT

AF & VF Installation Tool

- Installation tool for VF & AF assemblies
- Used to install the AF or VF rod clips from the floor

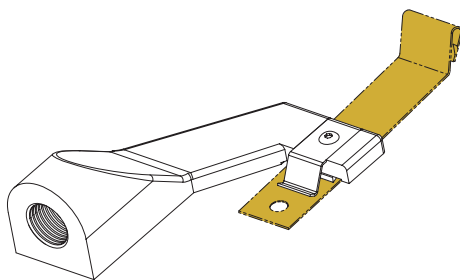



Page 136

605



Page 137

610



Page 138

615



Page 139

617



Page 140

619

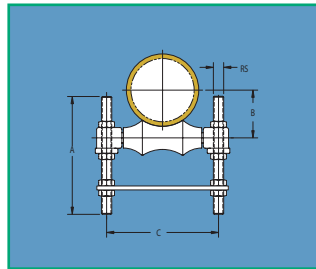

Page 141

620



Page 142-143

ROL12



Page 142-143

ROL13



Page 144

ROL14



Page 145

ROL15



Page 146-147

650



Page 148-149

651



Page 150

721



Page 151

722



Page 152

723



Page 153

724



PIPE ROLLER 605

Two Rod Roller Hanger

- Size Range: 2-1/2" thru 30"
- Surface Finish: Black
- Suspends pipe from two rods where longitudinal movement in pipe may occur due to expansion or contraction
- Conforms with Federal Specification WW-H-171 (Type 42), Manufacturers Standardization Society ANSI/MSS-SP-58 (Type 41); install in accordance with ANSI/MSS-SP-69



NOTE: Roll and sockets are cast iron and axle is carbon steel, available with Electro-zinc plated finish by special order

Part Number	Pipe Size	RS	A	B	C	Max. Rec. Load (lbs)
6050250PL	2-1/2"	1/2"	3-1/4"	4-7/8"	1-13/16"	660
6050300PL	3"	1/2"	3-9/16"	5-5/8"	1-13/16"	700
6050350PL	3-1/2"	1/2"	3-7/8"	6-1/8"	1-13/16"	750
6050400PL	4"	5/8"	4-3/8"	6-11/16"	2-1/4"	750
6050500PL	5"	5/8"	5"	7-15/16"	2-1/4"	750
6050600PL	6"	3/4"	5-13/16"	9-9/16"	2-5/8"	1070
6050800PL	8"	7/8"	7-3/16"	12"	3-1/16"	1350
6051000PL	10"	7/8"	8-7/16"	14"	3-1/16"	1730
6051200PL	12"	7/8"	9-5/8"	15-3/4"	3-3/16"	2400
6051400PL	14"	1"	10-7/8"	17-5/8"	3-1/2"	3130
6051600PL	16"	1"	12"	19-5/16"	3-9/16"	3970
6051800PL	18"	1"	13-1/16"	21-5/8"	3-9/16"	4200
6052000PL	20"	1-1/4"	14-9/16"	24-1/8"	4-5/16"	4550
6052400PL	24"	1-1/2"	17-3/8"	28-3/8"	4-15/16"	6160
6053000PL	30"	1-1/2"	20-15/16"	35-3/8"	5-9/16"	7290

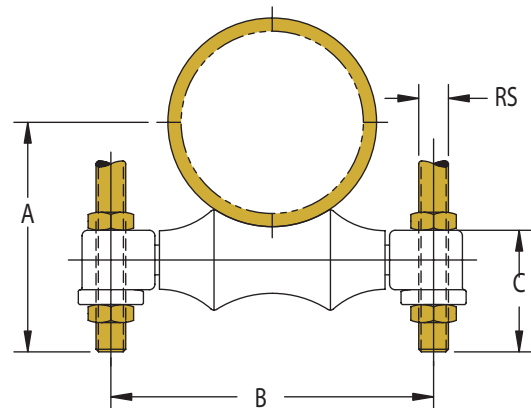

PIPE ROLLER 610

One Rod Roller Hanger

- Size Range: 2-1/2" thru 24"
- Surface Finish: Black
- Suspend pipe from a single hanger rod where longitudinal movement may occur in the pipe due to expansion or contraction
- Conforms with Federal Specification WW-H-171 (Type 44), Manufacturers Standardization Society ANSI/MSS-SP-58 (Type 43); install in accordance with ANSI/MSS-SP-69



NOTE: Yoke and axle are carbon steel and roll is cast iron, available with Electro-zinc plated finish by special order

Part Number	Pipe Size	RS	A	Max. Rec. Load (lbs.)
6010250PL	2-1/2"	1/2"	6-3/8"	225
6100300PL	3"	1/2"	7"	310
6100350PL	3-1/2"	1/2"	7-11/16"	390
6100400PL	4"	5/8"	8-7/16"	475
6100500PL	5"	5/8"	10-3/16"	685
6100600PL	6"	3/4"	11-7/16"	780
6100800PL	8"	7/8"	13-15/16"	780
6101000PL	10"	7/8"	16-3/8"	965
6101200PL	12"	7/8"	18-7/8"	1200
6101400PL	14"	1"	20-7/8"	1200
6101600PL	16"	1"	22-7/16"	1200
6101800PL	18"	1"	25-3/4"	1400
6102000PL	20"	1-1/4"	27"	1600
6102400PL	24"	1-1/4"	32-7/16"	1600

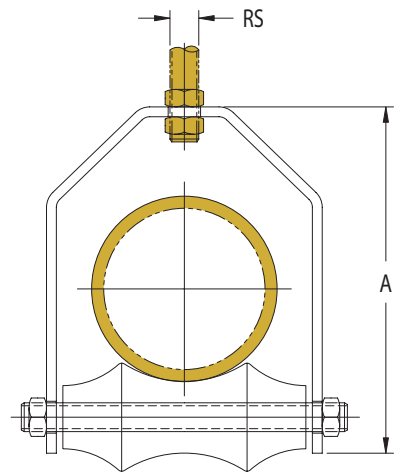

PIPE ROLLER 615

Pipe Roller Support

- Size Range: 2-1/2" thru 24"
- Surface Finish: Black
- Support pipe from a substructure or structural member where longitudinal movement may occur due to expansion or contraction
- Conforms with Federal Specification WW-H-171 (Type 45), Manufacturers Standardization Society ANSI/MSS-SP-58 (Type 44); install in accordance with ANSI/MSS-SP-69



NOTE: Chair and axle are carbon steel and roll is cast iron, available with Electro-zinc plated finish by special order

Part Number	Pipe Size	A	B	C	D	E	Max. Rec. Load (lbs)
6150250PL	2-1/2"	3-1/2"	1-1/4"	4"	1-7/8"	3/8" x 1-1/4"	600
6150300PL	3"	4"	2"	4-5/8"	2-1/4"	3/8" x 1-1/4"	600
6150350PL	3-1/2"	4-5/8"	2"	5-3/8"	2-5/8"	3/8" x 1-1/4"	600
6150400PL	4"	5-3/16"	2"	5-7/8"	2-7/8"	1/2" x 1-1/2"	700
6150500PL	5"	6"	3"	6-15/16"	3-1/2"	1/2" x 1-1/2"	700
6150600PL	6"	6-3/4"	3-1/8"	8"	4"	1/2" x 1-1/2"	1000
6150800PL	8"	8-1/4"	3-3/8"	10"	5-1/4"	5/8" x 1-3/4"	1300
6151000PL	10"	9-15/16"	5-1/4"	12-1/2"	6-5/16"	5/8" x 1-3/4"	1300
6151200PL	12"	11-5/8"	5-1/2"	14"	7-1/2"	5/8" x 1-3/4"	2300
6151400PL	14"	13"	5-3/4"	15-7/8"	8-3/8"	5/8" x 1-3/4"	3000
6151600PL	16"	14-9/16"	8"	17-7/8"	9-7/16"	5/8" x 2"	4000
6151800PL	18"	15-15/16"	9-1/2"	20"	10-7/16"	5/8" x 2"	4000
6152000PL	20"	17-1/8"	10"	22"	11-1/2"	3/4" x 2-1/4"	4000
6152400PL	24"	20-9/16"	12"	26-1/8"	13-15/16"	3/4" x 2-1/4"	4000

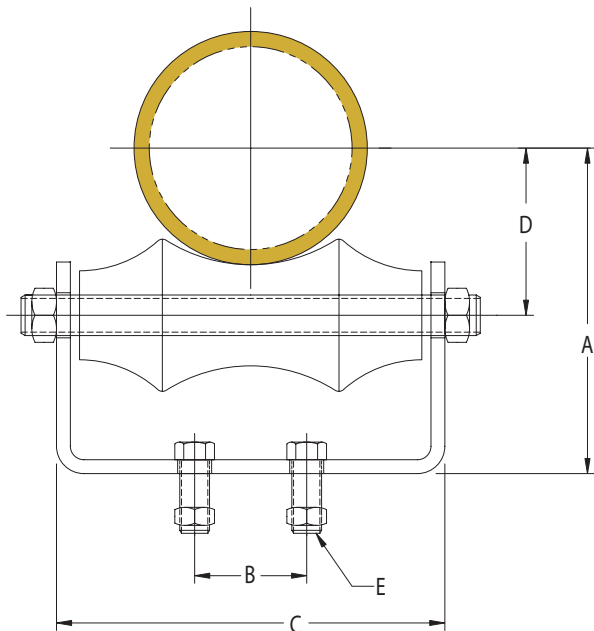

PIPE ROLLER 617

Pipe Roll Stand with Steel Frame

- Size Range: 3-1/2" thru 42"
- Surface Finish: Black
- Support pipe from a substructure or structural member where longitudinal movement may occur due to expansion or contraction
- Conforms with Federal Specification WW-H-171 (Type 45), Manufacturers Standardization Society ANSI/MSS-SP-58 (Type 44); install in accordance with ANSI/MSS-SP-69



NOTE: Frame and axle are carbon steel and roll is cast iron

Part Number	Pipe Size	A	B	C	D	E	Max. Rec. Load (lbs)
6170350PL	3-1/2"	4-3/8"	2-5/8"	4-1/2"	1-1/2"	9/16"	390
6170600PL	6"	6-1/16"	4"	5-3/4"	2-1/4"	9/16"	950
6171000PL	10"	9-13/16"	6-3/8"	8-1/4"	4"	11/16"	2100
6171400PL	14"	12"	8-1/8"	10-9/16"	5-3/4"	13/16"	3075
6172000PL	20"	15-5/8"	11-3/8"	11-3/4"	7"	13/16"	4980
6172400PL	24"	17-3/4"	13-3/8"	12-3/4"	7-5/8"	13/16"	6100
6173000PL	30"	21-7/8"	16-3/4"	16-1/4"	10"	1-1/16"	7500
6174200PL	42"	28-7/8"	23-1/8"	19-1/2"	12"	1-5/16"	12000

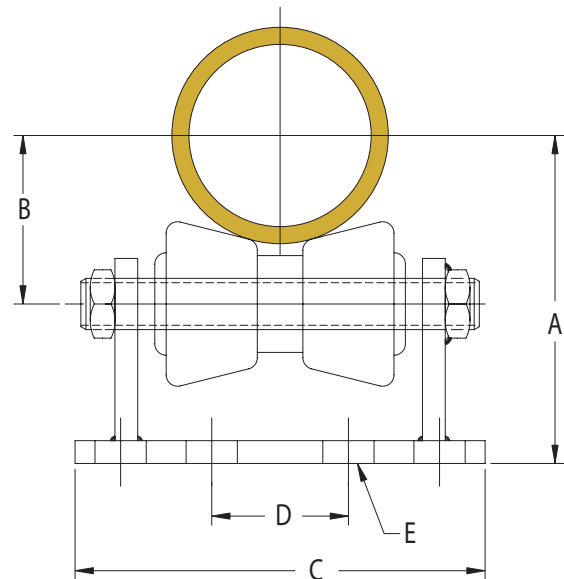

Pipe Roller 619

Adjustable Pipe Roll Stand with Steel Frame

- Size Range: 3-1/2" thru 42"
- Surface Finish: Black
- Support pipe from a substructure or structural member where longitudinal movement may occur due to expansion or contraction
- Vertical adjustment is provided by adjusting bolts on each corner
- Conforms with Federal Specification WW-H-171 (Type 47), Manufacturers Standardization Society ANSI/MSS-SP-58 (Type 46); install in accordance with ANSI/MSS-SP-69



NOTE: Frame and axle are carbon steel and roll is cast iron

Part Number	Pipe Size	A	B	C	D	E	F	Max. Rec. Load (lbs)
6190350PL	3-1/2"	5-1/16"	2-5/8"	5"	1-1/2"	9/16"	1-3/8"	390
6190600PL	6"	6-3/4"	4"	6-1/4"	2-1/4"	9/16"	1-3/8"	950
6191000PL	10"	10-11/16"	6-3/8"	8-3/4"	4"	11/16"	2-1/2"	2100
6191400PL	14"	12-15/16"	8-1/8"	11"	5-3/4"	13/16"	2-7/8"	3075
6192000PL	20"	16-11/16"	11-3/8"	12-1/4"	7"	13/16"	3-1/8"	4980
6192400PL	24"	18-13/16"	13-3/8"	13-1/4"	7-5/8"	13/16"	3-1/8"	6100
6193000PL	30"	23-1/16"	16-3/4"	16-3/4"	10"	1-1/16"	3-7/8"	7500
6194200PL	42"	30-1/4"	23-1/8"	20"	12"	1-5/16"	4-1/2"	12000

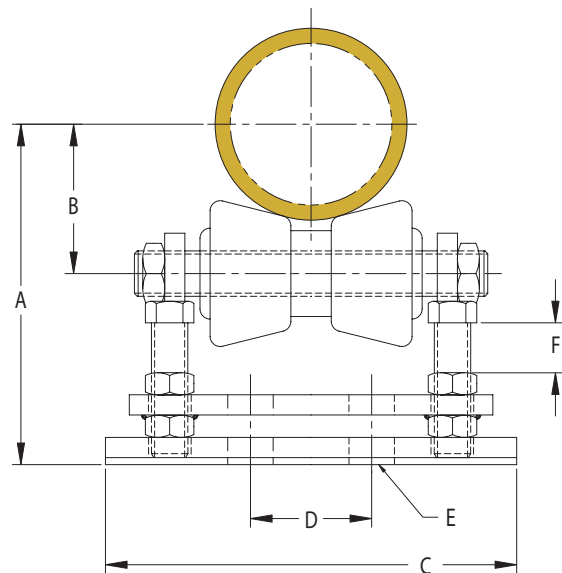

PIPE ROLLER 620

Adjustable Pipe Roll Support

- Size Range: 2-1/2" thru 30"
- Surface Finish: Black
- Support pipe from a substructure or structural member where longitudinal movement may occur due to expansion or contraction and where vertical adjustment of up to 6" may be necessary
- Conforms with Federal Specification WW-H-171 (Type 42), Manufacturers Standardization Society ANSI/MSS-SP-58 (Type 41); install in accordance with ANSI/MSS-SP-69

NOTE: Roll and sockets are cast iron and axle is carbon steel, available with Electro-zinc plated finish by special order

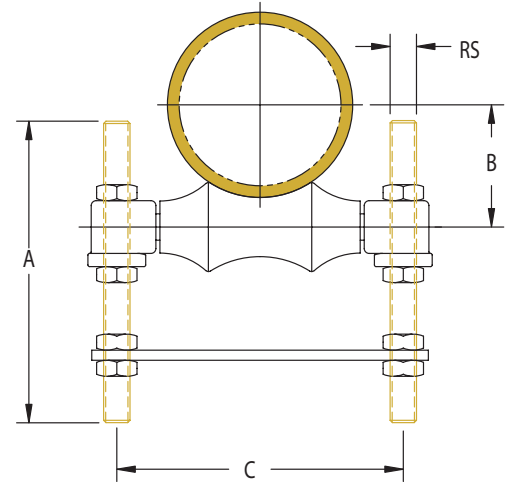

Part Number	Pipe Size	RS	A	B	C	Max. Rec. Load (lbs)
6200250PL	2-1/2"	1/2"	12"	1-7/8"	4-7/8"	660
6200300PL	3"	1/2"	12"	2-1/4"	5-5/8"	700
6200350PL	3-1/2"	1/2"	12"	2-5/8"	6-1/8"	750
6200400PL	4"	5/8"	12"	2-7/8"	6-11/16"	750
6200500PL	5"	5/8"	12"	3-1/2"	7-15/16"	750
6200600PL	6"	3/4"	12"	4"	9-9/16"	1070
6200800PL	8"	7/8"	12"	5-1/4"	12"	1350
6201000PL	10"	7/8"	12"	6-5/16"	14"	1730
6201200PL	12"	7/8"	12"	7-7/16"	15-3/4"	2400
6201400PL	14"	1"	12"	8-3/8"	17-5/8"	3130
6201600PL	16"	1"	18"	9-7/16"	19-5/16"	3970
6201800PL	18"	1"	18"	10-7/16"	21-5/8"	4200
6202000PL	20"	1-1/4"	18"	11-1/2"	24-1/8"	4550
6202400PL	24"	1-1/2"	24"	13-15/16"	28-3/8"	6060
6203000PL	30"	1-1/2"	24"	17-1/4"	35-3/8"	7290



Strut Pipe Roller ROL12

Pipe Roller for 1" thru 4" Pipe

- Size Range: 1" thru 4" pipe
- Surface Finish: Electro-zinc plated
- Pipe rollers which mount to strut for applications where there is longitudinal pipe movement

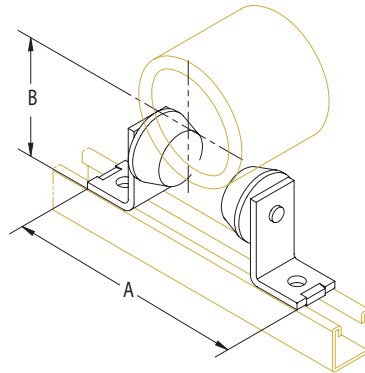

See chart on page 143

Strut Pipe Roller ROL13

Pipe Roller for 4" thru 8" Pipe

- Size Range: 4" thru 8" pipe
- Surface Finish: Electro-zinc plated
- Pipe rollers which mount to strut for applications where there is longitudinal pipe movement

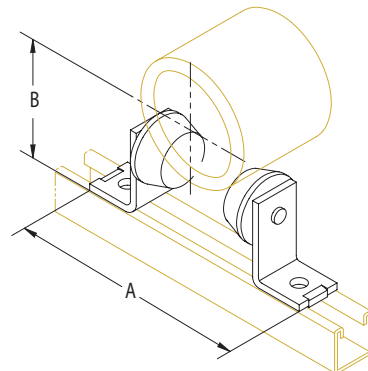

See chart on page 143

Fitting specifications for strut-mounted rollers ROL12-ROL15 (unless noted otherwise):

- Hole Sizes: $9/16"$, Spacing $13/16"$ from edge and $1-7/8"$ on center
- Width: $1-5/8"$
- Thickness $1/4"$
- Surface Finish: Electro-zinc plated



ROL12 & ROL13 Sizing Chart						
Pipe Size	Saddle Number	Actual Covering Thickness	Actual O.D.	Actual Radius	A	B
3/4	None	0"	11/16"	17/32"	6-1/2"	2-15/16"
	630	7/8"	3-1/4"	1-5/8"	6-1/2"	4-1/8"
	631	1-7/16"	4-3/8"	2-3/16"	8-1/4"	4-7/16"
	632	1-7/8"	5-1/16"	2-17/32"	8-1/4"	4-13/16"
1	None	0"	15/16"	21/32"	6-1/2"	3-1/8"
	630	11/16"	3-5/8"	1-13/16"	7-1/4"	4-1/4"
	631	1-9/16"	4-5/8"	2-5/16"	8-1/4"	4-9/16"
	632	2-1/8"	5-3/4"	2-7/8"	8-1/4"	5-1/8"
1-1/4	None	0"	1-11/16"	27/32"	6-1/2"	3-5/16"
	630	7/8"	3-7/8"	1-15/16"	7-1/4"	4-5/16"
	631	1-5/8"	5-1/8"	2-9/16"	8-1/4"	4-13/16"
	632	1-15/16"	6"	3"	8-1/4"	5-1/4"
	633	2-7/16"	6-7/8"	3-7/16"	9-1/4"	5-5/8"
	634					
1-1/2	None	0"	1-7/8"	15/16"	6-1/2"	3-3/8"
	630	1"	4-1/4"	2-1/8"	8-1/4"	4-3/8"
	631	1-1/2"	5-1/4"	2-5/8"	8-1/4"	4-7/8"
	632	2-5/16"	6-7/8"	3-7/16"	9-1/4"	5-9/16"
	633	2-13/16"	7-3/4"	3-7/8"	9-1/4"	6"
2	None	0"	2-3/8"	1-3/16"	6-1/2"	3-11/16"
	630	1-1/16"	4-3/4"	2-3/8"	8-1/4"	4-5/8"
	631	1-9/16"	5-3/4"	2-7/8"	8-1/4"	5-1/8"
	632	2-1/8"	7-1/8"	3-9/16"	9-1/4"	5-11/16"
	633	2-5/8"	8-1/8"	4-1/16"	10-1/8"	6-1/16"
	634	3-1/8"	9-1/8"	4-9/16"	10-1/8"	6-5/8"
2-1/2	None	0"	2-7/8"	1-7/16"	6-1/2"	3-15/16"
	630	1-1/16"	5-3/8"	2-11/16"	8-1/4"	4-15/16"
	631	1-7/16"	6-1/8"	3-1/16"	9-1/4"	5-1/4"
	632	2-5/16"	7-7/8"	3-15/16"	9-1/4"	6-1/8"
	633	2-7/8"	9"	4-1/2"	9-1/4"	6-3/4"
	634	3-3/8"	10"	5"	9-1/4"	7-1/4"
3	None	0"	3-1/2"	1-3/4"	7-1/4"	4-1/8"
	630	1"	5-7/8"	2-15/16"	8-1/4"	5-1/4"
	631	1-9/16"	7"	3-1/2"	9-1/4"	5-5/8"
	632	2-1/16"	8"	4"	10-1/8"	6-1/16"
	633	2-9/16"	9"	4-1/2"	10-1/8"	6-5/8"
	634	3-1/16"	10"	5"	10-7/8"	7"
3-1/2	None	0"	4"	2"	7-1/4"	4-3/8"
	630	1-1/4"	6-7/8"	3-7/16"	9-1/4"	5-1/2"
	631	1-13/16"	8"	4"	9-1/4"	6-1/8"
	632	2-1/4"	8-7/8"	4-7/16"	10-1/8"	6-9/16"
	633	2-3/4"	9-7/8"	4-15/16"	10-1/8"	7"
	634	3-5/16"	11"	5-1/2"	10-7/8"	7-7/16"
4	None	0"	4-1/2"	2-1/4"	8-1/4"	4-1/2"
	630	1-1/16"	7-1/8"	3-9/16"	9-1/4"	5-11/16"
	631	1-9/16"	8-1/8"	4-1/16"	10-1/8"	6-1/16"
	632	2-1/16"	9-1/8"	4-9/16"	10-1/8"	6-5/8"
	633	2-9/16"	10"	5"	10-1/8"	7-1/16"
	634	3-1/16"	11-1/4"	5-5/8"	10-7/8"	7-5/8"
5	635	4-1/16"	13"	6-1/2"	10-7/8"	8-9/16"
	None	0"	5-5/8"	2-13/16"	8-1/4"	5-1/16"
	630	1"	8-1/4"	4-1/8"	10-1/8"	6-1/8"
	631	1-1/2"	9-3/8"	4-11/16"	10-1/8"	6-11/16"
	632	2"	10-3/8"	5-3/16"	10-7/8"	7"
	633	2-9/16"	11-1/4"	5-5/8"	10-7/8"	7-5/8"
6	634	3-1/16"	12-3/8"	6-3/16"	10-7/8"	8-1/8"
	635	4-3/16"	14-1/4"	7-1/8"	10-7/8"	9-3/16"
	None	0"	6-5/8"	3-5/16"	9-1/4"	5-7/16"
	630	1"	9"	4-1/2"	10-1/8"	6-9/16"
	631	1-1/2"	10-1/8"	5-1/16"	10-7/8"	7"
	632	2"	11"	5-1/2"	10-7/8"	7-1/2"
8	633	2-1/2"	12-3/8"	6-3/16"	10-7/8"	8-3/16"
	634	3"	13-1/2"	6-3/4"	10-7/8"	8-5/8"
	635	4-1/8"	15-1/8"	7-9/16"	10-7/8"	9-11/16"
	None	0"	8-5/8"	4-5/16"	10-1/8"	6-3/8"
	631	1-1/2"	12"	6"	10-7/8"	8"
8	632	2"	13"	6-1/2"	10-7/8"	8-9/16"
	633	2-11/16"	14-1/2"	7-1/4"	10-7/8"	9-5/16"
	634	3-1/8"	15-3/8"	7-11/16"	10-7/8"	9-13/16"
	635	4-1/8"	17-3/8"	8-11/16"	10-7/8"	10-7/8"



Strut Pipe Roller ROL14

Pipe Roller for 6" thru 16" Pipe

- Size Range: 6" thru 16" pipe
- Surface Finish: Electro-zinc plated
- Pipe rollers which mount to strut for applications where there is longitudinal pipe movement

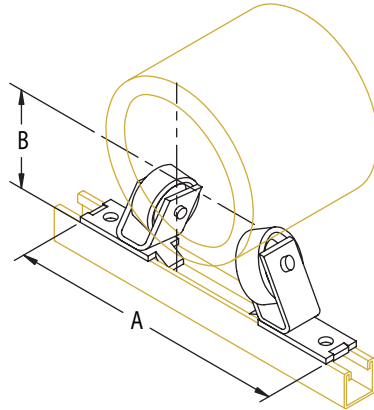

ROL14 Sizing Chart

Pipe Size	Saddle Number	Actual Covering Thickness	Actual O.D.	Actual Radius	A	B
6	None	0"	6-5/8"	3-5/16"	9-9/16"	6-7/8"
	630	1"	9"	4-1/8"	10-3/16"	7-7/8"
	631	1-1/2"	10"	5"	10-5/8"	8-3/8"
	632	2"	11"	5-1/2"	11"	8-7/8"
	633	2-1/2"	12"	6"	11-3/8"	9-3/8"
	634	3"	13"	6-1/2"	11-3/4"	9-7/8"
	635	4-1/8"	15-1/4"	7-5/8"	12-1/2"	10-15/16"
8	None	0"	8-5/8"	4-5/16"	10-1/4"	7-13/16"
	631	1-1/2"	12"	6"	11-3/8"	9-3/8"
	632	2"	13"	6-1/2"	11-3/4"	9-7/8"
	633	2-11/16"	14-3/8"	7-3/16"	12-3/16"	10-7/16"
	634	3-1/8"	15-1/4"	7-5/8"	12-1/2"	10-15/16"
	635	4-1/8"	17-1/4"	8-5/8"	13-1/4"	11-7/8"
	None	0"	10-3/4"	5-3/8"	11"	8-13/16"
10	631	1-1/2"	14-1/4"	7-1/8"	12-1/8"	10-7/16"
	632	2-1/16"	15-1/4"	7-5/8"	12-1/2"	10-15/16"
	633	2-9/16"	16-1/4"	8-1/8"	12-13/16"	11-3/8"
	634	3-1/16"	17-1/4"	8-5/8"	13-1/8"	11-7/8"
	635	4-1/16"	19-1/4"	9-3/4"	13-7/8"	12-13/16"
	None	0"	12-3/4"	6-3/8"	11-11/16"	9-3/4"
	12	631	1-9/16"	16-1/8"	8-1/16"	12-7/8"
632		2-1/16"	17-1/4"	8-5/8"	13-1/4"	11-7/8"
633		2-5/8"	18-1/4"	9-1/8"	13-9/16"	12-5/16"
634		3-1/16"	19-1/4"	9-5/8"	13-7/8"	12-13/16"
635		4-1/8"	21-3/8"	10-11/16"	14-5/8"	13-3/4"
None		0"	14"	7"	12-1/16"	10-5/16"
14		631	1-1/2"	17-1/2"	8-3/4"	13-3/16"
	632	2"	18-3/8"	9-3/16"	13-9/16"	12-5/16"
	633	2-1/2"	19-3/8"	9-11/16"	13-7/8"	12-13/16"
	634	3"	20-3/8"	10-3/16"	14-1/4"	13-1/4"
	635	4"	22-3/8"	11-3/16"	14-7/8"	14-1/4"
	None	0"	16"	8"	12-3/4"	11-5/16"
	16	631	1-1/2"	19-5/8"	9-13/16"	13-7/8"
632		2"	20-3/8"	10-3/16"	14-13/16"	13-1/4"
633		2-1/2"	21-5/8"	10-13/16"	14-1/2"	13-3/4"
634		3"	22-1/8"	11-1/16"	14-7/8"	14-1/4"
635		4"	24-3/8"	12-3/16"	15-1/2"	15-1/8"



Strut Pipe Roller ROL15

Pipe Roller for 16" thru 24" Pipe

- Size Range: 16" thru 24" pipe
- Surface Finish: Electro-zinc plated
- Pipe rollers which mount to strut for applications where there is longitudinal pipe movement

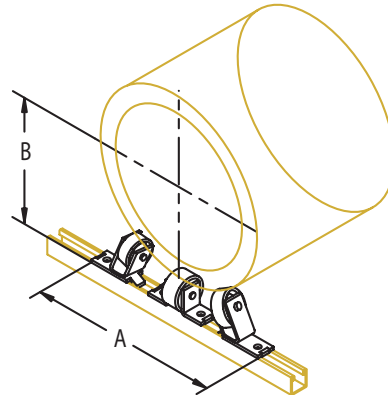

ROL15 Sizing Chart

Pipe Size	Saddle Number	Actual Covering Thickness	Actual O.D.	Actual Radius	A	B
18	None	0"	18"	9"	15-1/2"	11-7/8"
	631	1-1/2"	21-3/8"	10-11/16"	16-3/16"	13-7/16"
	632	2"	22-3/8"	11-3/16"	16-3/8"	13-15/16"
	633	2-1/2"	23-3/8"	11-11/16"	16-9/16"	14-7/16"
	634	3"	24-3/8"	12-3/16"	16-3/4"	14-15/16"
	635	4"	26-3/8"	13-3/16"	17-3/16"	15-15/16"
20	None	0"	20"	10"	16"	12-3/16"
	631	1-1/2"	23-3/8"	11-11/16"	16-9/16"	14-7/16"
	632	2"	24-3/8"	12-3/16"	16-7/8"	14-7/8"
	633	2-1/2"	25-3/8"	12-11/16"	16-15/16"	15-7/16"
	634	3"	26-3/8"	13-3/16"	17-3/16"	15-7/8"
	635	4"	28-3/8"	14-3/16"	17-1/2"	16-15/16"
24	None	0"	24"	12"	16-13/16"	14-13/16"
	631	1-1/2"	27-1/2"	13-3/4"	17-1/2"	16-3/8"
	632	2"	28-1/2"	14-1/4"	17-1/2"	16-7/8"
	633	2-1/2"	29-1/2"	14-3/4"	17-11/16"	17-3/8"
	634	3"	30-1/2"	15-1/4"	17-7/8"	17-7/8"
	635	4"	32-1/2"	16-1/4"	18-1/8"	18-7/8"
30	special order	0"	30"	15"	17-13/16"	17-13/16"



PIPE GUIDE 650

Pipe Alignment Guide

- Size Range: 1/2" thru 24"
- Surface Finish: Painted, color may vary
- Maintaining pipe alignment during longitudinal expansion or contraction cycles of hot systems
- Available in HD finish by special order, when ordering must specify:
 1. Pipe Size
 2. Insulation Thickness

NOTE:

1. Pipe alignment guides are not designed to be load bearing
2. Maximum Pipe Movement:
 - 1" thru 6" pipe: 6" movement
 - 8" thru 16" pipe: 8" movement
 - 18" thru 24" pipe: 10" movement
3. Use minimum of two guides per run and locate first guide 4" pipe diameters from expansion joint or loop
4. One half of internal "spider" pipe clamp assembly remains inside guide housing at installation. Protruding portion of clamp assembly must be toward anchored end of pipe or toward direction from which pipe movement will occur
5. Special guides with longer travels are available upon request

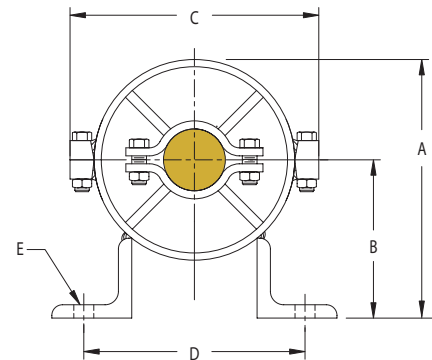
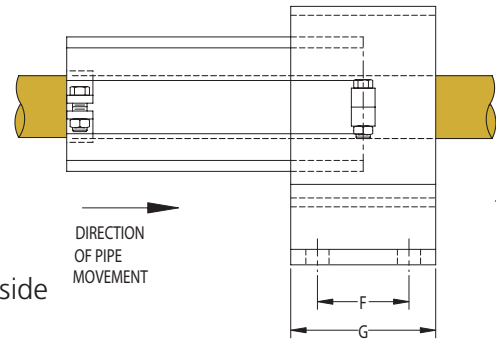
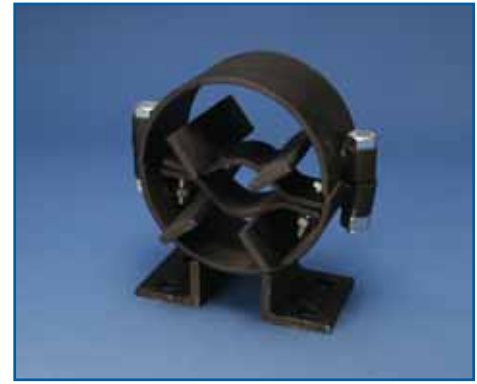

INSULATION NOT INCLUDED

GUIDE SIZE SELECTION CHART

Pipe Size	Insulation Thickness						
	1"	1-1/2"	2"	2-1/2"	3"	3-1/2"	4"
1/2"	1	1	2	3	4	4	5
3/4"	1	2	3	4	4	5	5
1"	1	2	3	4	4	5	5
1-1/4"	1	2	3	4	4	5	5
1-1/2"	2	2	3	4	4	5	5
2"	2	3	4	4	5	5	6
2-1/2"	3	3	4	4	5	5	6
3"	3	4	4	5	5	6	6
4"	4	4	5	5	6	6	7
5"	5	5	5	6	6	7	8
6"	5	5	6	6	7	8	8
8"	6	6	7	8	8	9	9
10"	8	8	8	9	9	10	10
12"	9	9	9	10	10	11	12
14"	10	10	10	10	11	11	12
16"	11	11	11	11	12	12	13
18"	12	12	12	12	13	13	14
20"	13	13	13	13	14	14	14
**24"	14	14	14	14	-	-	-

** Max. 2-1/2" insulation



PIPE GUIDE 650 (Cont.)

Part Number*	Guide Size	A	B	C	D	E	F	G	Max. Allowable Movement
6500100'XX'PT	1	5-3/4"	3-1/2"	6-1/8"	4-1/4"	5/8"	1-3/4"	3"	6"
6500200'XX'PT	2	6-3/4"	4"	7-1/8"	4-1/2"	5/8"	1-3/4"	3"	6"
6500300'XX'PT	3	7-5/8"	4-3/8"	8-1/8"	5-1/4"	5/8"	1-3/4"	3"	6"
6500400'XX'PT	4	9-1/2"	5-1/4"	10-1/8"	6-1/4"	5/8"	1-3/4"	3"	6"
6500500'XX'PT	5	11-3/4"	6-1/4"	12-1/8"	7-1/4"	5/8"	2-3/4"	4"	6"
6500600'XX'PT	6	13-3/8"	7-1/4"	14-1/8"	8-1/4"	5/8"	2-3/4"	4"	6"
6500700'XX'PT	7	15"	8"	16-1/8"	10"	3/4"	4"	6"	8"
6500800'XX'PT	8	17"	9"	18-1/8"	11"	3/4"	4"	6"	8"
6500900'XX'PT	9	18-3/4"	9-3/4"	20-1/8"	12"	3/4"	4"	6"	8"
6501000'XX'PT	10	21-1/8"	11-1/8"	22-1/8"	13-1/2"	7/8"	6"	8"	8"
6501100'XX'PT	11	23-1/8"	12-1/8"	24-1/8"	14-1/2"	7/8"	6"	8"	8"
6501200'XX'PT	12	25"	13"	26-1/8"	15-1/2"	7/8"	6"	8"	8"
6501300'XX'PT	13	27-3/4"	14-3/4"	28-1/8"	17-1/2"	1-1/8"	6"	8"	10"
6501400'XX'PT	14	31-1/2"	16-1/2"	32-1/8"	19-1/2"	1-1/8"	6"	8"	10"

*'XX' in part number indicates insulation thickness:

- 10 = 1" insulation
- 15 = 1-1/2" insulation
- 20 = 2" insulation
- 25 = 2-1/2" insulation
- 30 = 3" insulation
- 35 = 3-1/2" insulation
- 40 = 4" insulation



PIPE GUIDE 651

Pre-Insulated Pipe Alignment Guide

- Size Range: 1/2" thru 18"
- Surface Finish: Painted, color may vary
- Maintaining pipe alignment during longitudinal expansion or contraction cycles of vapor barrier covered insulated pipe
- Carbon steel with painted finish, calcium silicate insulation

NOTE:

1. Pipe alignment guides are not designed to be load bearing
2. Maximum Pipe Movement:
 - 1" thru 6" pipe: 6" movement
 - 8" thru 16" pipe: 8" movement
 - 18" thru 24" pipe: 10" movement
3. Use minimum of two guides per run and locate first guide 4 pipe diameters from expansion joint or loop
4. One half of internal "spider" pipe clamp assembly remains inside guide housing at installation. Protruding portion of clamp assembly must be toward anchored end of pipe or toward direction from which pipe movement will occur
5. Special guides with longer travels are available upon request

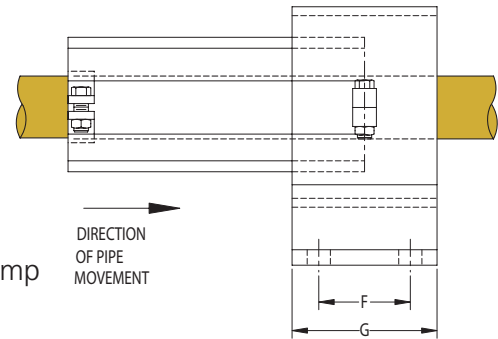

GUIDE SIZE SELECTION CHART

Pipe Size	Insulation Thickness					
	1-1/2"	2"	2-1/2"	3"	3-1/2"	4"
1/2"	1	2	2	3	3	4
3/4"	1	2	2	3	3	4
1"	1	2	2	3	3	4
1-1/4"	2	2	3	3	4	4
1-1/2"	2	2	3	3	4	4
2"	2	3	3	4	4	4
2-1/2"	2	2	2	4	4	5
3"	3	3	4	4	5	5
4"	3	4	4	5	5	6
5"	4	4	5	5	6	6
6"	4	5	5	6	6	7
8"	5	6	6	7	7	8
10"	7	7	7	8	8	9
12"	8	8	8	9	9	10
14"	8	9	9	10	10	11
16"	9	10	10	11	11	12
18"	10	11	11	12	12	12

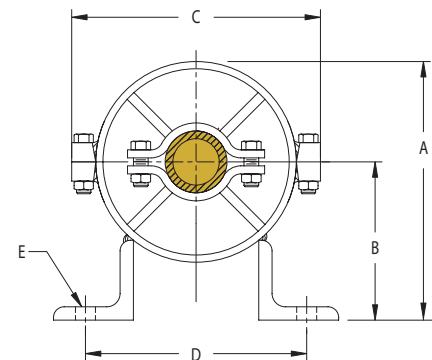

PIPE GUIDE 651 (Cont.)

Part Number*	Guide Size	A	B	C	D	E	F	G	Max. Allowable Movement
6510100'XX'PT	1	7-5/8"	4-3/8"	8"	5-1/2"	5/8"	1-3/4"	3"	6"
6510200'XX'PT	2	9-1/2"	5-1/4"	10-3/8"	6-1/4"	5/8"	1-3/4"	3"	6"
6510300'XX'PT	3	11-5/8"	6-1/4"	12-1/2"	7-1/4"	5/8"	2-3/4"	4"	6"
6510400'XX'PT	4	13-5/8"	7-1/4"	14-1/2"	8-1/4"	5/8"	2-3/4"	4"	6"
6510500'XX'PT	5	15"	8"	15-3/4"	10"	3/4"	4"	6"	6"
6510600'XX'PT	6	17"	9"	17-3/4"	11"	3/4"	4"	6"	8"
6510700'XX'PT	7	18-3/4"	9-3/4"	20-1/8"	12"	3/4"	4"	6"	8"
6510800'XX'PT	8	21-1/8"	11-1/8"	22-1/8"	13-1/2"	3/4"	4"	6"	8"
6510900'XX'PT	9	23-1/2"	12-1/8"	24-1/8"	14-1/2"	7/8"	6"	8"	8"
6511000'XX'PT	10	25"	13"	26-5/8"	15-1/2"	7/8"	6"	8"	8"
6511100'XX'PT	11	27-3/4"	14-3/4"	28-5/8"	17-1/2"	1-1/8"	6"	8"	8"
6511200'XX'PT	12	31-1/2"	16-1/2"	32-5/8"	19-1/2"	1-1/8"	6"	8"	10"

*'XX' in part number indicates insulation thickness:

- 10 = 1" insulation
- 15 = 1-1/2" insulation
- 20 = 2" insulation
- 25 = 2-1/2" insulation
- 30 = 3" insulation
- 35 = 3-1/2" insulation
- 40 = 4" insulation



PIPE SUPPORT 721

Saddle Support with U-bolt

- Size Range: 2-1/2" thru 36"
- Surface Finish: Black
- Stanchion type support where vertical adjustment is not needed
- U-bolt provides additional stability
- Conforms with Federal Specification WW-H-171 (Type 37, 38), Manufacturers Standardization Society ANSI/MSS-SP-58 (Type 37); install in accordance with ANSI/MSS-SP-69



NOTE: Base not included

Part Number	Pipe Size	A	B	C (NPS)
7210250PL	2-1/2"	3-1/8"	4"	1-1/2"
7210300PL	3"	3-7/16"	4"	1-1/2"
7210400PL	4"	4-1/4"	4"	2-1/2"
7210500PL	5"	4-9/16"	4"	2-1/2"
7210600PL	6"	5-1/2"	4"	2-1/2"
7210800PL	8"	7"	4"	2-1/2"
7211000PL	10"	8"	4"	2-1/2"
7211200PL	12"	9-3/16"	4"	2-1/2"
7211400PL	14"	10-9/16"	4"	3"
7211600PL	16"	11-9/16"	4"	3"
7211800PL	18"	13-9/16"	4"	4"
7212000PL	20"	14-9/16"	4"	4"
7212400PL	24"	16-9/16"	4"	4"
7212600PL	26"	17-9/16"	4"	4"
7213000PL	30"	20-11/16"	4"	4"
7213200PL	32"	21-11/16"	4"	4"
7213600PL	36"	23-11/16"	4"	4"

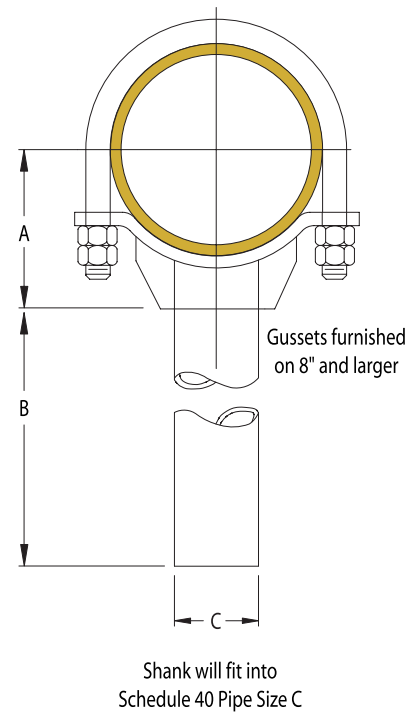

PIPE SUPPORT 722

Adjustable Pipe Support

- Size Range: 4", 6", 8", and 10"
- Surface Finish: Black
- N.P.T. pipe welded to pipe saddle with a N.P.T. pipe lock nut allowing for vertical adjustment in the pipe stanchion
- Conforms with Federal Specification WW-H-171 (Type 39), Manufacturers Standardization Society ANSI/MSS-SP-58 (Type 38); install in accordance with ANSI/MSS-SP-69



Part Number	Pipe Size	A
7220400PL	4"	10-5/8"
7220600PL	6"	11-11/16"
7220800PL	8"	12-11/16"
7221000PL	10"	13-3/4"

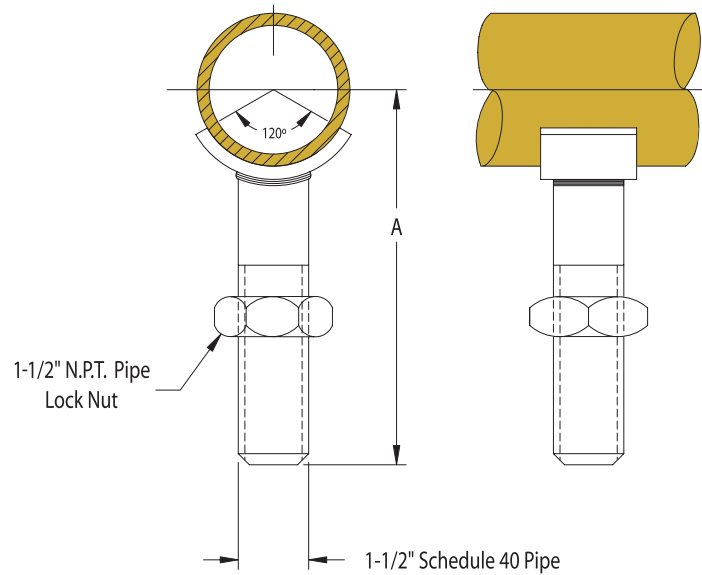

PIPE SUPPORT 723

Adjustable Pipe Support Assembly

- Size Range: 2-1/2" thru 36"
- Surface Finish: Black
- Supports horizontal pipe from stanchions where vertical adjustment is needed
- Conforms with Federal Specification WW-H-171 (Type 38, 39), Manufacturers Standardization Society ANSI/MSS-SP-58 (Type 38); install in accordance with ANSI/MSS-SP-69



Part Number	Pipe Size	RS	A	Adjustment B	
				Min.	Max.
7230250PL	2-1/2"	1-1/2"	2-11/16"	7-15/16"	12-7/16"
7230300PL	3"	1-1/2"	2-7/8"	8-1/8"	12-5/8"
7230350PL	3-1/2"	1-1/2"	3-1/8"	8-3/8"	12-7/8"
7230400PL	4"	2-1/2"	3-3/4"	9-7/16"	13-15/16"
7230500PL	5"	2-1/2"	4-1/16"	9-3/4"	14-1/4"
7230600PL	6"	2-1/2"	4-3/4"	10-7/16"	14-15/16"
7230800PL	8"	2-1/2"	6-11/16"	12-3/8"	16-7/8"
7231000PL	10"	2-1/2"	7-3/4"	13-7/16"	17-15/16"
7231200PL	12"	2-1/2"	8-3/4"	14-7/16"	18-15/16"
7231400PL	14"	3"	10-3/4"	18-3/16"	22-11/16"
7231600PL	16"	3"	11-3/4"	19-3/16"	23-11/16"
7231800PL	18"	4"	13-1/2"	21-1/2"	26"
7232000PL	20"	4"	14-1/2"	22-1/2"	27"
7232400PL	24"	4"	17-3/4"	25-3/4"	30-1/4"
7232600PL	26"	4"	18-3/4"	26-3/4"	31-1/4"
7233000PL	30"	4"	20-7/8"	28-7/8"	33-7/8"
7233200PL	32"	4"	21-7/8"	29-7/8"	34-7/8"
7233600PL	36"	4"	23-7/8"	31-7/8"	36-3/8"

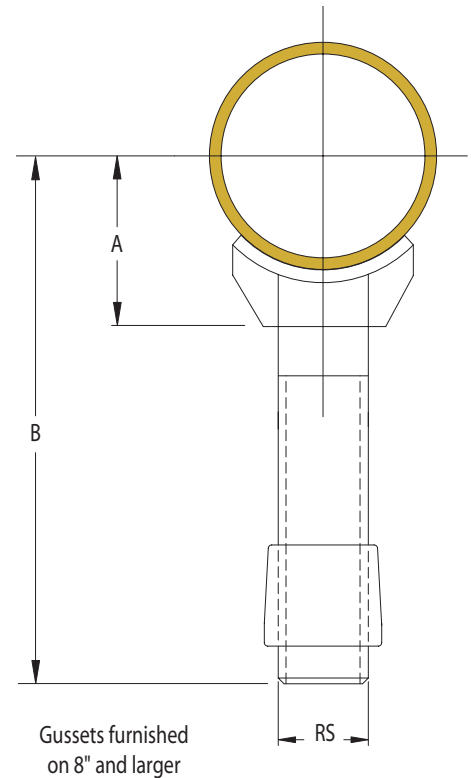

PIPE SUPPORT 724

Adjustable Pipe Support Assembly with U-bolt

- Size Range: 2-1/2" thru 36"
- Surface Finish: Black
- Supports horizontal pipe from stanchions where vertical adjustment is needed
- Conforms with Federal Specification WW-H-171 (Type 38, 39), Manufacturers Standardization Society ANSI/MSS-SP-58 (Type 37, 38); install in accordance with ANSI/MSS-SP-69



Part Number	Part Size	RS	A	Adjustment B	
				Min.	Max.
7240250PL	2-1/2"	1-1/2"	3-1/8"	8-3/8"	12-7/8"
7240300PL	3"	1-1/2"	3-7/16"	8-11/16"	13-3/16"
7240350PL	3-1/2"	1-1/2"	3-11/16"	8-15/16"	13-7/16"
7240400PL	4"	2-1/2"	4-1/4"	9-15/16"	14-7/16"
7240500PL	5"	2-1/2"	4-9/16"	10-1/4"	14-3/4"
7240600PL	6"	2-1/2"	5-1/2"	11-3/16"	15-11/16"
7240800PL	8"	2-1/2"	7"	12-11/16"	17-3/16"
7241000PL	10"	2-1/2"	8"	13-11/16"	18-3/16"
7241200PL	12"	2-1/2"	9-3/16"	14-7/8"	19-3/8"
7241400PL	14"	3"	10-9/16"	18"	22-1/2"
7241600PL	16"	3"	11-9/16"	19"	23-1/2"
7241800PL	18"	4"	13-9/16"	21-9/16"	26-1/16"
7242000PL	20"	4"	14-9/16"	22-9/16"	27-1/16"
7242400PL	24"	4"	16-9/16"	24-9/16"	29-1/16"
7242600PL	26"	4"	17-9/16"	25-9/16"	30-1/16"
7243000PL	30"	4"	20-11/16"	28-11/16"	33-3/16"
7243200PL	32"	4"	21-11/16"	29-11/16"	34-3/16"
7243600PL	36"	4"	23-1/16"	31-11/16"	36-3/16"

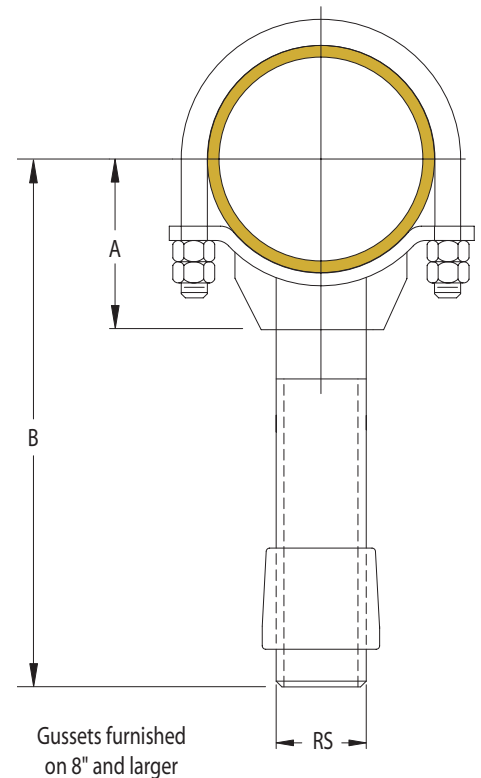

CADDY®

READY. SET. INSTALL.

The CADDY® SPEED LINK universal support system is a time-saving, cost-effective alternative to jack chain, threaded rod and associated hardware. A crimped-on hook at one end allows the wire rope to be quickly looped around a beam, hooked onto a fastener or attached to the suspended load. CADDY SPEED LINK meets the fire rating requirements for DIN 4102-2 for 30 minutes at 30 percent of rated load.

CADDY SPEED LINK's unique locking device ensures stability and allows for adjustment both during and after installation. CADDY SPEED LINK is available in 1m, 2m, 3m, 5m and 10m lengths.



1-800-333-0852
www.erico.com

ERICO®



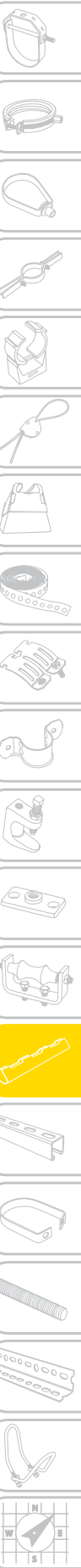

Page 156

125



Page 157

121



Page 158

126

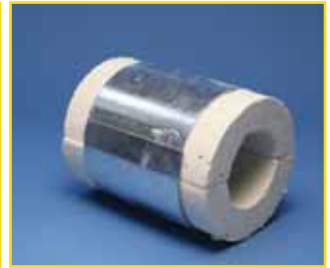

Page 159

127



Page 160

630



Page 161

631



Page 162

632



Page 163

633



Page 164

634



Page 165

635

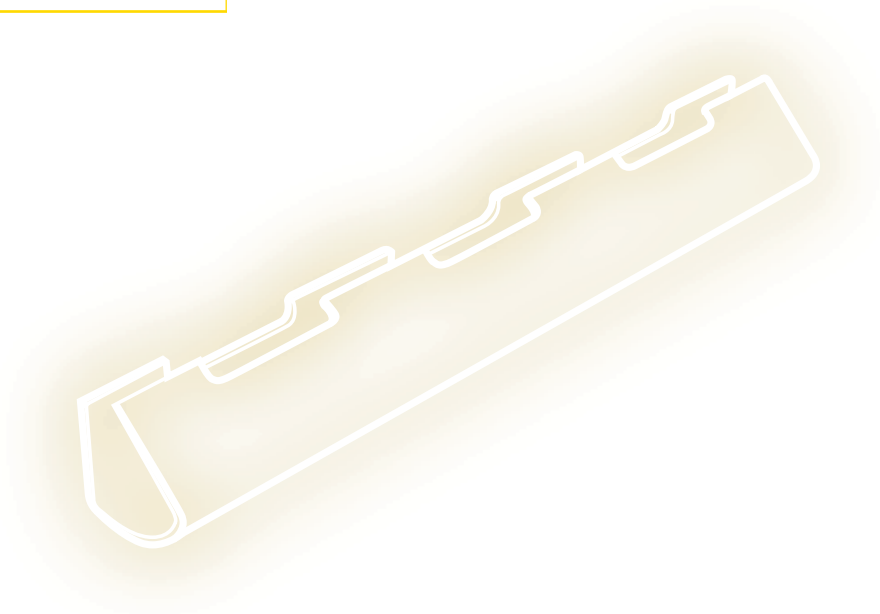

INSULATION SHIELD 125

Low Compression Insulation Shield

- Size Range: 1-1/2" thru 28"
- Surface Finish: Electro-zinc plated
- Resists crushing insulation at the point of support when the insulation has more than 5% deformation at 30 psi
- Conforms with Federal Specification WW-H-171 (Type 41), Manufacturers Standardization Society ANSI/MSS-SP-58 (Type 40); install in accordance with ANSI/MSS-SP-69



NOTE: Shield size directly corresponds to hanger size into which it will nest, see Models 126 and 127 for pre-insulated pipe support systems

Part Number	Shield Size	A	B	Gauge
1250150EG	1-1/2	2-1/8"	12"	18
1250200EG	2	2-1/2"	12"	18
1250250EG	2-1/2	3"	12"	18
1250300EG	3	3-5/8"	12"	18
1250350EG	3-1/2	4-1/8"	12"	18
1250400EG	4	4-5/8"	12"	16
1250450EG	4-1/2	5"	12"	18
1250500EG	5	5-9/16"	12"	18
1250600EG	6	6-5/8"	12"	16
1250700EG	7	7-5/8"	12"	16
1250701EG	7A	7-5/8"	18"	16
1250800EG	8	8-3/8"	12"	16
1250801EG	8A	8-5/8"	18"	16
1250900EG	9	9-5/8"	18"	16
1251000EG	10	10-3/4"	18"	16
1251100EG	11	11-3/4"	24"	14
1251200EG	12	12-3/4"	24"	14
1251400EG	14	14"	24"	14
1251500EG	15	15"	24"	14
1251600EG	16	16"	24"	14
1251800EG	18	18"	24"	12
1251900EG	19	19"	24"	12
1252000EG	20	20"	24"	12
1252200EG	22	22"	24"	12
1252400EG	24	24"	24"	12
1252800EG	28	28"	24"	12

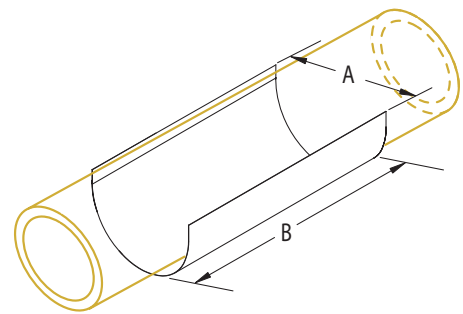

INSULATION SHIELD 121

High Density Insulation Shield

- Size Range: 1-1/2" thru 10"
- Surface Finish: Black
- Use with high density pipe covering or where hard block at the point of support is needed

NOTE: Shield size directly corresponds to hanger size into which it will nest. Available in Electro-zinc plated finish by special order



Part Number	Shield Size	A	B	Gauge
1210150PL	1-1/2	1-7/8"	3"	19
1210200PL	2	2-3/8"	3"	19
1210250PL	2-1/2	3-1/8"	4"	19
1210300PL	3	3-5/8"	4"	19
1210350PL	3-1/2	4"	4"	19
1210400PL	4	4-1/2"	6"	19
1210500PL	5	5-9/16"	6"	19
1210600PL	6	6-5/8"	6"	19
1210800PL	8	8-5/8"	6"	19
1211000PL	10	10-3/4"	6"	19

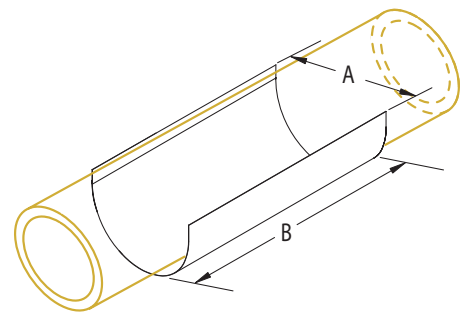

INSULATION SHIELD 126

360° Shield and Insulation – Hot Piping

- Size Range: 1/2" thru 18" pipe, 1" thru 4" insulation thickness
- Prevents crushed insulation at the point of support
- For use with hot services
- 140 psi minimum compressive strength, -20°F to 1200°F working temperature, and detailed insulation specifications available on request
- When ordering specify pipe or tubing size, insulation thickness, model number, and name

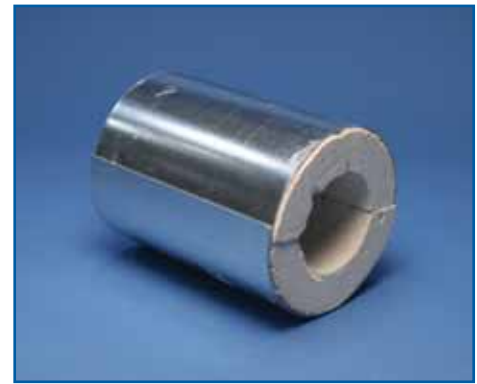

Construction:

- 360°, 2 piece pre-galvanized metal jacket encasing asbestos free, hydrous calcium silicate, treated for water resistance. Insulation is affixed inside top and bottom halves of the metal jacket where bottom jacket overlaps top and is assembled by sliding together

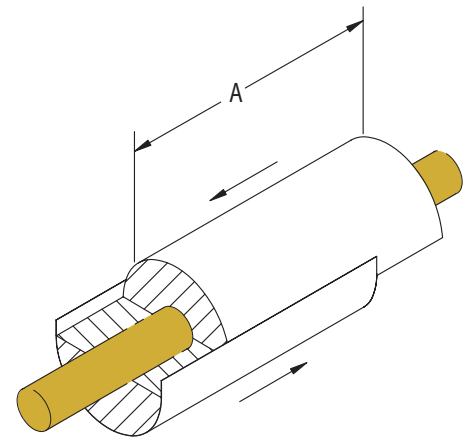

Pipe or Tubing Size	"A" Insulation Length					
	Based on Insulation Thickness of*					
	1"	1-1/2"	2"	2-1/2"	3"	4"
1/2" thru 1-1/2"	6"	6"	6"	6"	6"	6"
2" thru 5"	6"	6"	6"	6"	9"	9"
6" thru 10"	9"	9"	9"	9"	9"	9"
12" thru 14"	9"	9"	9"	9"	9"	9"
16" thru 24"	12"	12"	12"	12"	12"	12"

*Cold water inserts have a minimum insulation length of 6"

Pipe or Tubing Size	Sheet Metal Gauge					
	Based on Insulation Thickness of**					
	1"	1-1/2"	2"	2-1/2"	3"	4"
1/2" thru 1-1/2"	22	22	22	20	20	20
2" thru 5"	20	20	20	20	20	20
6" thru 10"	16	16	16	16	16	16
12" thru 14"	16	16	16	16	16	16
16" thru 24"	14	14	14	14	14	14

**A double thickness of sheet metal is recommended on the lower half when used with rollers or when hanger span exceeds 10'



INSULATION SHIELD 127

360° Shield and Insulation – Cold Piping

- Size Range: 1/2" thru 18" pipe, 1" thru 4" insulation thickness
- Prevents crushed insulation at the point of support
- For use with cold services
- 140 psi minimum compressive strength, -20°F to 1200°F working temperature, and detailed insulation specifications available on request
- When ordering specify pipe or tubing size, insulation thickness, model number, and name

Construction:

- 360°, 2 piece pre-galvanized metal jacket encasing asbestos free, hydrous calcium silicate, treated for water resistance. Insulation has vapor barrier and extends 1" beyond metal jacket so joint may be taped to make complete vapor barrier between insert and line insulation

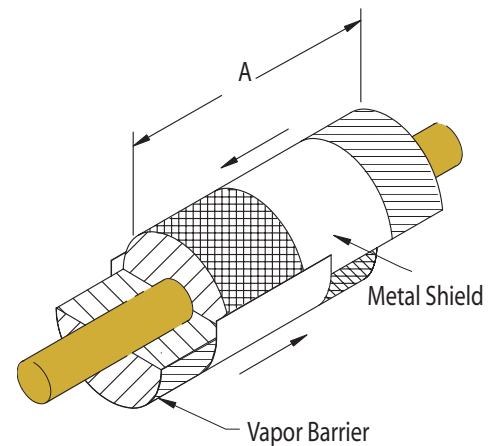

Pipe or Tubing Size	"A" Insulation Length					
	Based on Insulation Thickness of*					
	1"	1-1/2"	2"	2-1/2"	3"	4"
1/2" thru 1-1/2"	6"	6"	6"	6"	6"	6"
2" thru 5"	6"	6"	6"	6"	9"	9"
6" thru 14"	9"	9"	9"	6"	9"	9"
16" thru 24"	12"	12"	12"	12"	12"	12"

*Cold water inserts have a minimum insulation length of 6"

Pipe or Tubing Size	Sheet Metal Gauge					
	Based on Insulation Thickness of**					
	1"	1-1/2"	2"	2-1/2"	3"	4"
1/2" thru 1-1/2"	22	22	22	20	20	20
2" thru 5"	20	20	20	20	20	20
6" thru 14"	16	16	16	16	16	16
16" thru 24"	16	16	16	16	16	16

**A double thickness of sheet metal is recommended on the lower half when used with rollers or when hanger span exceeds 10'

PIPE SADDLE 630

Protection Saddle for 1" Pipe Insulation

- Size Range: 3/4" thru 8"
- Surface Finish: Black
- Designed for high temperature service or where heat losses are to be kept at a minimum and to protect insulation against damage at the point of support
- Conforms with Federal Specification WW-H-171 (Type 40A or 40B), Manufacturers Standardization Society ANSI/MSS-SP-58 (Type 39A or 39B); install in accordance with ANSI/MSS-SP-69



NOTE: Larger sizes available upon request

Part Number	Pipe Size	Actual Thickness of Cover	Size of Pipe Roll for Model #			Center Line of Pipe to Outside of Saddle	Center Line of Pipe to Center Line of Roll for Model #			Max. Rec. Load (lbs)*
			600,605 615,620	610 612	617 619		600,605 615,620	610 612	617 619	
6300150PL	3/4"	7/8"	2-1/2	2-1/2	2 to 3-1/2	1-3/4"	2-3/16"	2-1/4"	2-3/8"	1200
	1"	1-1/16"	2-1/2	3	2 to 3-1/2	1-15/16"	2-7/16"	2-3/8"	3"	1200
	1-1/4"	7/8"	2-1/2	3	2 to 3-1/2	2-1/8"	2-11/16"	2-5/8"	2-3/4"	1200
	1-1/2"	1"	3	3-1/2	2 to 3-1/2	2-1/4"	2-3/4"	2-3/4"	2-1/4"	1200
6300350PL	2"	1-1/16"	3-1/2	4	2 to 3-1/2	2-7/16"	3-1/16"	3"	3"	1200
	2-1/2"	1-1/16"	3-1/2	5	2 to 3-1/2	2-3/4"	3-5/16"	3-5/16"	3-3/8"	1200
	3"	1"	4	5	2 to 3-1/2	3-1/16"	3-5/8"	3-5/8"	3-11/16"	1200
	3-1/2"	1-1/4"	5	6	4 to 6	3-3/8"	4-1/16"	4-1/16"	4"	1200
6300500PL	4"	1-1/16"	5	6	4 to 6	3-7/16"	4-1/8"	4-1/8"	4-1/16"	1800
	5"	1"	6	8	4 to 6	4-1/16"	4-3/4"	4-3/4"	4-11/16"	1800
6300600PL	6"	1"	8	8	4 to 6	4-9/16"	5-3/8"	5-3/8"	5-1/4"	1800
6300800PL	8"	1-1/2"	10	12	8 to 10	6"	7-1/16"	7-1/16"	7-1/16"	1800

*Maximum recommended loads are applicable only when the saddle is used on a flat bearing surface and tack welded to the pipe. When a saddle is used with a pipe roll, the maximum load given for the pipe roll applies to the saddle

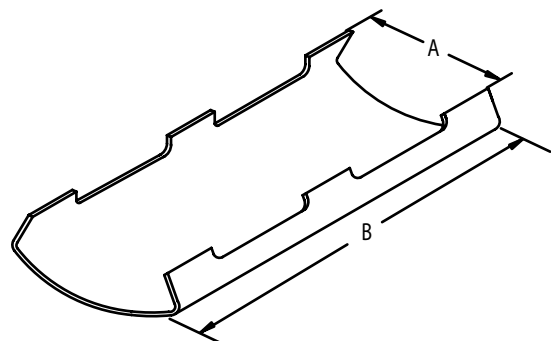

PIPE SADDLE 631

Protection Saddle for 1-1/2" Pipe Insulation

- Size Range: 3/4" thru 24"
- Surface Finish: Black
- Designed for high temperature service or where heat losses are to be kept at a minimum and to protect insulation against damage at the point of support
- Conforms with Federal Specification WW-H-171 (Type 40A or 40B), Manufacturers Standardization Society ANSI/MSS-SP-58 (Type 39A or 39B); install in accordance with ANSI/MSS-SP-69



NOTE: Larger sizes available upon request. Saddles have a welded-in center plate for pipe sizes 12" and larger, see Type A

Part Number	Pipe Size	Actual Thickness of Cover	Size of Pipe Roll for Model #			Center Line of Pipe to Outside of Saddle	Center Line of Pipe to Center Line of Roll for Model #			Max. Rec. Load (lbs)*
			600,605 615,620	610 612	617 619		600,605 615,620	610 612	617 619	
6310150PL	3/4"	1-7/16"	3	3-1/2	2 to 3-1/2	2-1/8"	2-11/16"	2-11/16"	3-13/16"	1200
	1"	1-9/16"	3	4	2 to 3-1/2	2-7/16"	3"	3"	3-1/8"	1200
	1-1/4"	1-5/8"	3-1/2	5	2 to 3-1/2	2-9/16"	3-1/16"	3-1/16"	3-3/16"	1200
	1-1/2"	1-1/2"	3-1/2	5	2 to 3-1/2	2-11/16"	3-5/16"	3-5/16"	3-5/16"	1200
6310350PL	2"	1-9/16"	4	5	2 to 3-1/2	3"	3-5/8"	3-5/8"	3-5/8"	1200
	2-1/2"	1-7/16"	5	6	2 to 3-1/2	3-1/4"	3-15/16"	3-15/16"	3-7/8"	1200
	3"	1-9/16"	5	6	2 to 3-1/2	3-5/8"	4-5/16"	4-5/16"	4-1/4"	1800
6310500PL	3-1/2"	1-13/16"	6	8	4 to 6	3-7/8"	4-3/4"	4-3/4"	4-11/16"	1800
	4"	1-9/16"	6	8	4 to 6	3-7/8"	4-11/16"	4-11/16"	4-9/16"	1800
6310800PL	5"	1-1/2"	8	8	4 to 6	4-1/2"	5-5/16"	5-5/16"	5-3/16"	1800
	6"	1-1/2"	8	10	8 to 10	5-3/16"	6"	5-13/16"	6-1/8"	1800
6311000PL	8"	1-1/2"	10	12	8 to 10	6-5/16"	7-3/8"	7-3/8"	7-3/8"	1800
	10"	1-9/16"	12	14	8 to 10	7-1/4"	8-5/16"	8-1/2"	8-5/16"	1800
6311200PL	12"	1-1/2"	14	16	12 to 14	8-1/16"	8-1/16"	9-1/2"	9-1/4"	5000
6311400PL	14"	1-1/2"	16	18	12 to 14	8-7/8"	8-7/8"	10-1/2"	10-3/16"	5000
6311600PL	16"	1-1/2"	18	20	16 to 20	9-7/8"	11-5/16"	11-5/16"	11-3/16"	5000
6311800PL	18"	1-1/2"	20	N/A	16 to 20	10-7/8"	12-3/8"	N/A	12-1/4"	5000
6312000PL	20"	1-1/2"	24	N/A	24 to 26	11-3/4"	13-11/16"	N/A	13-3/16"	7200
6312400PL	24"	1-1/2"	30	N/A	22 to 30	13-5/8"	16-7/16"	N/A	15-3/8"	7200

*Maximum recommended loads are applicable only when the saddle is used on a flat bearing surface and tack welded to the pipe. When a saddle is used with a pipe roll, the maximum load given for the pipe roll applies to the saddle

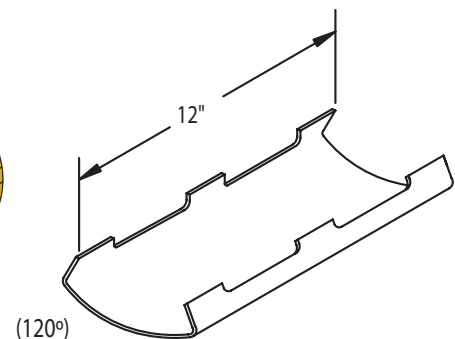
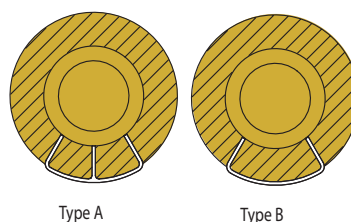

PIPE SADDLE 632

Protection Saddle for 2" Pipe Insulation

- Size Range: 3/4" thru 24"
- Surface Finish: Black
- Designed for high temperature service or where heat losses are to be kept at a minimum and to protect insulation against damage at the point of support
- Conforms with Federal Specification WW-H-171 (Type 40A or 40B), Manufacturers Standardization Society ANSI/MSS-SP-58 (Type 39A or 39B); install in accordance with ANSI/MSS-SP-69



NOTE: Larger sizes available upon request. Saddles have a welded-in center plate for pipe sizes 12" and larger, see Type A

Part Number	Pipe Size	Actual Thickness of Cover	Size of Pipe Roll for Model #			Center Line of Pipe to Outside of Saddle	Center Line of Pipe to Center Line of Roll for Model #			Max. Rec. Load (lbs)*
			600,605 615,620 621	610 612	617 619		600,605 615,620 621	610 612	617 619	
6320150PL	3/4"	1-7/8"	4	5	2 to 3-1/2	2-3/4"	3-3/8"	3-3/8"	3-7/16"	1200
	1"	2-1/8"	4	5	2 to 3-1/2	2-15/16"	3-9/16"	3-9/16"	3-9/16"	1200
	1-1/4"	1-15/16"	4	5	2 to 3-1/2	3-1/8"	3-3/4"	3-3/4"	3-13/16"	1200
	1-1/2"	2-5/16"	5	5	4 to 6	3-1/4"	4-1/8"	4-1/8"	4-1/8"	1800
6320350PL	2"	2-1/8"	5	6	4 to 6	3-1/2"	4-3/16"	4-3/16"	4-3/16"	1800
	2-1/2"	2-5/16"	6	8	4 to 6	3-3/4"	4-3/8"	4-1/2"	4-3/8"	1800
	3"	2-1/16"	6	8	4 to 6	4-1/8"	4-13/16"	4-13/16"	4-11/16"	1800
	3-1/2"	2-1/4"	6	8	4 to 6	4-3/8"	5-3/16"	5-3/16"	5-1/16"	1800
6320500PL	4"	2-1/16"	8	8	4 to 6	4-11/16"	5-1/2"	5-1/2"	5-3/8"	1800
	5"	2"	8	10	8 to 10	4-15/16"	5-3/4"	5-13/16"	5-7/8"	1800
6320800PL	6"	2"	10	10	8 to 10	5-11/16"	6-5/8"	6-5/8"	6-11/16"	1800
	8"	2"	10	12	8 to 10	6-13/16"	7-7/8"	7-7/8"	7-7/8"	1800
6321000PL	10"	2-1/16"	14	16	12 to 14	7-5/8"	9-1/16"	9"	8-13/16"	1800
6321200PL	12"	2-1/16"	16	18	16 to 20	8-13/16"	8-3/16"	10-1/4"	10-3/16"	5000
6321400PL	14"	2"	16	18	16 to 20	9-1/4"	9-1/4"	10-3/4"	10-5/8"	5000
6321600PL	16"	2"	18	20	16 to 20	10-1/4"	11-13/16"	11-13/16"	11-5/8"	5000
6321800PL	18"	2"	20	N/A	22 to 24	11-1/2"	13-1/16"	N/A	12-7/8"	7200
6322000PL	20"	2"	24	N/A	22 to 24	12-5/16"	14-3/16"	N/A	13-11/16"	7200
6322400PL	24"	2"	30	N/A	26 to 30	14-3/16"	17-1/16"	N/A	15-15/16"	7200

*Maximum recommended loads are applicable only when the saddle is used on a flat bearing surface and tack welded to the pipe. When a saddle is used with a pipe roll, the maximum load given for the pipe roll applies to the saddle

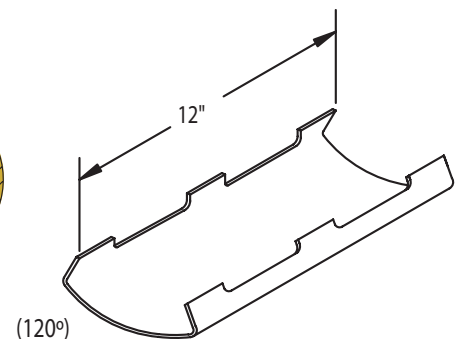
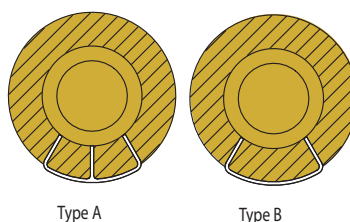

PIPE SADDLE 633

Protection Saddle for 2-1/2" Pipe Insulation

- Size Range: 1-1/4" thru 24"
- Surface Finish: Black
- Designed for high temperature service or where heat losses are to be kept at a minimum and to protect insulation against damage at the point of support
- Conforms with Federal Specification WW-H-171 (Type 40A or 40B), Manufacturers Standardization Society ANSI/MSS-SP-58 (Type 39A or 39B); install in accordance with ANSI/MSS-SP-69



NOTE: Larger sizes available upon request. Saddles have a welded-in center plate for pipe sizes 12" and larger, see Type A

Part Number	Pipe Size	Actual Thickness of Cover	Size of Pipe Roll for Model #			Center Line of Pipe to Outside of Saddle	Center Line of Pipe to Center Line of Roll for Model #			Max. Rec. Load (lbs)*
			600,605	610	617		600,605	610	617	
			615,620	612	619		615,620	612	619	
6330150PL	1-1/4"	2-7/16"	5	6	4 to 6	3-3/4"	4-3/8"	4-3/8"	4-3/8"	1200
	1-1/2"	2-13/16"	6	5	4 to 6	3-13/16"	4-7/16"	4-7/16"	4-9/16"	1800
6330200PL	2"	2-5/8"	6	8	4 to 6	3-15/16"	4-5/8"	4-11/16"	4-11/16"	1800
6330250PL	2-1/2"	2-7/8"	8	8	4 to 6	4-7/16"	5-5/16"	5-5/16"	5-3/16"	1800
6330300PL	3"	2-9/16"	8	8	4 to 6	4-11/16"	5-7/16"	5-7/16"	5-5/16"	1800
6330350PL	3-1/2"	2-3/4"	8	10	8 to 10	4-13/16"	5-3/4"	5-3/4"	5-13/16"	1800
6330500PL	4"	2-9/16"	8	10	8 to 10	5-1/8"	6-1/16"	6-1/16"	6-3/4"	1800
	5"	2-9/16"	10	10	8 to 10	5-9/16"	6-1/2"	6-1/2"	6-9/16"	1800
6330800PL	6"	2-1/2"	10	12	8 to 10	6-3/16"	7-1/8"	7-13/16"	7-1/4"	1800
	8"	2-11/16"	12	14	8 to 10	7-5/16"	8-3/8"	8-9/16"	8-3/8"	1800
6331000PL	10"	2-9/16"	14	16	12 to 14	8-3/16"	9-5/8"	9-5/8"	9-3/8"	1800
6331600PL	16"	2-1/2"	20	N/A	16 to 20	10-7/8"	12-3/8"	N/A	12-7/8"	7200
6331800PL	18"	2-1/2"	24	N/A	22 to 24	12"	13-15/16"	N/A	13-7/16"	7200
6332000PL	20"	2-1/2"	24	N/A	22 to 24	12-7/8"	14-13/16"	N/A	14-5/16"	7200
6332400PL	20"	2-1/2"	30	N/A	26 to 30	14-3/4"	17-5/8"	N/A	16-9/16"	7200

*Maximum recommended loads are applicable only when the saddle is used on a flat bearing surface and tack welded to the pipe. When a saddle is used with a pipe roll, the maximum load given for the pipe roll applies to the saddle

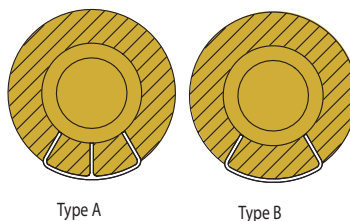

Type A

Type B

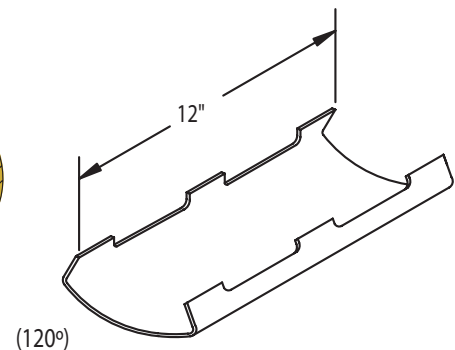

PIPE SADDLE 634

Protection Saddle for 3" Pipe Insulation

- Size Range: 2" thru 24"
- Surface Finish: Black
- Designed for high temperature service or where heat losses are to be kept at a minimum and to protect insulation against damage at the point of support
- Conforms with Federal Specification WW-H-171 (Type 40A or 40B), Manufacturers Standardization Society ANSI/MSS-SP-58 (Type 39A or 39B); install in accordance with ANSI/MSS-SP-69



NOTE: Larger sizes available upon request. Saddles have a welded-in center plate for pipe sizes 12" and larger, see Type A

Part Number	Pipe Size	Actual Thickness of Cover	Size of Pipe Roll for Model #			Center Line of Pipe to Outside of Saddle	Center Line of Pipe to Center Line of Roll for Model #			Max. Rec. Load (lbs)*
			600,605 615,620 621	610 612	617 619		600,605 615,620 621	610 612	617 619	
6340200PL	2"	3-1/8"	8	8	4 to 6	4-11/16"	5-1/2"	5-1/2"	5-1/2"	1800
6340250PL	2-1/2"	3-3/8"	8	10	4 to 6	4-15/16"	5-11/16"	5-13/16"	5-9/16"	1800
6340300PL	3"	3-1/16"	8	10	8 to 10	5"	5-15/16"	5-15/16"	6"	1800
6340350PL	3-1/2"	3-5/16"	10	10	8 to 10	5-1/2"	6-7/16"	6-7/16"	6-1/2"	1800
6340500PL	4"	3-1/16"	10	10	8 to 10	5-9/16"	6-1/2"	6-1/2"	7-1/2"	1800
	5"	3-1/16"	10	12	8 to 10	6-1/8"	7-1/16"	7-3/16"	7-3/16"	1800
6340800PL	6"	3"	12	12	8 to 10	6-9/16"	7-5/8"	7-5/8"	7-5/8"	1800
	8"	3-1/8"	14	16	12 to 14	7-5/8"	8-15/16"	8-15/16"	8-11/16"	1800
6341000PL	10"	3-1/16"	16	18	16 to 20	8-7/8"	10-5/16"	10-7/8"	10-3/16"	1800
6341200PL	12"	3-1/16"	18	20	16 to 20	9-11/16"	9-11/16"	11-3/16"	11-1/16"	5000
6341400PL	14"	3"	18	20	16 to 20	10-1/4"	10-1/4"	11-11/16"	11-1/8"	5000
6341600PL	16"	3"	24	N/A	22 to 24	11-3/16"	13"	N/A	12-9/16"	7200
6341800PL	18"	3"	24	N/A	22 to 24	12-5/16"	14-1/4"	N/A	13-11/16"	7200
6342000PL	20"	3"	24	N/A	22 to 24	13-1/2"	15-7/16"	N/A	14-15/16"	7200
6342400PL	24"	3"	30	N/A	26 to 30	15-3/8"	18-3/16"	N/A	17-1/8"	7200

*Maximum recommended loads are applicable only when the saddle is used on a flat bearing surface and tack welded to the pipe. When a saddle is used with a pipe roll, the maximum load given for the pipe roll applies to the saddle

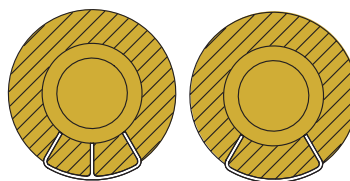

Type A

Type B

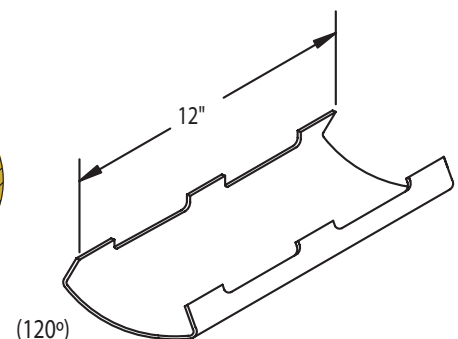

PIPE SADDLE 635

Protection Saddle for 4" Pipe Insulation

- Size Range: 4" thru 24"
- Surface Finish: Black
- Designed for high temperature service or where heat losses are to be kept at a minimum and to protect insulation against damage at the point of support
- Conforms with Federal Specification WW-H-171 (Type 40A or 40B), Manufacturers Standardization Society ANSI/MSS-SP-58 (Type 39A or 39B); install in accordance with ANSI/MSS-SP-69



NOTE: Larger sizes available upon request. Saddles have a welded-in center plate for pipe sizes 12" and larger, see Type A

Part Number	Pipe Size	Actual Thickness of Cover	Size of Pipe Roll for Model #			Center Line of Pipe to Outside of Saddle	Center Line of Pipe to Center Line of Roll for Model #			Max. Rec. Load (lbs)*
			600,605	610	617		600,605	610	617	
			615,620	612	619		615,620	612	619	
6350400PL	4"	4-1/16"	10	12	8 to 10	6-9/16"	7-11/16"	7-11/16"	7-5/8"	1800
6350500PL	5"	4-3/16"	12	14	8 to 10	7-3/16"	8-1/4"	8-7/16"	8-1/4"	1800
6350800PL	6"	4-1/8"	14	16	12 to 14	7-5/8"	9-1/16"	9-1/16"	8-13/16"	1800
	8"	4-1/8"	16	18	12 to 14	8-11/16"	10-1/8"	10-1/8"	9-7/8"	1800
6351000PL	10"	4-1/16"	18	20	16 to 20	9-11/16"	11-3/16"	11-3/16"	11-1/16"	1800
6351200PL	12"	4-1/8"	20	N/A	16 to 20	10-13/16"	13"	N/A	12-13/16"	5000
6351600PL	16"	4"	24	N/A	22 to 24	12-5/16"	14-1/4"	N/A	13-3/4"	7200
6351800PL	18"	4"	24	N/A	22 to 24	13-1/2"	15-7/16"	N/A	14-15/16"	7200
6352000PL	20"	4"	30	N/A	26 to 30	14-3/16"	17-1/16"	N/A	15-15/16"	7200
6352400PL	24"	4"	30	N/A	26 to 30	16-9/16"	19-3/8"	N/A	18-5/16"	7200

*Maximum recommended loads are applicable only when the saddle is used on a flat bearing surface and tack welded to the pipe. When a saddle is used with a pipe roll, the maximum load given for the pipe roll applies to the saddle

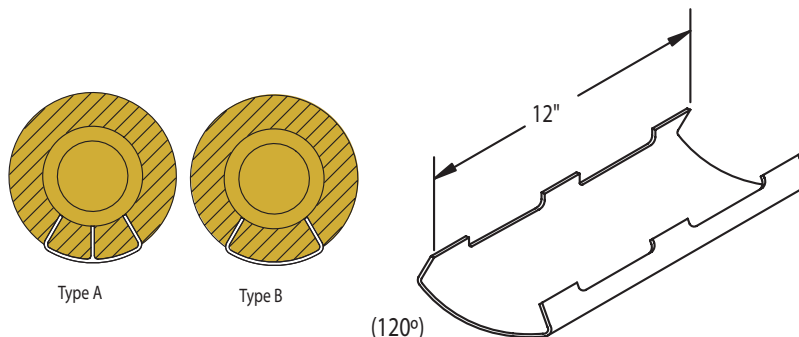

NEW Products



CADDY® SLICK STRUT NUT

- Reduce installation time and inventory by over 75%
- Integral plastic strip provides tension to grip the strut, even vertically
- Allows for easy repositioning or removal

See page 178



CADDY® CHANNEL CLAMP STS (STRUT-TO-STRUT)

- Provides fast assembly of back-to-back half-slot strut as an alternative to welded strut
- Unique one-piece assembly eliminates the need for washers, bolts and nuts
- For new or retrofit applications

See page 179



STRUT BEAM CLAMP STCB

- Structural attachment to beams to support threaded rod and/or strut
- Maximum flange thickness: 3/4" when used with 1-5/8" strut and 1-5/8" when used with 13/16" strut

See page 185



STRUT PIPE CLAMPS - Refer to Chapter 9, page 74



STRUT ROLLERS - Refer to Chapter 13, page 142



STRUT, FITTINGS & ACCESSORIES CHAPTER 15



Page 173

A12



Page 174

A14



Page 174

B12



Page 175

C12



Page 176

C14



Page 176

D12



Page 177

E12



Page 177

CONC



Page 178

CADDY® SLICK



Page 179

STS



Page 180

NUT



Page 180

NUTC



Page 181

SPRA



Page 181

SPRC



Page 182

SPRD



Page 182

SPRM

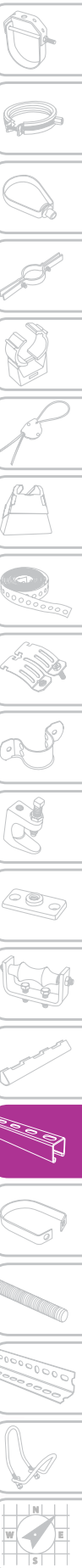

STRUT, FITTINGS & ACCESSORIES CHAPTER 15

NEW



Page 183

TSNT



Page 184

SQNT



Page 184

VS



Page 185

STCB



Page 186

BC16



Page 186

BC17



Page 187

BR22



Page 187

Strut Cover

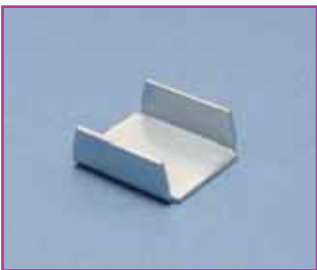

Page 188

ENDC



Page 188

F09



Page 189

F10-F12



Page 189

F13-F18



Page 190

F20



Page 190

F22

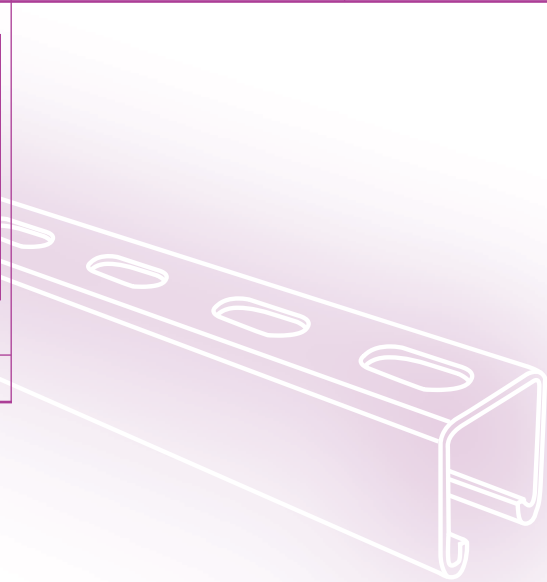

STRUT, FITTINGS & ACCESSORIES CHAPTER 15



Page 191

F23



Page 191

F25



Page 192

F36



Page 192

F37



Page 193

L10



Page 193

L11

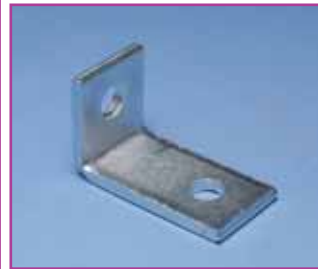

Page 194

L12



Page 194

L15



Page 195

L16-L17



Page 195

L18



Page 196

L19-L20



Page 196

L22



Page 197

L23



Page 197

L24

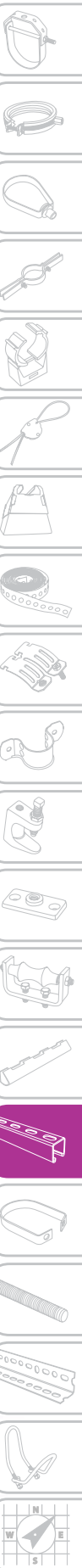
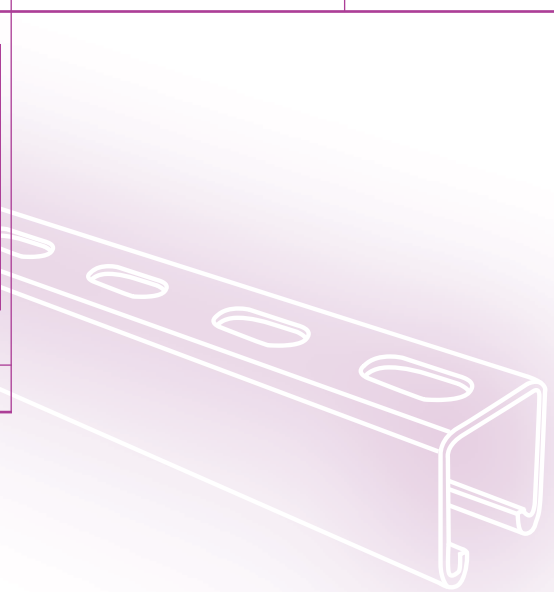

STRUT, FITTINGS & ACCESSORIES CHAPTER 15

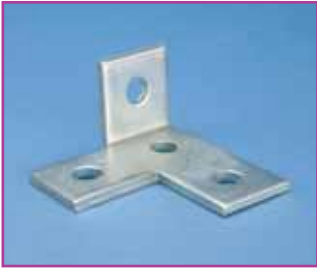

Page 198

L25



Page 198

L26



Page 199

L27



Page 199

L44



Page 200

L46



Page 200

L47



Page 201

P09



Page 201

P10



Page 202

P11



Page 202

P13



Page 203

ROL10



Page 203

ROL11



Page 204

U10A



Page 204

U24

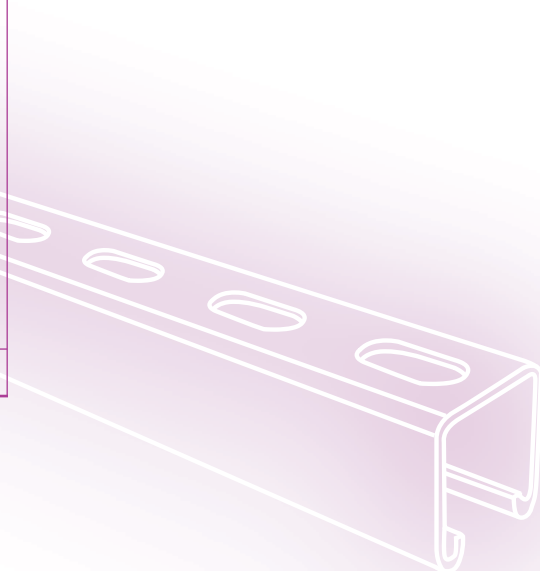

STRUT, FITTINGS & ACCESSORIES CHAPTER 15



Page 205

W10



Page 205

W12



Page 206

W13



Page 206

W17



Page 207

W18



Page 207

W19



Page 208

W20



Page 208

W23



CADDY® ERISTRUT CHANNEL

Model Number	Width	Height	Gauge
A12	1-5/8"	1-5/8"	12
A14	1-5/8"	1-5/8"	14
B12	1-5/8"	1-3/8"	12
C12	1-5/8"	13/16"	12
C14	1-5/8"	13/16"	14
D12	1-5/8"	2-7/16"	12
E12	1-5/8"	3-1/4"	12

Complete CADDY® ERISTRUT channel specifications, including **Finish, Fittings, Hardware, Load Applications and Beam and Column Loads Data** information is available in chapter 20 at the end of this catalog.

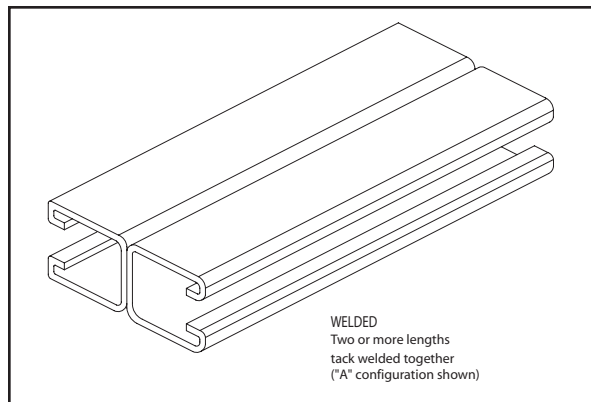
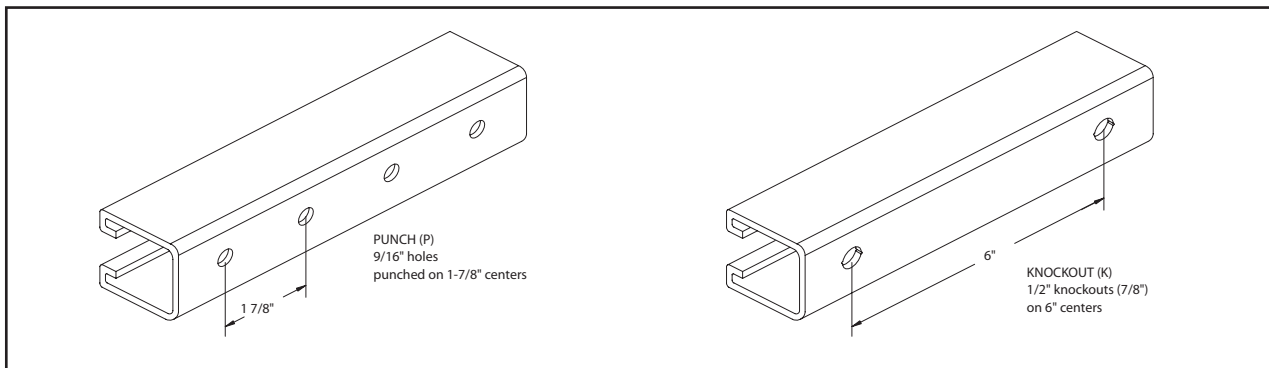
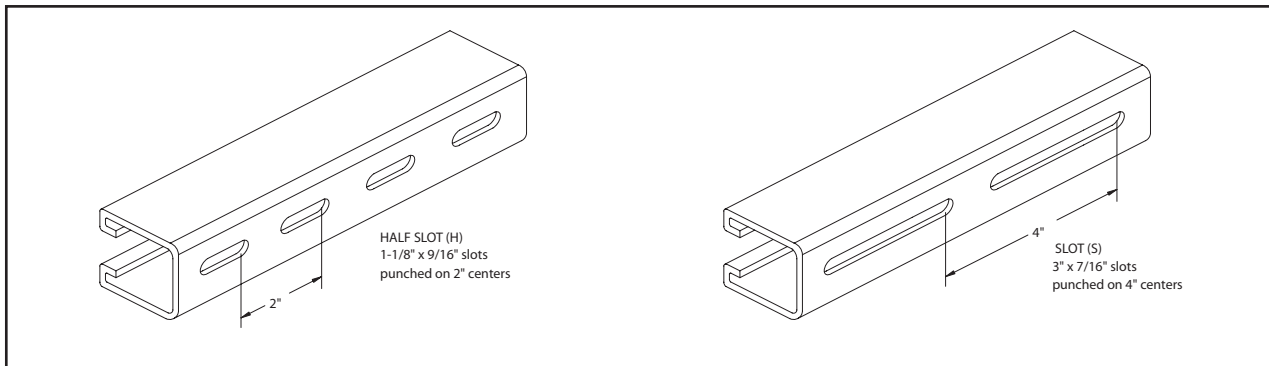

CADDY® ERISTRUT CHANNEL A12

12 GA Strut

- 1-5/8" x 1-5/8"
- For heavy applications
- For individual fastening or for efficiently constructing pipe or tube routes
- Standard lengths: 10', 20'
- Surface Finish(es): Pre-galvanized, painted green, gold chromate, plain



Part Number	Welded Configuration	Hole/Slot Configuration	Length (ft)
Pre-galvanized Finish			
A121000PG	-	Solid	10
A122000PG	-	Solid	20
A12A2000PG	A	Solid	20
A12AH100PG	A	Half Slot	10
A12AH200PG	A	Half Slot	20
A12H1000PG	-	Half Slot	10
A12H2000PG	-	Half Slot	20
Painted Green Finish			
A122000GN	-	Solid	20
A12A2000GN	A	Solid	20
A12AH200GN	A	Half Slot	20
A12H1000GN	-	Half Slot	10
A12H2000GN	-	Half Slot	20
Plain Finish			
A122000PL	-	Solid	20
Gold Chromate Finish			
A12H1000CG	-	Half Slot	10
A12H2000CG	-	Half Slot	20
304 Stainless Steel			
A12H1000S4	-	Half Slot	10



CADDY® ERISTRUT CHANNEL A14

14 GA Strut

- 1-5/8" x 1-5/8"
- For light – medium applications
- For individual fastening or for efficiently constructing pipe or tube routes
- Standard lengths: 10', 20'
- Surface Finish(es): Pre-galvanized, painted green



Part Number	Hole/Slot Configuration	Length (ft)
Pre-galvanized Finish		
A14H1000PG	Half Slot	10
A14H2000PG	Half Slot	20
Painted Green Finish		
A14H1000GN	Half Slot	10
A14H2000GN	Half Slot	20

CADDY® ERISTRUT CHANNEL B12

12 GA Strut

- 1-5/8" x 1-3/8"
- For heavy applications
- For individual fastening or for efficiently constructing pipe or tube routes
- Standard lengths: 10', 20'
- Surface Finish(es): Pre-galvanized, painted green



Part Number	Hole/Slot Configuration	Length (ft)
Pre-galvanized Finish		
B122000PG	Solid	20
B12H1000PG	Half Slot	10
B12H2000PG	Half Slot	20
Painted Green Finish		
B122000GN	Solid	20
B12H2000GN	Half Slot	20



CADDY® ERISTRUT CHANNEL C12

12 GA Strut

- 1-5/8" x 13/16"
- For medium – heavy applications
- For individual fastening or for efficiently constructing pipe or tube routes
- Standard lengths: 10', 20'
- Surface Finish(es): Pre-galvanized, painted green, gold chromate



Part Number	Hole/Slot Configuration	Length (ft)
Pre-galvanized Finish		
C121000PG	Solid	10
C12H1000PG	Half Slot	10
C12H2000PG	Half Slot	20
Painted Green Finish		
C122000GN	Solid	20
C12H1000GN	Half Slot	10
C12H2000GN	Half Slot	20
Gold Chromate Finish		
C12H1000CG	Half Slot	10
Aluminum		
C121000AL	Solid	10
C122000AL	Solid	20



CADDY® ERISTRUT CHANNEL C14

14 GA Strut

- 1-5/8" x 13/16"
- For light – medium applications
- For individual fastening or for efficiently constructing pipe or tube routes
- Standard lengths: 10', 20'
- Surface Finish(es): Pre-galvanized, painted green, gold chromate



Part Number	Hole/Slot Configuration	Length (ft)
Pre-galvanized Finish		
C141000PG	Solid	10
C14H1000PG	Half Slot	10
C14H2000PG	Half Slot	20
Painted Green Finish		
C14H1000GN	Half Slot	10
C14H2000GN	Half Slot	20
C14S2000GN	Full Slot	20
Gold Chromate Finish		
C14H1000CG	Half Slot	10
C14H2000CG	Half Slot	20
304 Stainless Steel		
C141000S4	Solid	10
C142000S4	Solid	20
C14H1000S4	Half Slot	10

CADDY® ERISTRUT CHANNEL D12

12 GA Strut

- 1-5/8" x 2-7/16"
- For heavy applications
- For individual fastening or for efficiently constructing pipe or tube routes
- Standard lengths: 10', 20'
- Surface Finish(es): Pre-galvanized, painted green



Part Number	Hole/Slot Configuration	Length (ft)
Pre-galvanized Finish		
D122000PG	Solid	20
D12H1000PG	Half Slot	10
D12H2000PG	Half Slot	20
Painted Green Finish		
D12H1000GN	Half Slot	10
D12H2000GN	Half Slot	20
D12S2000GN	Full Slot	20



CADDY® ERISTRUT CHANNEL E12

12 GA Strut

- 1-5/8" x 3-1/4"
- For heavy applications
- For individual fastening or for efficiently constructing pipe or tube routes
- Standard lengths: 10', 20'
- Surface Finish(es): Pre-galvanized, painted green



Part Number	Hole/Slot Configuration	Length (ft)
Pre-galvanized Finish		
E12H1000PG	Half Slot	10
E12H2000PG	Half Slot	20
Painted Green Finish		
E122000GN	Solid	20
E12H1000GN	Half Slot	10
E12H2000GN	Half Slot	20

CADDY® ERISTRUT CHANNEL CONC

12 GA Continuous Concrete Insert Channel

- For individual fastening or for efficiently constructing pipe or tube routes
- Standard lengths: 10', 20'
- Standard Surface Finish: Pre-galvanized



Part Number	Hole/Slot Configuration	Length (ft)
Pre-galvanized Finish		
CONA122000PG	Half Slot	20
CONB122000PG	Half Slot	20
CONC122000PG	Half Slot	20

CADDY® SLICK STRUT NUT

One-piece Strut Nut

- Size Range: 1/4", 3/8" and 1/2" thread sizes
- Surface Finish: Dacromet 320
- Provides fast, universal attachment of threaded rod and hardware to standard strut profiles
- Unique 1-piece design
- Eliminates the need for a washer
- Fits all standard strut depths
- For use in indoor, outdoor and mildly corrosive environments



Part Number	Thread Size	A	B	C	F1 Max. Rec. Load (lbs)	F2 Max. Rec. Load (lbs)	Recommended Torque
SLICK250	1/4 - 20	1-11/16"	1-1/8"	7/8"	200	800	5 ft. lbs.
SLICK375	3/8 - 16	1-11/16"	1-1/8"	7/8"	450	1100	15 ft. lbs.
SLICK500	1/2 - 13	1-11/16"	1-1/8"	7/8"	550	1250	20 ft. lbs.

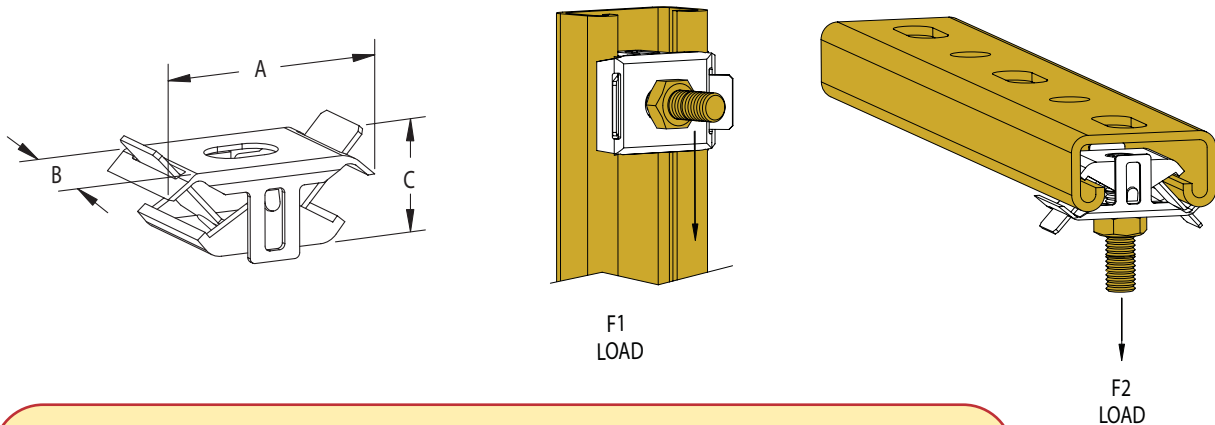

Features

- Installs with one hand
- No more hard-to-handle spring nuts
- Reduce installation time and inventory by over 75%
- Integral plastic strip provides tension to grip the strut, even vertically
- Allows for easy repositioning or removal



CADDY® CHANNEL CLAMP STS (STRUT-TO-STRUT)



Strut-to-Strut Clamp

- Surface Finish: Electro-zinc plated
- Provides fast assembly of back-to-back half-slot strut as an alternative to welded strut
- Unique one-piece assembly eliminates the need for washers, bolts and nuts
- For new or retrofit applications
- Allows joining of dissimilar half-slot channel, regardless of profile size or finish
- Easy installation with a 1/2" nut driver

Part Number	A	B	C	Max. Working Load (lbs)	Recommended Torque
STS	1.00"	1/2"	1-1/4"	1000	5 ft. lbs.

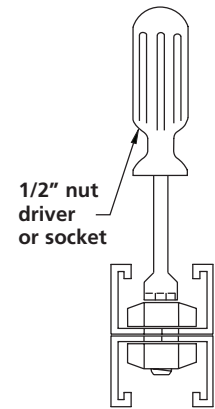

*1000 lbs working load per total assembly (5:1 safety factor). Not to exceed 1000 lbs. Half-slot dimensions vary by manufacturer. Minimum half-slot dimensions 9/16" x 7/8". Strut type and structure need to be evaluated to establish load for assembly. Use 1 STS per 1 ft. of strut, minimum of 2 required.

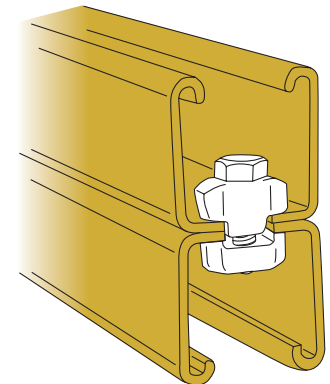
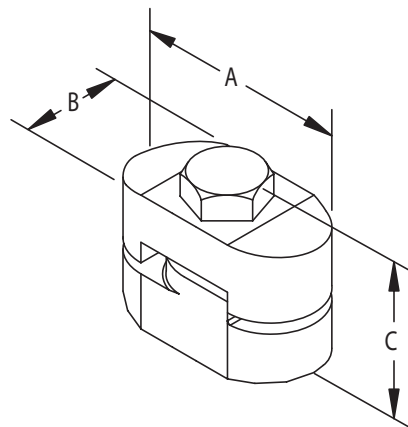

CHANNEL NUT NUT

Without Spring

- Size Range: #8, #10, 1/4", 5/16", 3/8", 1/2", 5/8", 3/4" and 7/8" thread sizes
- Surface Finish: Electro-zinc plated
- Fits 'A', 'B', 'D', 'E' and 'M' channels
- Also available in 304 Stainless Steel for 1/4", 3/8" and 1/2" sizes

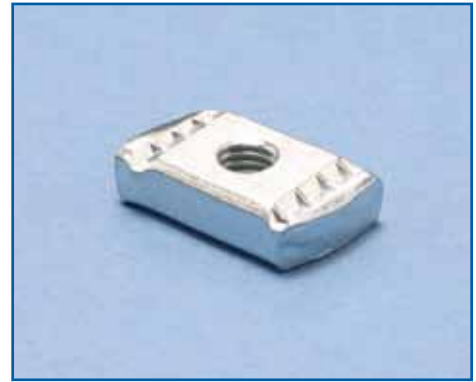

Part Number	Thread Size	A	B	C
NUT0008EG	#8 – 32	1-3/8"	3/4"	1/4"
NUT0010EG	#10 – 24	1-3/8"	3/4"	1/4"
NUT0025EG	1/4" – 20	1-3/8"	3/4"	1/4"
NUT0031EG	5/16" – 18	1-3/8"	3/4"	1/4"
NUT0037EG	3/8" – 16	1-3/8"	3/4"	3/8"
NUT0050EG	1/2" – 13	1-3/8"	3/4"	1/2"
NUT0062EG	5/8" – 11	1-3/8"	1-1/8"	1/2"
NUT0075EG	3/4" – 10	1-3/8"	1-1/8"	1/2"
NUT0087EG	7/8" – 9	1-3/8"	1-1/8"	1/2"

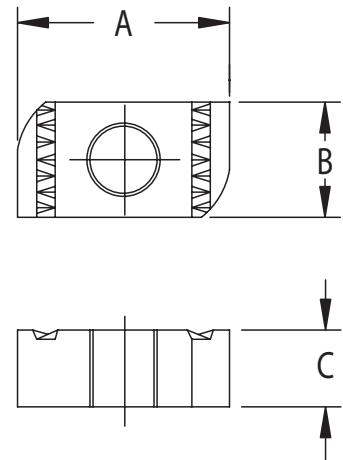

CHANNEL NUT NUTC

Without Spring

- Size Range: 1/2", 5/8", 3/4" and 7/8" thread sizes
- Surface Finish: Electro-zinc plated
- Fits 'C' channel
- Also available in 304 Stainless Steel for 1/4", 3/8" and 1/2" sizes



Part Number	Thread Size	A	B	C
NUTC0050EG	1/2 - 13	1-3/8"	3/4"	3/8"
NUTC0062EG	5/8 – 11	1-3/8"	1-1/8"	3/8"
NUTC0075EG	3/4 - 10	1-3/8"	1-1/8"	3/8"
NUTC0087EG	7/8 – 9	1-3/8"	1-1/8"	3/8"

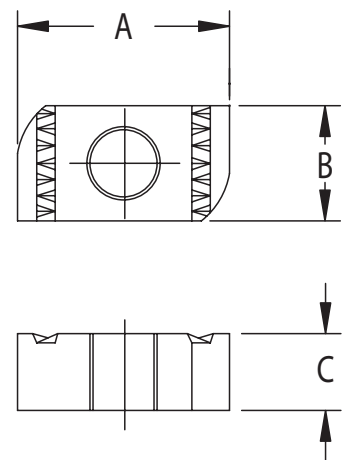

CHANNEL NUT SPRA

Spring Nut

- Size Range: #8, #10, 1/4", 5/16", 3/8", 1/2", 5/8", 3/4" and 7/8" thread sizes
- Surface Finish: Electro-zinc plated
- Fits 'A', 'B', and 'M' channels
- Also available in 304 Stainless Steel for 1/4", 3/8" and 1/2" sizes



Part Number	Thread Size	A	B	C
SPRA0008EG	#8 – 32	1-3/8"	3/4"	1/4"
SPRA0010EG	#10 – 24	1-3/8"	3/4"	1/4"
SPRA0025EG	1/4 - 20	1-3/8"	3/4"	1/4"
SPRA0031EG	5/16 – 18	1-3/8"	3/4"	1/4"
SPRA0037EG	3/8 – 16	1-3/8"	3/4"	3/8"
SPRA0050EG	1/2 - 13	1-3/8"	3/4"	1/2"
SPRA0062EG	5/8 – 11	1-3/8"	1-1/8"	1/2"
SPRA0075EG	3/4 - 10	1-3/8"	1-1/8"	1/2"
SPRA0087EG	7/8 – 9	1-3/8"	1-1/8"	1/2"

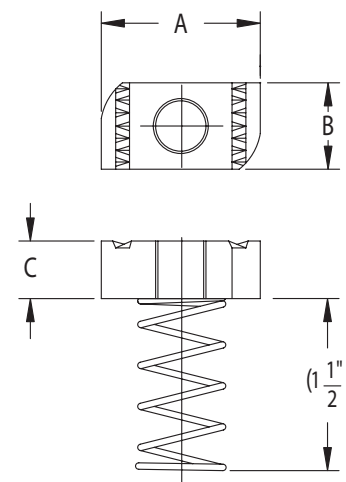

CHANNEL NUT SPRC

Spring Nut

- Size Range: #8, #10, 1/4", 5/16", 3/8", 1/2", 5/8", 3/4" and 7/8" thread sizes
- Surface Finish: Electro-zinc plated
- Fits 'C' & 'M' channels
- Also available in 304 Stainless Steel for 1/4", 3/8" and 1/2" sizes



Part Number	Thread Size	A	B	C
SPRC0008EG	#8 – 32	1-3/8"	3/4"	1/4"
SPRC0010EG	#10 – 24	1-3/8"	3/4"	1/4"
SPRC0025EG	1/4 - 20	1-3/8"	3/4"	1/4"
SPRC0031EG	5/16 – 18	1-3/8"	3/4"	1/4"
SPRC0037EG	3/8 – 16	1-3/8"	3/4"	3/8"
SPRC0050EG	1/2 - 13	1-3/8"	3/4"	3/8"
SPRC0062EG	5/8 – 11	1-3/8"	1-1/8"	3/8"
SPRC0075EG	3/4 - 10	1-3/8"	1-1/8"	3/8"
SPRC0087EG	7/8 – 9	1-3/8"	1-1/8"	3/8"

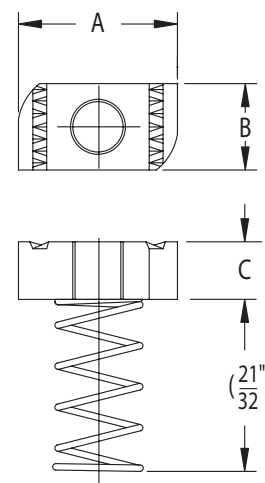

CHANNEL NUT SPRD

Spring Nut

- Size Range: #8, #10, 1/4", 5/16", 3/8", 1/2", 5/8" and 3/4" thread sizes
- Surface Finish: Electro-zinc plated
- Fits 'D' and 'E' channels



Part Number	Thread Size	A	B	C
SPRD0025EG	1/4 - 20	1-3/8"	3/4"	1/4"
SPRD0037EG	3/8 - 16	1-3/8"	3/4"	3/8"
SPRD0050EG	1/2 - 13	1-3/8"	1-1/8"	1/2"
SPRD0062EG	5/8 - 11	1-3/8"	1-1/8"	1/2"
SPRD0075EG	3/4 - 10	1-3/8"	1-1/8"	1/2"

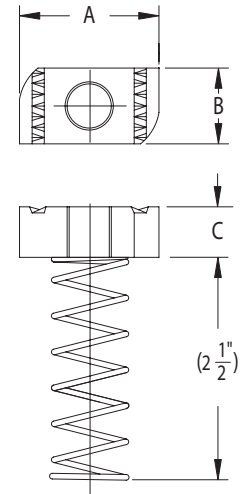

CHANNEL NUT SPRM

Spring Nut with Stud

- Size Range: 1/4", 5/16", 3/8", 1/2" and 5/8" thread sizes
- Surface Finish: Electro-zinc plated
- Fits 'A', 'B', and 'M' channels



Part Number	Thread Size	Stud Length	A	B	C
SPRM2508EG	1/4 - 20	7/8"	1-3/8"	3/4"	1/4"
SPRM2511EG	1/4 - 20	1-1/8"	1-3/8"	3/4"	1/4"
SPRM2515EG	1/4 - 20	1-1/2"	1-3/8"	3/4"	1/4"
SPRM3708EG	3/8 - 16	7/8"	1-3/8"	3/4"	3/8"
SPRM3711EG	3/8 - 16	1-1/8"	1-3/8"	3/4"	3/8"
SPRM3716EG	3/8 - 16	1-5/8"	1-3/8"	3/4"	3/8"
SPRM3718EG	3/8 - 16	1-7/8"	1-3/8"	3/4"	3/8"
SPRM3721EG	3/8 - 16	2-1/8"	1-3/8"	3/4"	3/8"
SPRM5011EG	1/2 - 13	1-1/8"	1-3/8"	3/4"	1/2"
SPRM5013EG	1/2 - 13	1-3/8"	1-3/8"	3/4"	1/2"

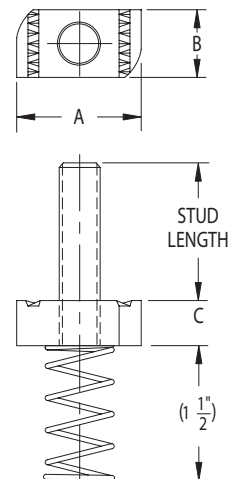

CHANNEL NUT TSNT

Top Spring Nut

- Size Range: 1/4", 3/8" and 1/2" thread sizes
- Surface Finish: Electro-zinc plated
- Fits 'A', 'B', 'C', 'D', 'E' and 'M' channels

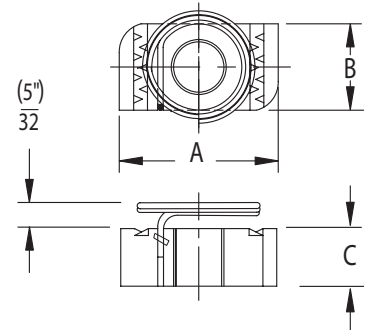

Part Number	Thread Size	A	B	C
TSNT0025EG	1/4 - 20	1-3/8"	3/4"	1/4"
TSNT0037EG	3/8 - 16	1-3/8"	3/4"	3/8"
TSNT0050EG	1/2 - 13	1-3/8"	3/4"	1/2"

Fastener Size	1/4-20	5/16-18	3/8-16	1/2-13
Foot-lbs	6	11	19	50
Nm	(8)	(15)	(26)	(68)

RESISTANCE TO SLIP

Thread Size	Part Number	Channel Size	12 GA (lbs)	14 GA (lbs)	16 GA (lbs)
#8 - 32	NUT, NUTC, SPRA, SPRC, SPRD	A, B, C, D, E, M	50	50	50
#10 - 24	NUT, NUTC, SPRA, SPRC, SPRD	A, B, C, D, E, M	100	100	100
1/4 - 20	NUT, NUTC, SPRA, SPRC, SPRD, TSNT	A, B, C, D, E, M	300	300	300
5/16 - 18	NUT, NUTC, SPRA, SPRC, SPRD	A, B, C, D, E, M	450	450	450
3/8 - 16	NUT, NUTC, SPRA, SPRC, SPRD, TSNT	A, B, C, D, E, M	800	800	800
1/2 - 13	NUT, NUTC, SPRA, SPRC, SPRD, TSNT	A, B, C, M	1500	1000	1000
5/8 - 11	NUT, NUTC, SPRA, SPRC, SPRD	D, E	1500	1000	1000
3/4 - 10	NUT, NUTC, SPRA, SPRC, SPRD	A, B, C, M	1500	1000	1000
7/8 - 9	NUT, NUTC, SPRA, SPRC, SPRD	D, E	1500	1000	1000

PULL OUT STRENGTH

Thread Size	Part Number	Channel Size	12 GA (lbs)	14 GA (lbs)	16 GA (lbs)
#8 - 32	NUT, NUTC, SPRA, SPRC, SPRD	A, B, C, D, E, M	200	200	200
#10 - 24	NUT, NUTC, SPRA, SPRC, SPRD	A, B, C, D, E, M	250	250	250
1/4 - 20	NUT, NUTC, SPRA, SPRC, SPRD, TSNT	A, B, C, D, E, M	450	450	450
5/16 - 18	NUT, NUTC, SPRA, SPRC, SPRD	A, B, C, D, E, M	750	750	750
3/8 - 16	NUT, NUTC, SPRA, SPRC, SPRD, TSNT	A, B, C, D, E, M	1100	1000	1000
1/2 - 13	NUT, NUTC, SPRA, SPRC, SPRD, TSNT	A, B, C, M	2000	1400	1000
1/2 - 13	NUT, NUTC, SPRA, SPRC, SPRD, TSNT	D, E	1500	1400	1000
5/8 - 11	NUT, NUTC, SPRA, SPRC, SPRD	A, B, C, M	2000	1400	1000
5/8 - 11	NUT, NUTC, SPRA, SPRC, SPRD	D, E	1500	1400	1000
3/4 - 10	NUT, NUTC, SPRA, SPRC, SPRD	A, B, C, M	2000	1400	1000
3/4 - 10	NUT, NUTC, SPRA, SPRC, SPRD	D, E	1500	1400	1000
7/8 - 9	NUT, NUTC, SPRA, SPRC, SPRD	A, B, C, M	2000	1400	1000
7/8 - 9	NUT, NUTC, SPRA, SPRC, SPRD	D, E	1500	1400	1000

HARDWARE NUT SQNT

Square Nut

- Size Range: 1/4", 3/8", 1/2" and 5/8" thread sizes
- Surface Finish: Electro-zinc plated

Part Number	Thread Size
SQNT0025EG	1/4 - 20
SQNT0037EG	3/8 - 16
SQNT0050EG	1/2 - 13
SQNT0062EG	5/8 - 11



VERTICAL ROD STIFFENER VS

Threaded Rod Support

- Size Range: 1/2" rod size
- Surface Finish: Electro-zinc plated
- Fits 'A', 'B', 'D', and 'E' channels

Part Number	Thread Size	A	B	C
VS0050EG	1/2 - 13	1-3/8"	13/16"	1-5/8"

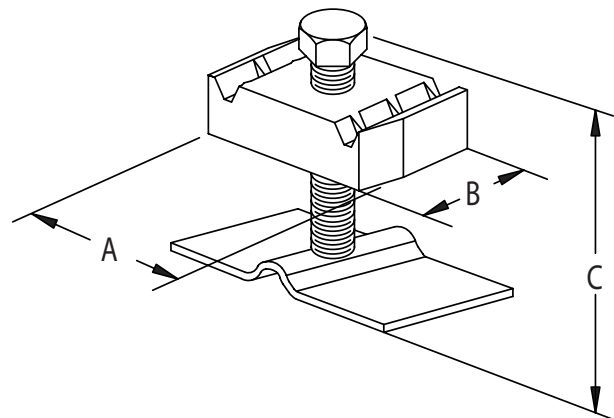
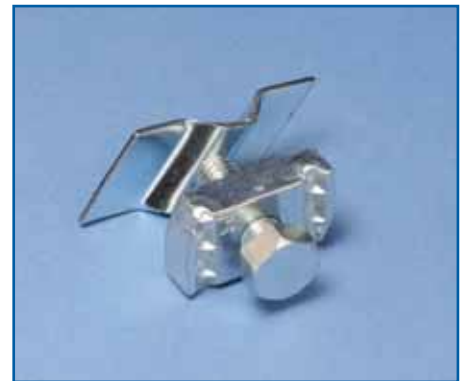

STRUT BEAM CLAMP STCB

Channel to Beam Clamp STCB

- Size Range: 3/8" rod size
- Surface Finish: Electro-zinc plated
- Structural attachment to beams to support threaded rod and/or strut
- Maximum flange thickness: 3/4" when used with 1-5/8" strut and 1-5/8" when used with 13/16" strut



Part Number	RS	A	B	C	Max. Rec. Load (lbs.)*
STCB6	3/8-16	3-13/16"	1-15/16"	1-5/32"	400

* Load rating is per fastener

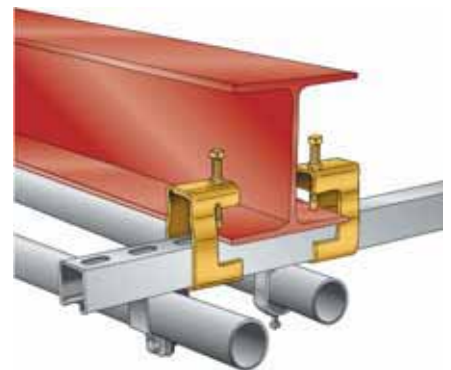
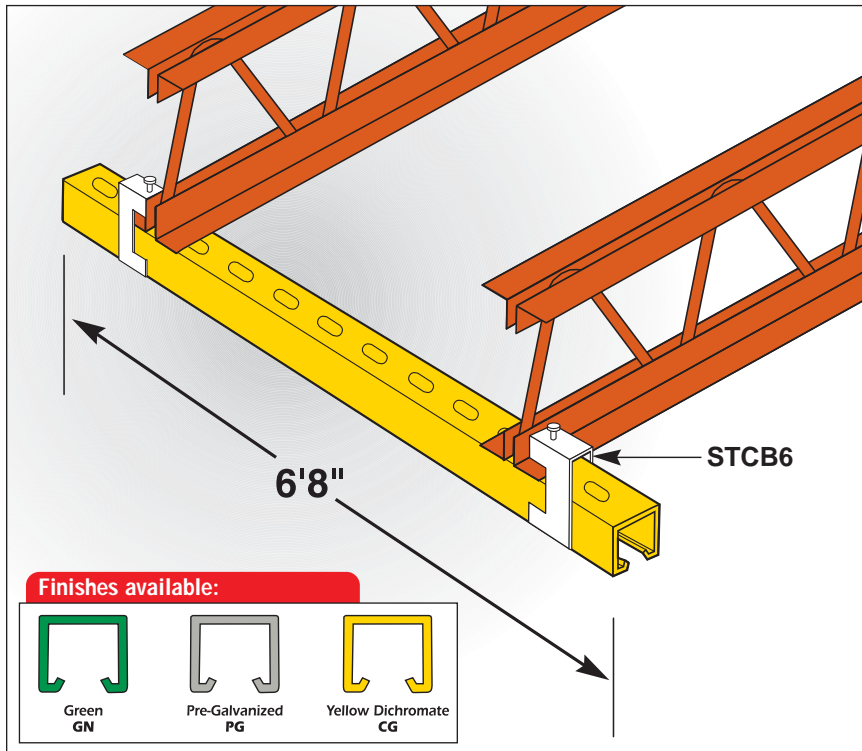

STRUT BEAM CLAMP BC16

Channel to Beam Clamp

- Surface Finish: Electro-zinc plated
- Structural attachment to beams to support strut
- Fits 'A' and 'D' channels

Part Number	A	B	C	Max. Rec. Load (lbs.)*
BC16A000EG	3-1/2"	3-1/2"	1-3/4"	900
BC16C000EG	2-11/16"	3-1/2"	15/16"	900

* When used in pairs

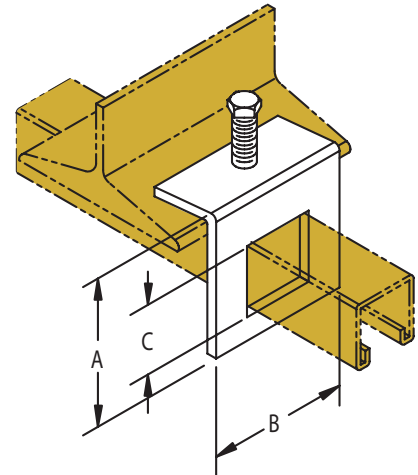

STRUT BEAM CLAMP BC17

Channel to Beam Clamp

- Surface Finish: Electro-zinc plated
- Structural attachment to beams to support strut
- Fits 'A' and 'D' channels

Part Number	A	B	Max. Rec. Load (lbs.)*
BC17A000EG	3-3/8"	3"	1200
BC17D000EG	5"	3"	1200

* When used in pairs

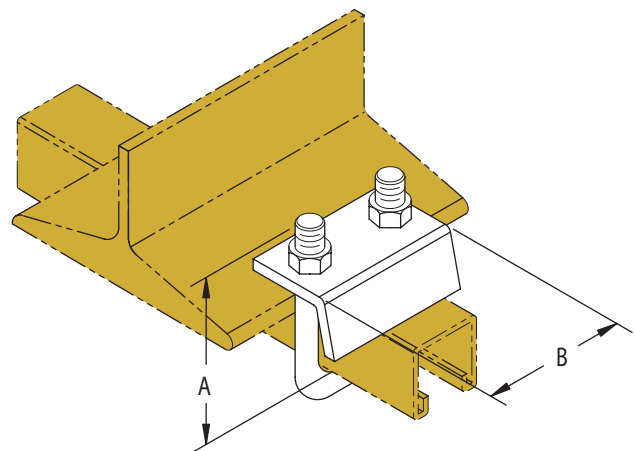

CHANNEL BRACKET BR22

Strut Bracket

- Surface Finish: Electro-zinc plated
- Strut bracket that attaches to strut
- Fits all standard strut depths

Part Number	A	B	Max. Rec. Uniform Load (lbs.)
BR220600EG	4-5/8"	6"	1800
BR221200EG	4-5/8"	12"	1000
BR221800EG	4-5/8"	18"	700
BR222400EG	4-5/8"	24"	500
BR223000EG	4-5/8"	30"	350
BR223600EG	4-5/8"	36"	300

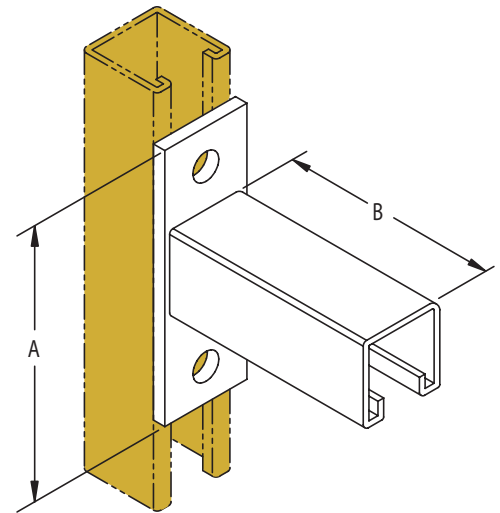

STRUT COVER

Closure Strip for Channels

- Fits all standard strut profiles
- Available in plastic, EG, Green and Cal-Gold color

Part Number	Color
CL100000EG	EG
CL100000PS	Plastic
CL100000GN	Green
CL100000CG	Cal-Gold

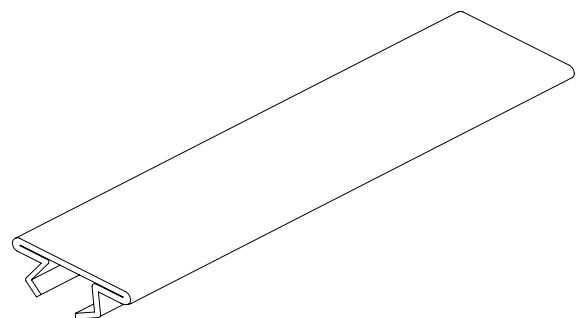

STRUT END CAPS ENDC

- Fits 'A', 'B', 'C', 'D', 'E' and 'M' strut profiles
- Surface Finish: Electro-zinc plated

Part Number	Strut GA	A
ENDCA120EG	A12	1-5/8"
ENDCA140EG	A14	1-5/8"
ENDCB120EG	B12	1-3/8"
ENDCC140EG	C14	13/16"
ENDCE120EG	E12	3-1/4"

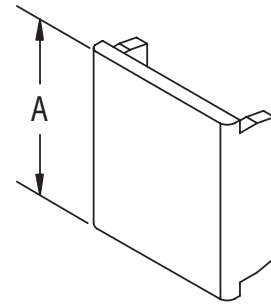
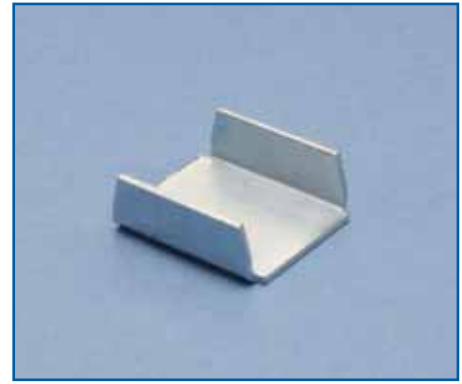

STRUT SPLICE PLATE F09

Two-hole Splice Plate

- Surface Finish: Electro-zinc plated

Part Number	A	B
F090000EG	3-1/2"	1-5/8"

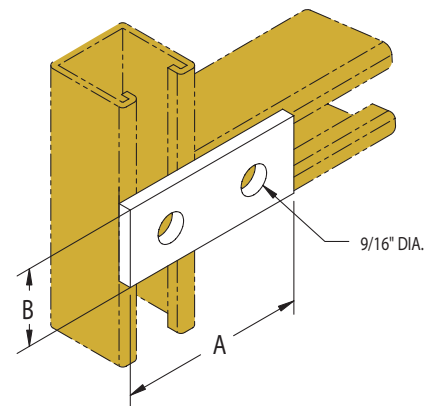
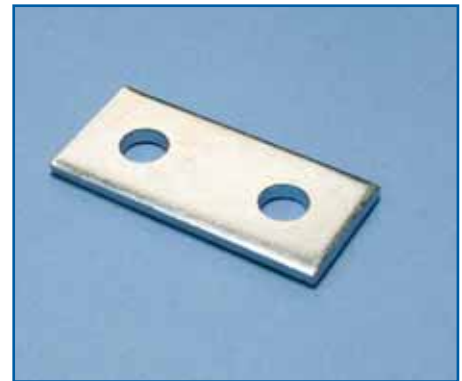

STRUT WASHER F10 – F12

Notched Channel Washer

- Surface Finish: Electro-zinc plated

Part Number	HS	Bolt Size
F100000EG	3/8"	5/16"
F110000EG	7/16"	3/8"
F120000EG	9/16"	1/2"
F120062EG	11/16"	5/8"
F120075EG	13/16"	3/4"

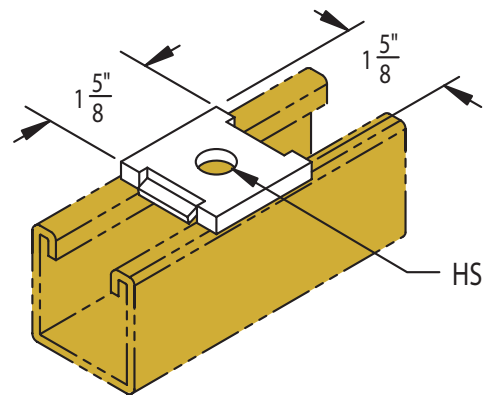
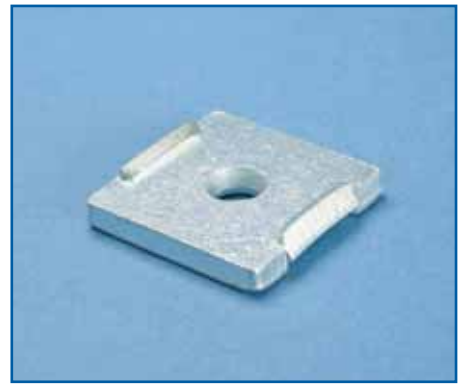

STRUT WASHER F13 – F18

Square Channel Washer

- Surface Finish: Electro-zinc plated

Part Number	HS	Bolt Size
F130000EG	3/8"	5/16"
F140000EG	7/16"	3/8"
F150000EG	9/16"	1/2"
F160000EG	11/16"	5/8"
F170000EG	13/16"	3/4"
F180000EG	15/16"	7/8"

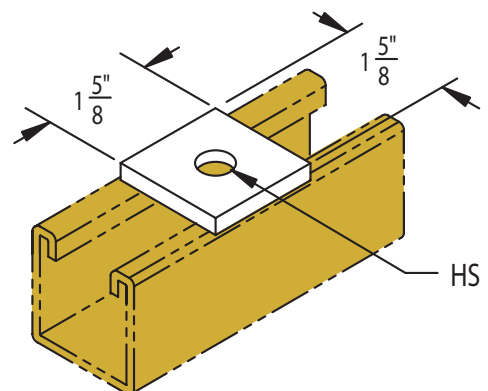
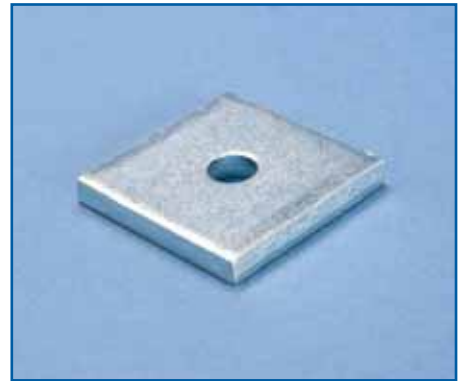

STRUT SPLICE PLATE F20

Three-hole Splice Plate

- Surface Finish: Electro-zinc plated

Part Number	A	B
F200000EG	5-3/8"	1-5/8"

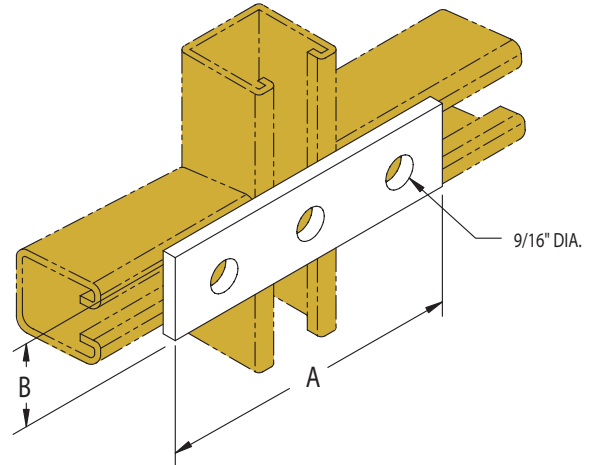
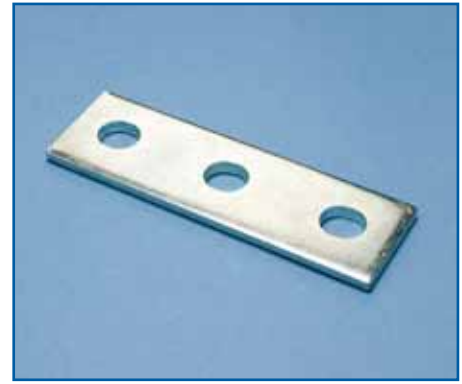

STRUT SPLICE PLATE F22

Two-hole Splice Plate

- Surface Finish: Electro-zinc plated

Part Number	A	B
F220000EG	3-1/4"	1-5/8"

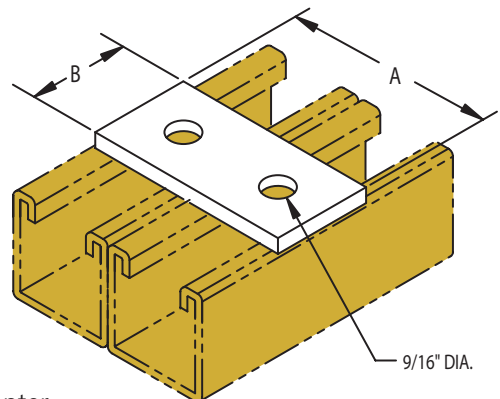

FITTING SPECIFICATIONS (unless noted otherwise):

Hole sizes 9/16", Spacing 13/16" from edge and 1-7/8" on center

Width 1-5/8", Thickness 1/4", Standard Finish: EG



STRUT SPLICE PLATE F23

Four-hole Splice Plate

- Surface Finish: Electro-zinc plated

Part Number	A	B
F230000EG	7-1/4"	1-5/8"

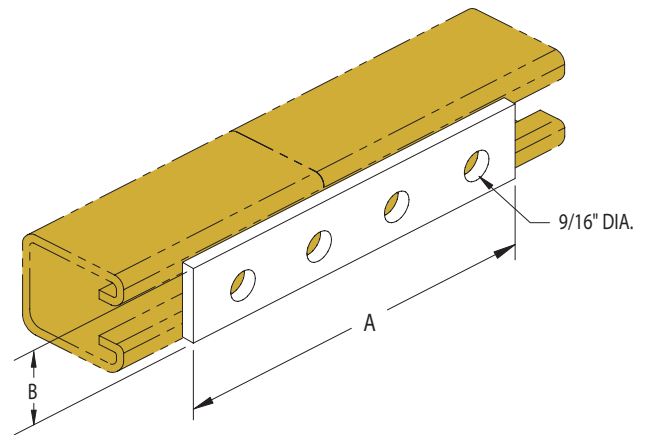

STRUT GUSSET PLATE F25

Four-hole Tee Gusset Plate

- Surface Finish: Electro-zinc plated

Part Number	A	B
F250000EG	5-3/8"	3-1/2"

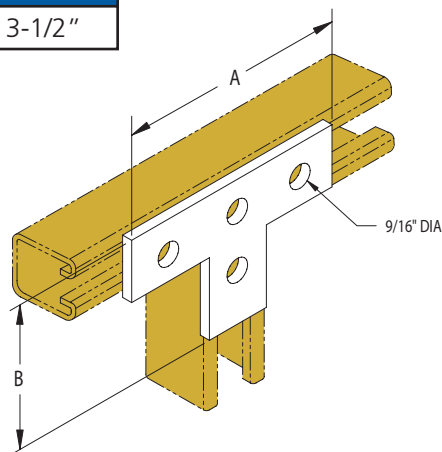
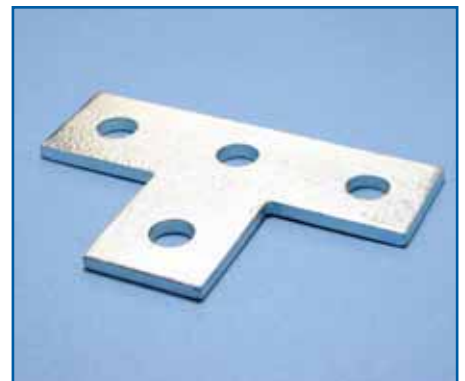

FITTING SPECIFICATIONS (unless noted otherwise):

Hole sizes 9/16", Spacing 13/16" from edge and 1-7/8" on center
 Width 1-5/8", Thickness 1/4", Standard Finish: EG

STRUT HALF TEE PLATE F36

Three-hole Half Tee Plate

- Surface Finish: Electro-zinc plated

Part Number	A	B
F360000EG	3-1/2"	3-1/2"

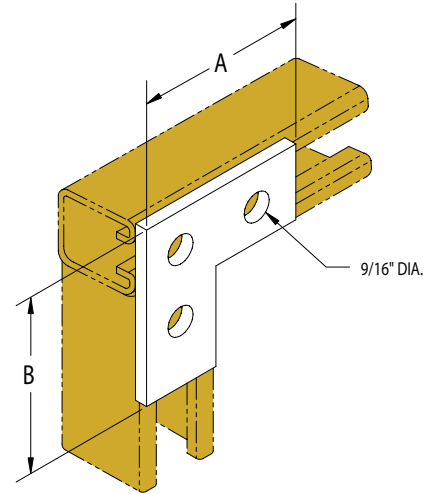

STRUT HALF TEE PLATE F37

Four-hole Half Tee Plate

- Surface Finish: Electro-zinc plated

Part Number	A	B
F370000EG	3-1/2"	5-3/8"

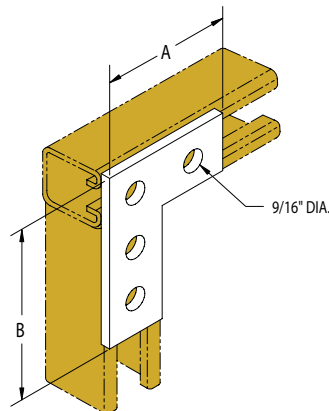

FITTING SPECIFICATIONS (unless noted otherwise):

Hole sizes 9/16", Spacing 13/16" from edge and 1-7/8" on center
 Width 1-5/8", Thickness 1/4", Standard Finish: EG



STRUT ANGLE L10

Two-hole Corner Angle

- Surface Finish: Electro-zinc plated

Part Number	A	B
L100000EG	2-1/4"	1-5/8"

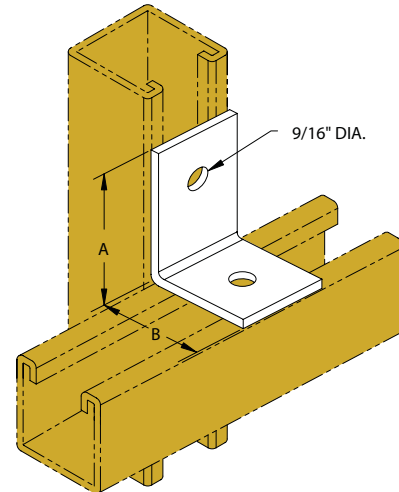

STRUT ANGLE L11

Two-hole Corner Angle

- Surface Finish: Electro-zinc plated

Part Number	A	B
L110000EG	2"	1-7/8"

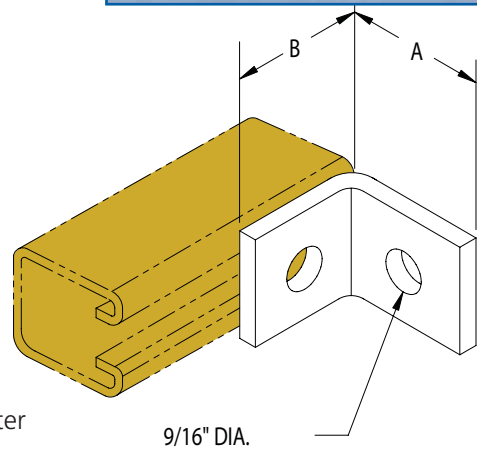

FITTING SPECIFICATIONS (unless noted otherwise):

- Hole sizes 9/16", Spacing 13/16" from edge and 1-7/8" on center
- Width 1-5/8", Thickness 1/4", Standard Finish: EG

STRUT ANGLE L12

Two-hole Corner Angle

- Surface Finish: Electro-zinc plated

Part Number	A	B
L120300EG	3"	1-7/8"
L120350EG	3-1/2"	1-7/8"
L120400EG	4"	1-7/8"

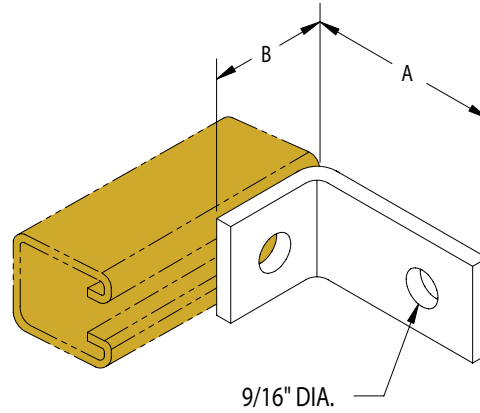
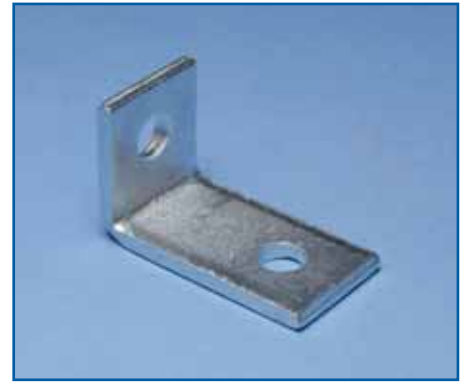

STRUT ANGLE L15

One-slot / One-hole Angle

- Surface Finish: Electro-zinc plated

Part Number	A	B
L150000EG	2-5/8"	1-5/8"

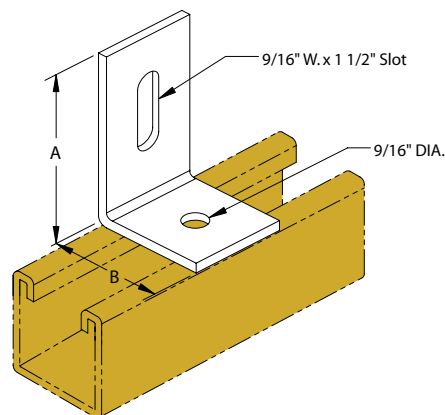
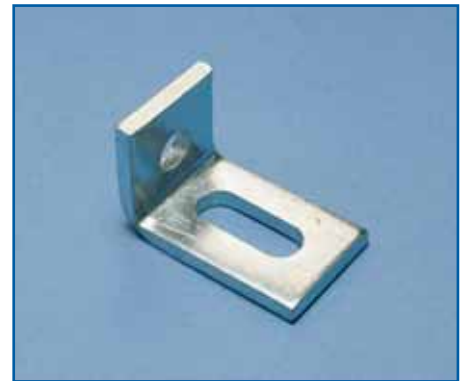

FITTING SPECIFICATIONS (unless noted otherwise):

Hole sizes 9/16", Spacing 13/16" from edge and 1-7/8" on center
 Width 1-5/8", Thickness 1/4", Standard Finish: EG



STRUT ANGLE L16 – L17

One-slot / One-hole Angle

- Surface Finish: Electro-zinc plated

Part Number	A	B	C
L160000EG	4-7/8"	1-7/8"	2-1/2"
L170000EG	6-7/8"	1-7/8"	4-1/4"

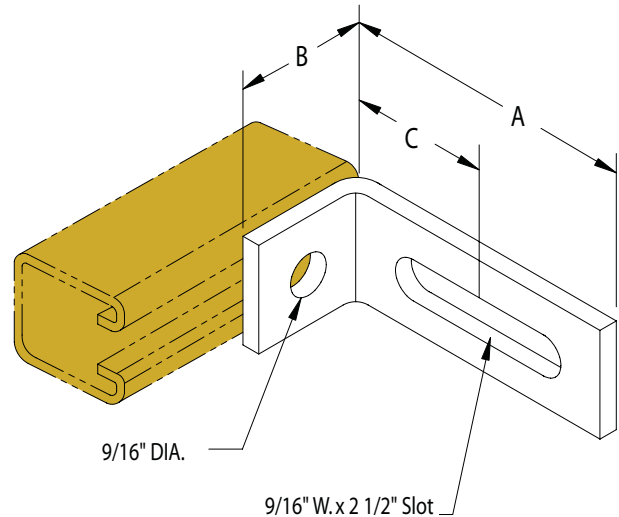

STRUT ANGLE L18

Three-hole Corner Angle

- Surface Finish: Electro-zinc plated

Part Number	A	B
L180000EG	3-1/2"	2-1/2"

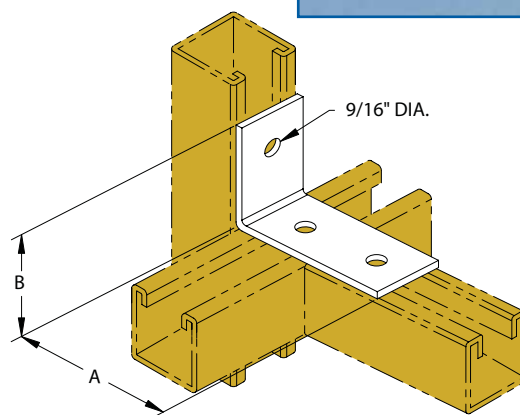

FITTING SPECIFICATIONS (unless noted otherwise):

Hole sizes 9/16", Spacing 13/16" from edge and 1-7/8" on center

Width 1-5/8", Thickness 1/4", Standard Finish: EG

STRUT ANGLE L19 – L20

Three-hole Corner Angle

- Surface Finish: Electro-zinc plated

Part Number	A	B
L190000EG	3-7/8"	1-7/8"
L200000EG	4-1/8"	1-5/8"

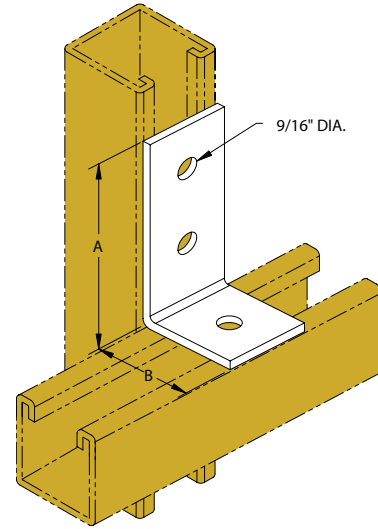
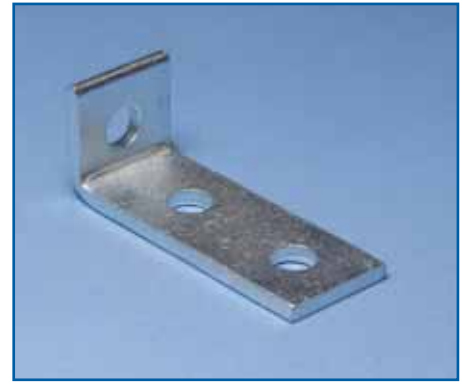

STRUT ANGLE L22

Four-hole Corner Angle

- Surface Finish: Electro-zinc plated

Part Number	A	B
L220000EG	4-1/8"	3-1/2"

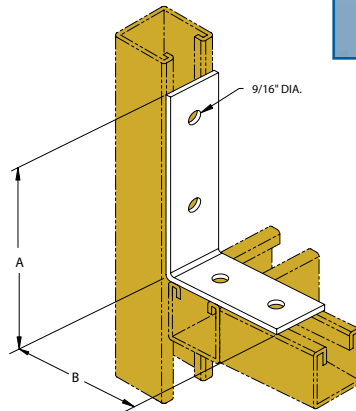
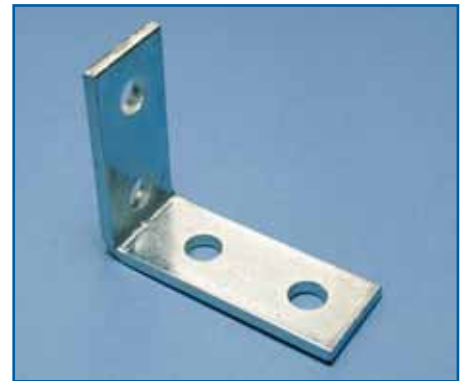

FITTING SPECIFICATIONS (unless noted otherwise):

Hole sizes 9/16", Spacing 13/16" from edge and 1-7/8" on center

Width 1-5/8", Thickness 1/4", Standard Finish: EG



STRUT ANGLE L23

Seven-hole Corner Angle

- Surface Finish: Electro-zinc plated

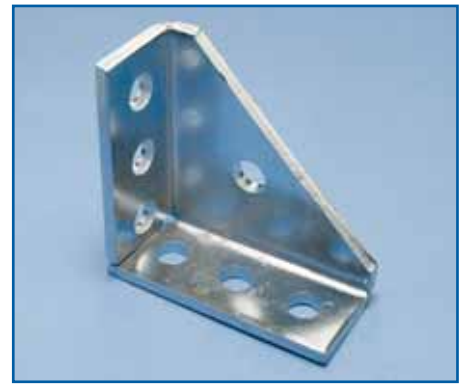

Part Number	A	B
L23U0000EG	4-1/8"	4-1/8"

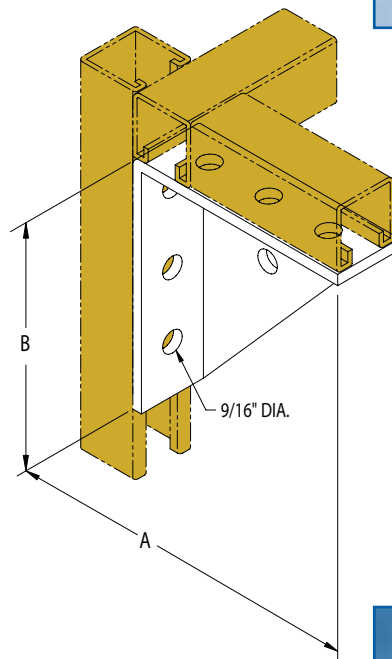

STRUT ANGLE L24

Six-hole Corner Angle

- Surface Finish: Electro-zinc plated
- Available for left or right hand use (right hand shown)

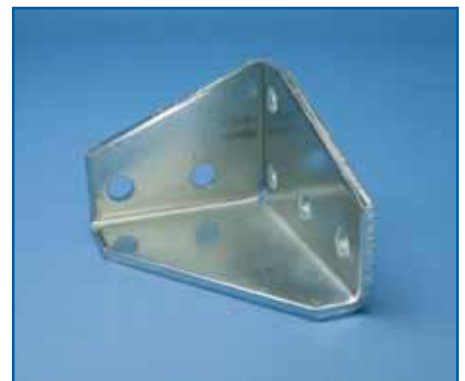

Part Number	A	B	C
L24L0000EG	5-3/8"	4-1/8"	3-1/2"
L24R0000EG	5-3/8"	4-1/8"	3-1/2"

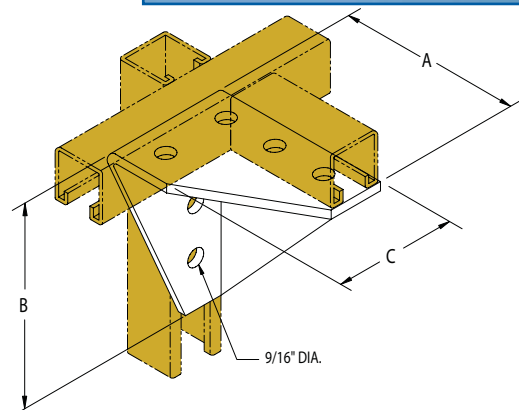

FITTING SPECIFICATIONS (unless noted otherwise):

Hole sizes 9/16", Spacing 13/16" from edge and 1-7/8" on center

Width 1-5/8", Thickness 1/4", Standard Finish: EG

STRUT ANGLE L25

Four-hole Offset Corner Angle

- Surface Finish: Electro-zinc plated
- Available for left or right hand use (right hand shown)

Part Number	A	B	C
L25L0000EG	3-3/4"	3-1/2"	1-7/8"
L25R0000EG	3-3/4"	3-1/2"	1-7/8"

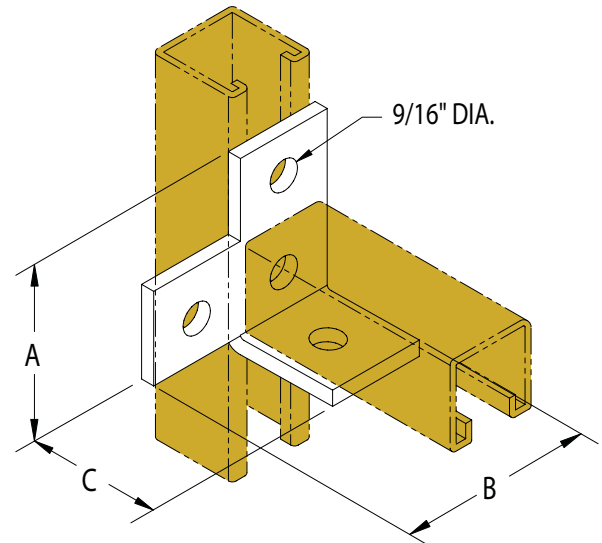
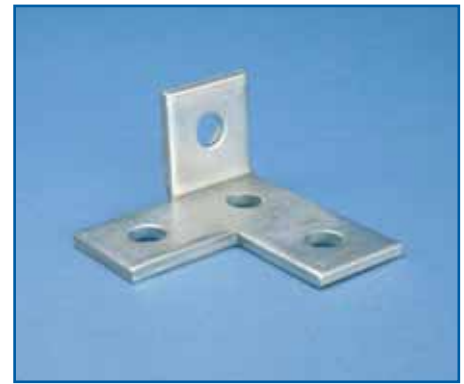

STRUT ANGLE L26

Three-hole Offset Corner Angle

- Surface Finish: Electro-zinc plated
- Available for left or right hand use (right hand shown)

Part Number	A	B
L26L0000EG	3-1/2"	2"
L26R0000EG	3-1/2"	2"

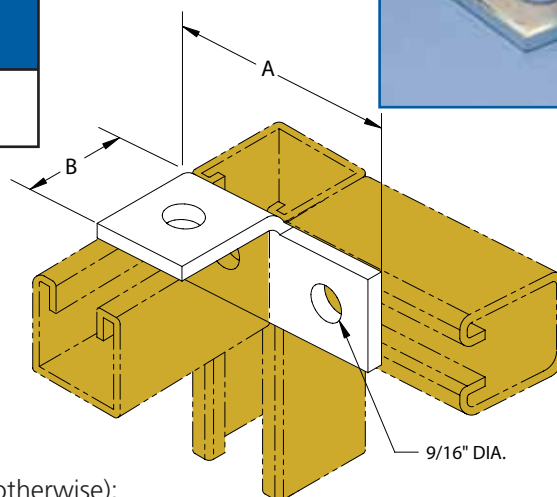
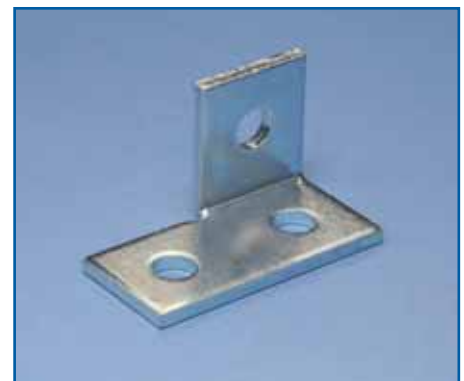

FITTING SPECIFICATIONS (unless noted otherwise):

Hole sizes 9/16", Spacing 13/16" from edge and 1-7/8" on center
 Width 1-5/8", Thickness 1/4", Standard Finish: EG



STRUT ANGLE L27

Four-hole Offset Corner Angle

- Surface Finish: Electro-zinc plated

Part Number	A	B
L270000EG	5-3/8"	1-15/16"

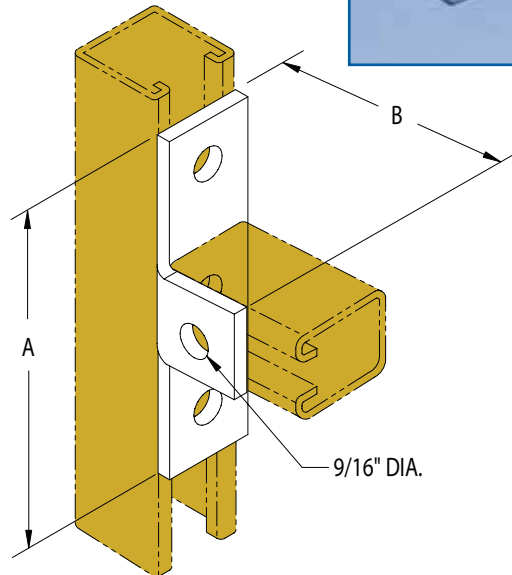

STRUT ANGLE L44

Two-hole 45° Angle

- Surface Finish: Electro-zinc plated

Part Number	A	B
L441200EG	12"	10-1/2"
L441600EG	16"	13-5/16"
L441800EG	18"	14-3/4"

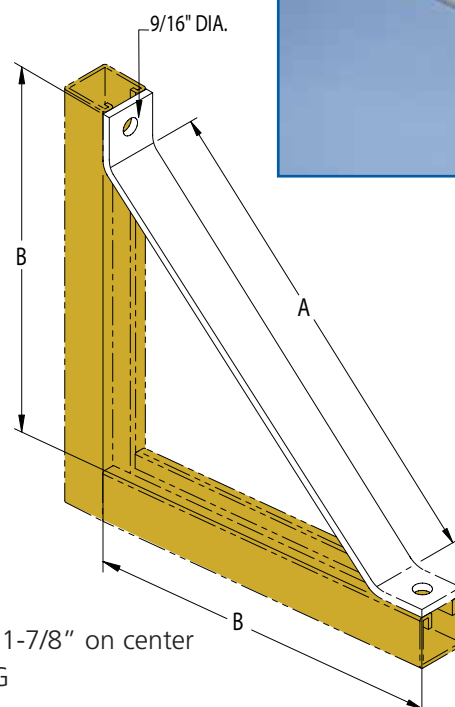

FITTING SPECIFICATIONS (unless noted otherwise):

Hole sizes 9/16", Spacing 13/16" from edge and 1-7/8" on center
 Width 1-5/8", Thickness 1/4", Standard Finish: EG

STRUT ANGLE L46

Two-hole Open Angle

- Surface Finish: Electro-zinc plated
- May be ordered with 'A' angle of 30°, 45° or 60°

Part Number	A	B	C
L460300EG	30°	3-3/16"	2-5/32"
L460450EG	45°	3-5/32"	2-1/4"
L460600EG	60°	3-3/32"	2-9/32"

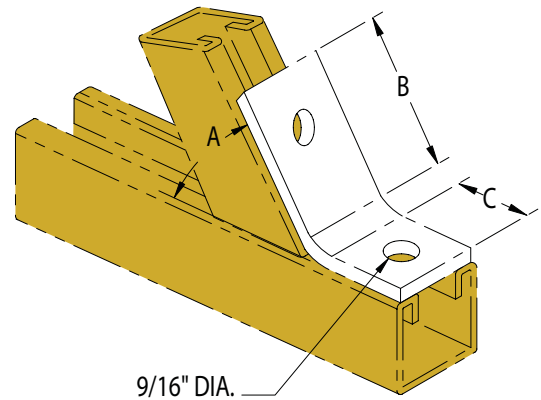
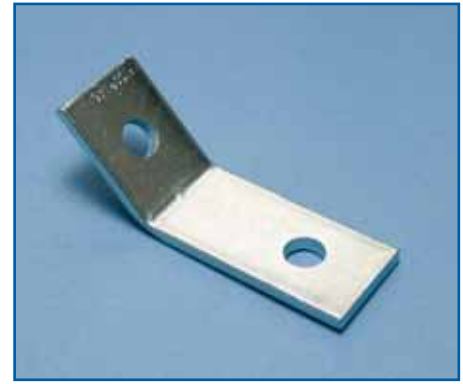

STRUT ANGLE L47

Two-hole Closed Angle

- Surface Finish: Electro-zinc plated
- May be ordered with 'A' angle of 30°, 45°, 60° or 82.5°

Part Number	A	B	C
L470300EG	30°	3-1/2"	2-1/2"
L470450EG	45°	3-1/2"	2-1/2"
L470600EG	60°	3-1/2"	2-1/2"
L470825EG	82.5°	3-1/2"	2-1/2"

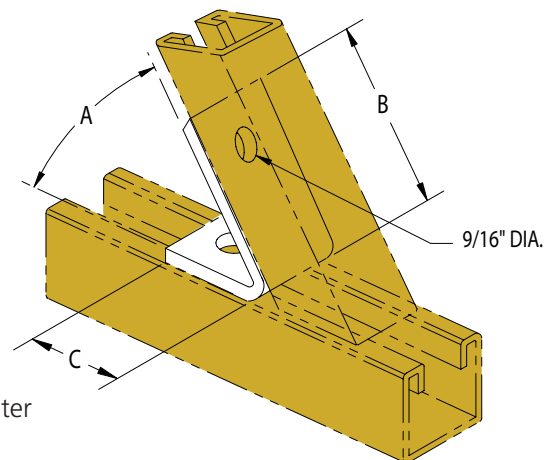

FITTING SPECIFICATIONS (unless noted otherwise):

Hole sizes 9/16", Spacing 13/16" from edge and 1-7/8" on center
Width 1-5/8", Thickness 1/4", Standard Finish: EG



STRUT POST BASE P09

Post Base for 'A' Channel

- Surface Finish: Electro-zinc plated

Part Number	A	B	C
P090000EG	6"	3-1/2"	3-1/2"

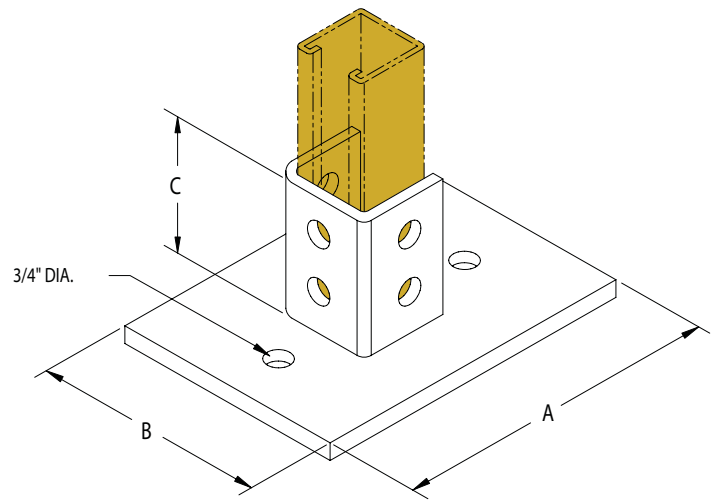

STRUT POST BASE P10

Post Base for 'A' Channel

- Surface Finish: Electro-zinc plated

Part Number	A	B	C
P100000EG	6"	6"	1-5/8"

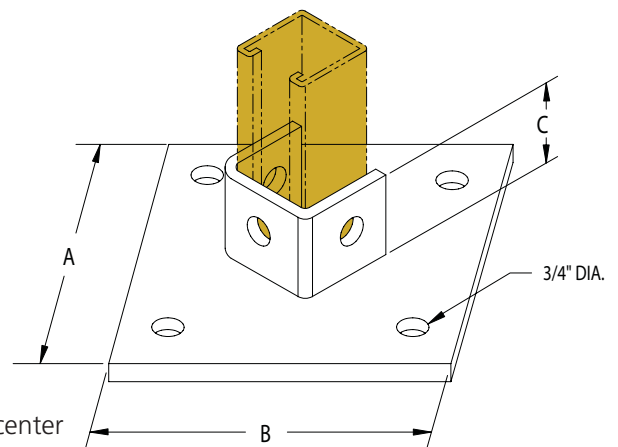
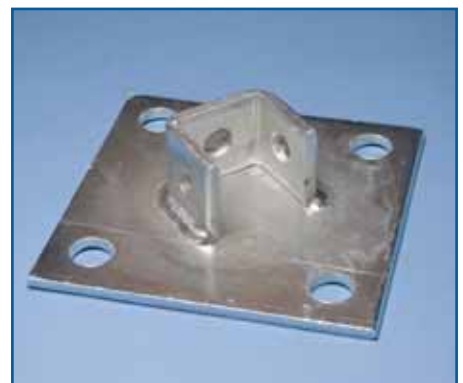

FITTING SPECIFICATIONS (unless noted otherwise):

Hole sizes 9/16", Spacing 13/16" from edge and 1-7/8" on center
 Width 1-5/8", Thickness 1/4", Standard Finish: EG

STRUT POST BASE P11

Post Base for 'A' Channel

- Surface Finish: Electro-zinc plated

Part Number	A	B	C
P110000EG	6"	6"	3-1/2"

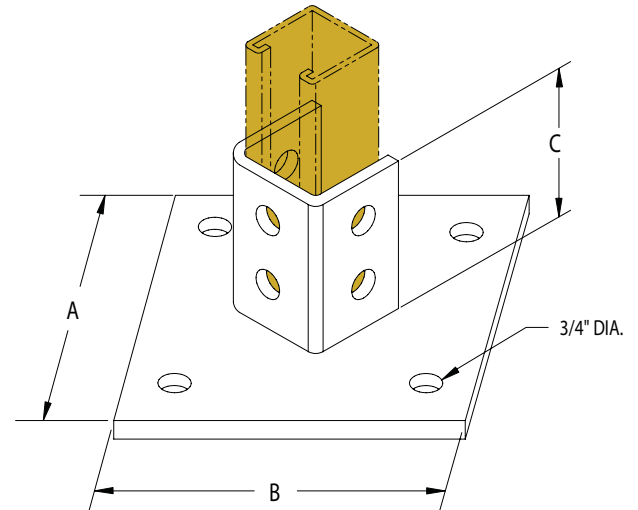
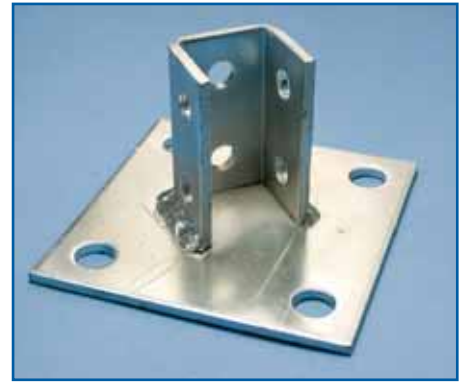

STRUT POST BASE P13

Post Base for Welded Channel

- Surface Finish: Electro-zinc plated

Part Number	A	B	C
P130000EG	6"	6"	3-1/2"

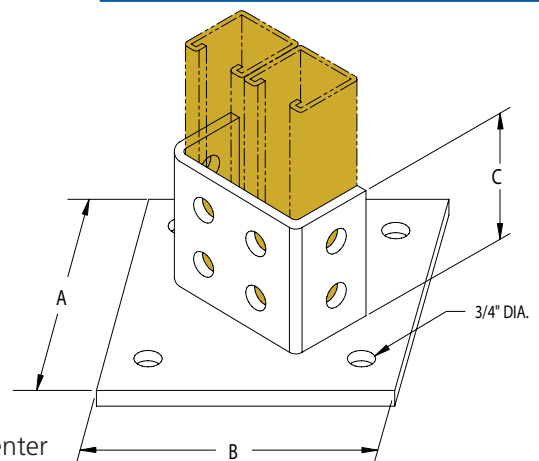
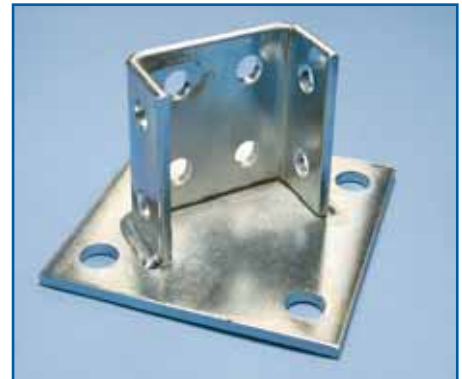

FITTING SPECIFICATIONS (unless noted otherwise):

Hole sizes 9/16", Spacing 13/16" from edge and 1-7/8" on center
 Width 1-5/8", Thickness 1/4", Standard Finish: EG



STRUT TROLLEY ROL10

Single Trolley

- Surface Finish: Electro-zinc plated
- For use with A12, A14, D12 or E12 channels
- Wheels: 1-3/8" diameter



Part Number	A	B
ROL10000EG	3-1/2"	1-5/8"

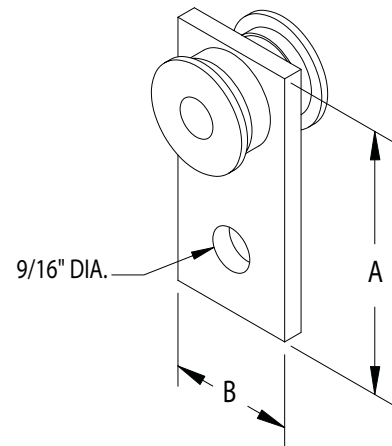

STRUT TROLLEY ROL11

Double Trolley

- Surface Finish: Electro-zinc plated
- For use with A12, A14, D12 or E12 channels
- Wheels: 1-3/8" diameter



Part Number	A	B
ROL11000EG	3-11/16"	3-1/2"

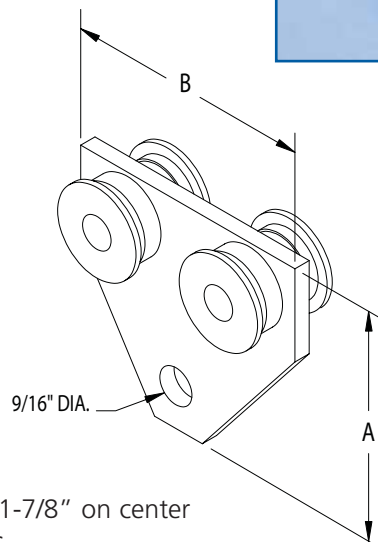

FITTING SPECIFICATIONS (unless noted otherwise):

Hole sizes 9/16", Spacing 13/16" from edge and 1-7/8" on center
 Width 1-5/8", Thickness 1/4", Standard Finish: EG

STRUT SUPPORT U10A

Three-hole Channel Support

- Surface Finish: Electro-zinc plated
- For use with 'A' channels

Part Number	A	B	C
U10A0000EG	5-3/8"	1-5/8"	1-3/4"

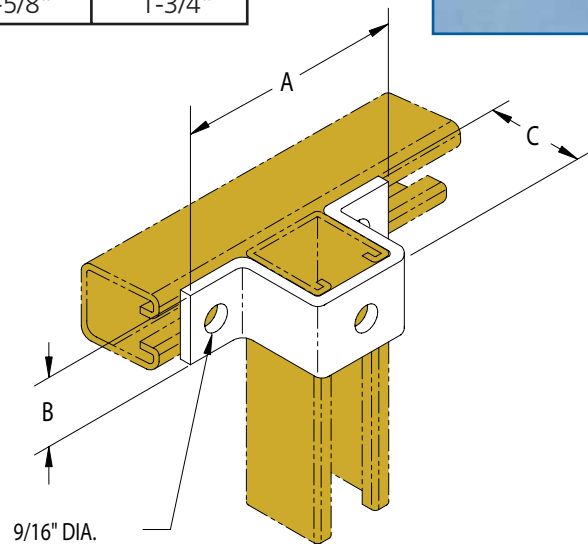
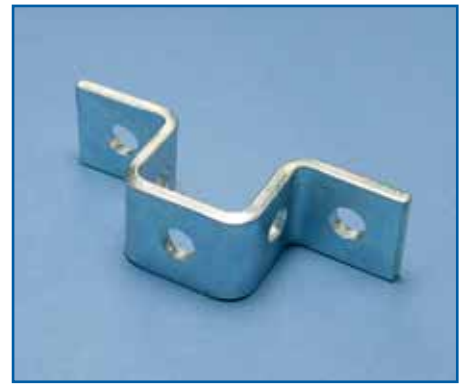

STRUT SPLICE U24

Four-hole Splice

- Surface Finish: Electro-zinc plated
- For use with 'A', 'C' and 'D' channels

Part Number	A	B	Channel Type
U24A0000EG	1-5/8"	7-1/4"	A
U24C0000EG	13/16"	7-1/4"	C
U24D0000EG	2-7/16"	7-1/4"	D

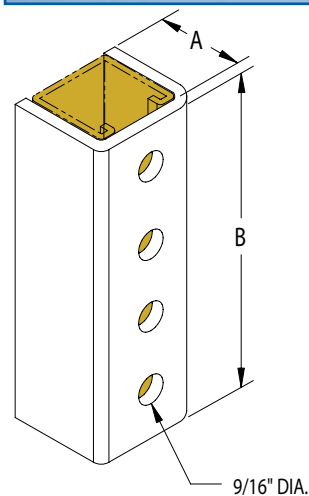

FITTING SPECIFICATIONS (unless noted otherwise):

Hole sizes 9/16", Spacing 13/16" from edge and 1-7/8" on center
 Width 1-5/8", Thickness 1/4", Standard Finish: EG



STRUT CORNER CONNECTOR W10

2-hole Single Corner Connector

- Surface Finish: Electro-zinc plated
- Available for left or right hand use (right hand shown)

Part Number	A	B	C
W10L0000EG	1-3/4"	3-1/2"	1-7/8"
W10R0000EG	1-3/4"	3-1/2"	1-7/8"

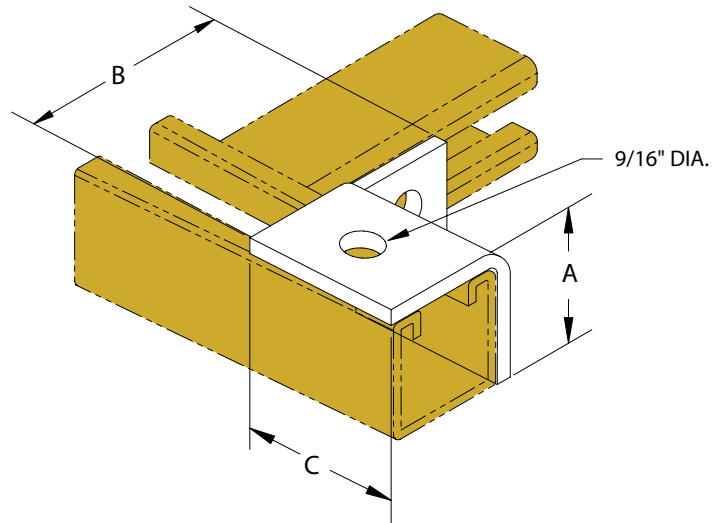
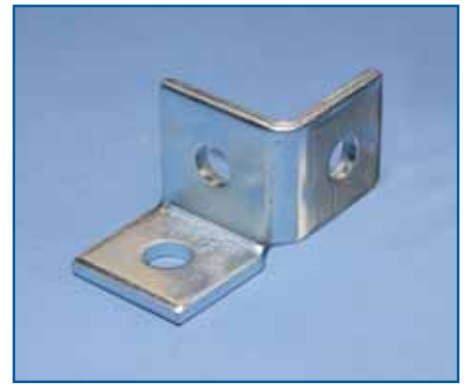

STRUT CORNER CONNECTOR W12

4-hole Double Corner Connector

- Surface Finish: Electro-zinc plated

Part Number	A	B	C
W120000EG	3-1/2"	3-1/2"	1-7/8"

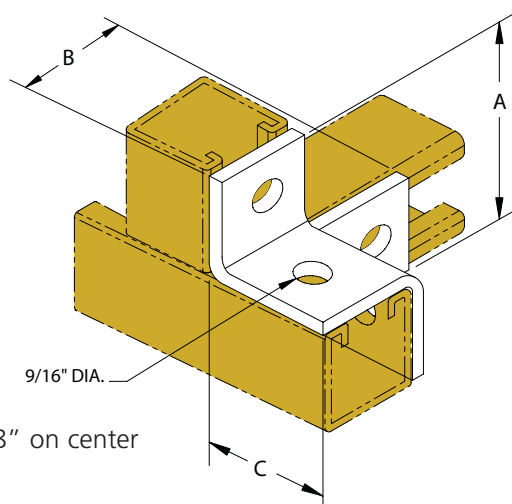
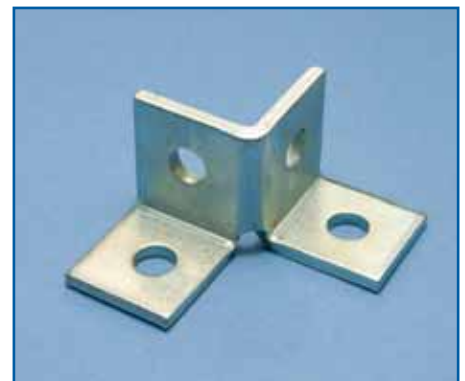

FITTING SPECIFICATIONS (unless noted otherwise):

Hole sizes 9/16", Spacing 13/16" from edge and 1-7/8" on center
 Width 1-5/8", Thickness 1/4", Standard Finish: EG

STRUT CORNER CONNECTOR W13

Six-hole Double Corner Connector

- Surface Finish: Electro-zinc plated

Part Number	A	B	C
W130000EG	3-3/4"	3-3/4"	3-7/8"

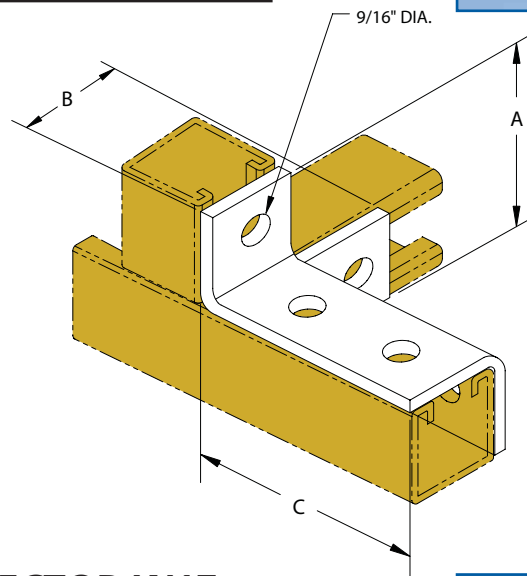
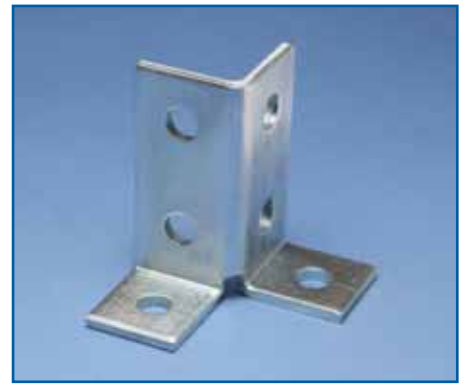

STRUT CORNER CONNECTOR W17

Eight-hole Double Corner Connector

- Surface Finish: Electro-zinc plated

Part Number	A	B	C
W170000EG	1-3/4"	5-13/32"	3-3/4"

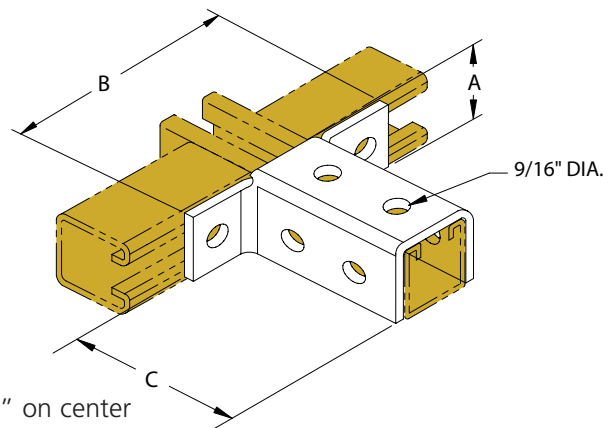

FITTING SPECIFICATIONS (unless noted otherwise):

Hole sizes 9/16", Spacing 13/16" from edge and 1-7/8" on center
 Width 1-5/8", Thickness 1/4", Standard Finish: EG



STRUT CORNER CONNECTOR W18

Ten-hole Double Corner Connector

- Surface Finish: Electro-zinc plated

Part Number	A	B	C
W180000EG	1-3/4"	9-5/32"	3-3/4"

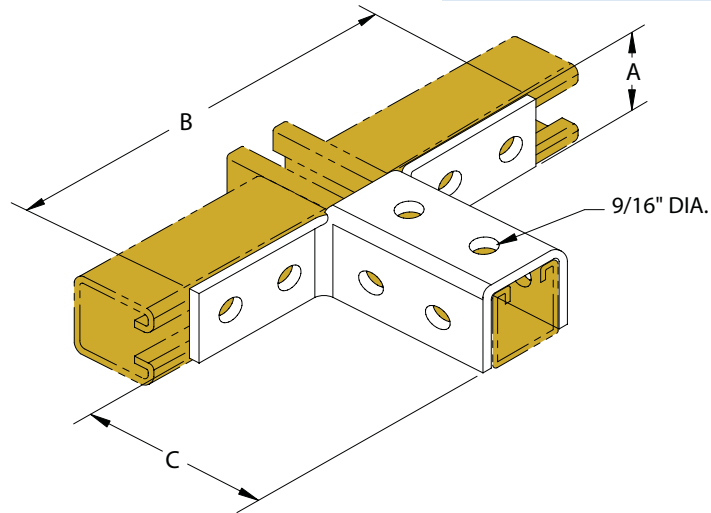

STRUT WING CONNECTOR W19

Six-hole Triple Wing Connector

- Surface Finish: Electro-zinc plated

Part Number	A	B	C
W190000EG	3-1/2"	5-7/16"	2"

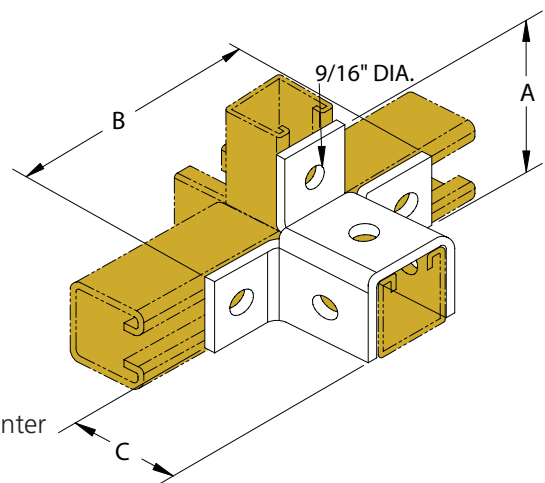
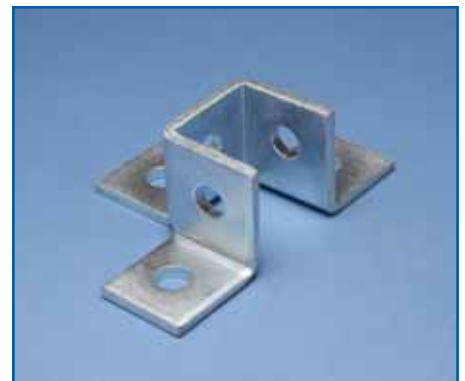

FITTING SPECIFICATIONS (unless noted otherwise):

Hole sizes 9/16", Spacing 13/16" from edge and 1-7/8" on center
 Width 1-5/8", Thickness 1/4", Standard Finish: EG

STRUT WING CONNECTOR W20

Nine-hole Triple Wing Connector

- Surface Finish: Electro-zinc plated

Part Number	A	B	C
W200000EG	3-1/2"	5-7/16"	3-3/4"

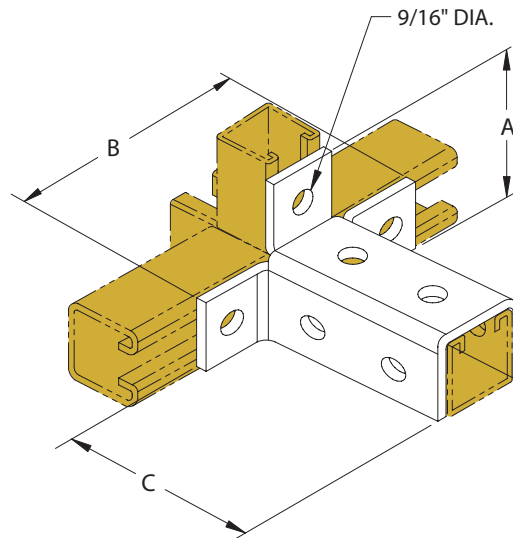

STRUT GUSSET CONNECTOR W23

Eight-hole Double Gusset Connector

- Surface Finish: Electro-zinc plated

Part Number	A	B	C
W230000EG	5-3/8"	5-3/8"	3-3/4"

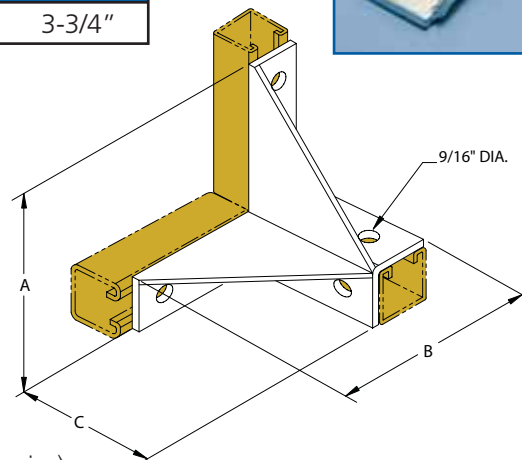

FITTING SPECIFICATIONS (unless noted otherwise):

Hole sizes 9/16", Spacing 13/16" from edge and 1-7/8" on center
 Width 1-5/8", Thickness 1/4", Standard Finish: EG





Page 210

105



Page 211

406



Page 212

305



Page 213

150



Page 214

OD



Page 215

RIGD

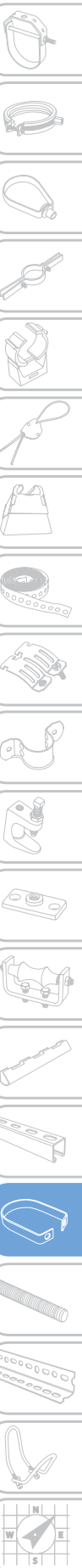

SWIVEL LOOP HANGER 105

304 Stainless Steel Band Hanger

- Size Range: 1/2" through 8"
- Recommended for the suspension of stationary stainless steel pipe lines
- Conforms with Federal Specification WW-H-171 (Type 10), Manufacturers Standardization Society (MSS) SP-58 and SP-69 (Type 10)



NOTE: Swivel nut not furnished with hanger.
Stainless steel hex nuts recommended for use with hanger

Part Number	Nominal Pipe Size	A	B	Max. Rec. Load (lbs.)
1050050S4	1/2"	7/16"	2-3/16"	610
1050075S4	3/4"	7/16"	3-1/16"	610
1050100S4	1"	7/16"	3-5/16"	610
1050125S4	1-1/4"	7/16"	3-5/8"	610
1050150S4	1-1/2"	7/16"	4"	610
1050200S4	2"	7/16"	4-3/8"	610
1050250S4	2-1/2"	9/16"	4-7/8"	970
1050300S4	3"	9/16"	5-1/2"	970
1050350S4	3-1/2"	9/16"	6"	970
1050400S4	4"	11/16"	6-1/2"	1250
1050500S4	5"	11/16"	7-9/16"	1250
1050600S4	6"	13/16"	8-5/8"	1600
1050800S4	8"	13/16"	10-5/8"	1800

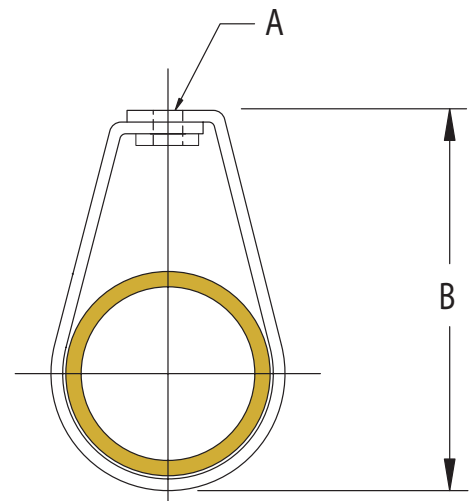

CLEVIS HANGER 406

Standard Duty 304 Stainless Steel

- Size Range: 1/2" through 24"
- Recommended for the suspension of stationary non-insulated stainless steel pipe lines
- Conforms with Federal Specification WW-H-171 (Type 1), Manufacturers Standardization Society (MSS) SP-58 and SP-69 (Type 1)



Part Number	Nominal Pipe Size	RS	A	B	Max. Rec. Load (lbs.)
4060050S4	1/2"	3/8	2-1/8"	1-5/8"	610
4060075S4	3/4"	3/8	2-3/8"	1-3/4"	610
4060100S4	1"	3/8	2-3/4"	2-1/16"	610
4060125S4	1-1/4"	3/8	3-5/16"	2-3/8"	610
4060150S4	1-1/2"	3/8	3-15/16"	2-15/16"	610
4060200S4	2"	3/8	4-1/2"	3-1/4"	610
4060250S4	2-1/2"	1/2	5-1/4"	3-1/4"	1130
4060300S4	3"	1/2	6"	4-1/8"	1130
4060350S4	3-1/2"	1/2	6-1/2"	4-7/16"	1130
4060400S4	4"	5/8	7-3/4"	5-3/8"	1130
4060500S4	5"	5/8	9-3/4"	6-13/16"	1430
4060600S4	6"	3/4	11-3/4"	8-1/4"	1940
4060800S4	8"	3/4	14"	9-1/2"	2000
4061000S4	10"	7/8	16-1/2"	10-7/8"	3600
4061200S4	12"	7/8	18-5/8"	12"	3800
4061400S4	14"	1	21-3/4"	14-1/2"	4200
4061600S4	16"	1	24"	15-3/4"	4600
4061800S4	18"	1-1/8	26-3/4"	17-1/2"	4800
4062000S4	20"	1-1/4	30"	19-5/8"	4800
4062400S4	24"	1-1/4	34-1/8"	21-3/4"	4800

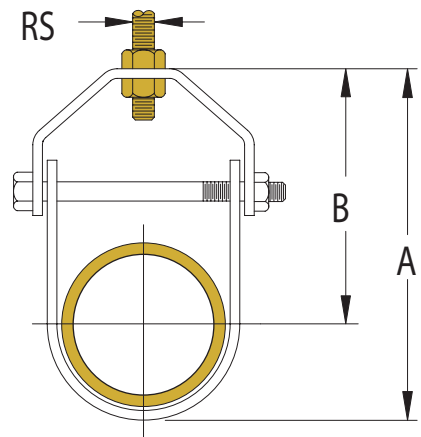

BEAM CLAMP 305

316 Stainless Steel Top Mount Beam Clamp

- Size Range: 3/8" and 1/2" rod sizes
- Structural attachment to top flange of metal beams, purlins, channel, or angle iron where the flange thickness does not exceed 5/8"
- Conforms with Federal Specification WW-H-171 (Type 23), Manufacturers Standardization Society ANSI/MSS-SP-58 (Type 19 & 23), install in accordance with ANSI/MSS-SP-69



NOTE: Set screw must be tightened and torqued to 60-inch pounds onto the sloped side of the I-beam, channel, or angle iron flange.

Part Number	RS	A	B	Set Screw	Max. Rec. Load (lbs.)
3050037S6	3/8"	3/4"	7/8"	3/8"	500
3050050S6	1/2"	3/4"	7/8"	3/8"	1130

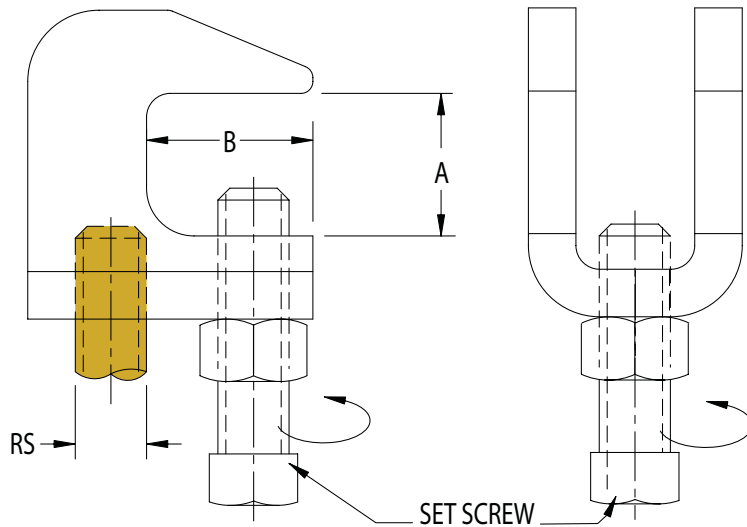

PIPE FIXINGS 150

304 Stainless Steel Standard U-bolt

- Size Range: 1/2" through 18"
- Pipe support for general piping applications
- Comes with two nuts installed on each end of U-bolt



Part Number	Nominal Pipe Size	RS	A	Max. Rec. Load (lbs.)
150M0050S4	1/2"	1/4"	3-1/2"	435
150M0075S4	3/4"	1/4"	3-9/16"	435
150M0100S4	1"	1/4"	3-11/16"	435
150M0125S4	1-1/4"	3/8"	4-1/8"	1090
150M0150S4	1-1/2"	3/8"	4-5/16"	1090
150M0200S4	2"	3/8"	4-13/16"	1090
150M0250S4	2-1/2"	1/2"	5-3/4"	2020
150M0300S4	3"	1/2"	6-5/16"	2020
150M0400S4	4"	1/2"	7-5/16"	2020
150M0500S4	5"	1/2"	8-5/16"	2020
150M0600S4	6"	5/8"	10-1/8"	3230
150M0800S4	8"	5/8"	12-1/8"	3230
150M1000S4	10"	3/4"	14-9/16"	4830
150M1200S4	12"	7/8"	16-15/16"	6730
150M1400S4	14"	7/8"	18-3/16"	6730
150M1600S4	16"	7/8"	20-3/16"	6730
150M1800S4	18"	1"	22-11/16"	8850

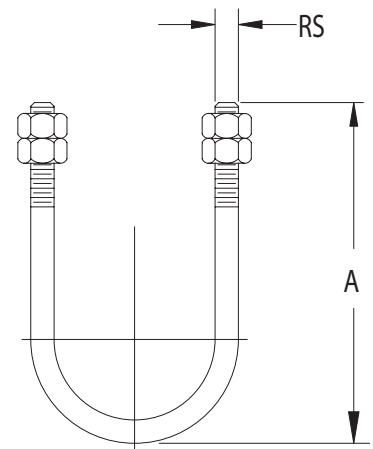

STRUT PIPE CLAMPS OD

304 Stainless Steel Four-piece Strut Clamps

- Size Range: 1/4" thru 8-5/8"
- Other sizes available upon request
- Four-piece design includes slotted hex head machine screw and square nut



Part Number	OD Size (in)	Strap GA	Max. Rec. Load (lbs.)
OD0025S4	1/4"	17GA	400
OD0037S4	3/8"	17GA	400
OD0050S4	1/2"	17GA	400
OD0062S4	5/8"	17GA	400
OD0075S4	3/4"	17GA	400
OD0087S4	7/8"	17GA	400
OD0100S4	1"	15GA	600
OD0112S4	1-1/8"	15GA	600
OD0125S4	1-1/4"	15GA	600
OD0137S4	1-3/8"	15GA	600
OD0150S4	1-1/2"	15GA	600
OD0162S4	1-5/8"	15GA	600
OD0175S4	1-3/4"	13GA	800
OD0187S4	1-7/8"	13GA	800
OD0200S4	2"	13GA	800
OD0212S4	2-1/8"	13GA	800
OD0225S4	2-1/4"	13GA	800
OD0237S4	2-3/8"	13GA	800
OD0250S4	2-1/2"	13GA	800
OD0262S4	2-5/8"	13GA	800
OD0275S4	2-3/4"	13GA	800
OD0287S4	2-7/8"	13GA	800
OD0300S4	3"	13GA	800
OD0312S4	3-1/8"	13GA	800
OD0325S4	3-1/4"	13GA	800
OD0337S4	3-3/8"	13GA	800
OD0350S4	3-1/2"	13GA	1000
OD0362S4	3-5/8"	12GA	1000
OD0375S4	3-3/4"	12GA	1000
OD0387S4	3-7/8"	12GA	1000
OD0400S4	4"	12GA	1000
OD0412S4	4-1/8"	12GA	1000
OD0425S4	4-1/4"	12GA	1000
OD0437S4	4-3/8"	12GA	1000
OD0450S4	4-1/2"	12GA	1000
OD0462S4	4-5/8"	12GA	1000
OD0475S4	4-3/4"	12GA	1000
OD0487S4	4-7/8"	12GA	1000

Part Number	OD Size (in)	Strap GA	Max. Rec. Load (lbs.)
OD0500S4	5"	12GA	1000
OD0512S4	5-1/8"	12GA	1000
OD0525S4	5-1/4"	12GA	1000
OD0537S4	5-3/8"	12GA	1000
OD0550S4	5-1/2"	12GA	1000
OD0562S4	5-5/8"	10GA	1000
OD0575S4	5-3/4"	10GA	1000
OD0587S4	5-7/8"	10GA	1000
OD0600S4	6"	10GA	1000
OD0612S4	6-1/8"	10GA	1000
OD0625S4	6-1/4"	10GA	1000
OD0637S4	6-3/8"	10GA	1000
OD0650S4	6-1/2"	10GA	1000
OD0662S4	6-5/8"	10GA	1000
OD0675S4	6-3/4"	10GA	1000
OD0687S4	6-7/8"	10GA	1000
OD0700S4	7"	10GA	1000
OD0712S4	7-1/8"	10GA	1000
OD0725S4	7-1/4"	10GA	1000
OD0737S4	7-3/8"	10GA	1000
OD0750S4	7-1/2"	10GA	1000
OD0762S4	7-5/8"	10GA	1000
OD0775S4	7-3/4"	10GA	1000
OD0787S4	7-7/8"	10GA	1000
OD0800S4	8"	10GA	1000
OD0812S4	8-1/8"	10GA	1000
OD0825S4	8-1/4"	10GA	1000
OD0837S4	8-3/8"	10GA	1000
OD0850S4	8-1/2"	10GA	1000
OD0862S4	8-5/8"	10GA	1000

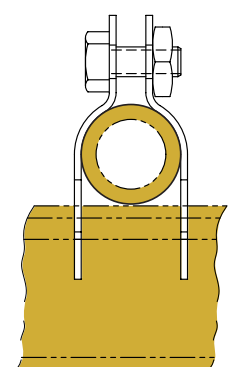
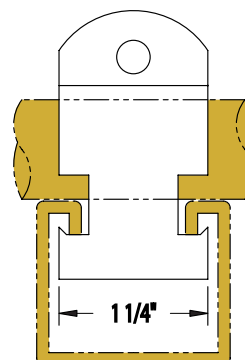

STRUT PIPE CLAMPS RIGD

304 Stainless Steel Heavy Duty Strut Clamps

- Size Range: 3/8" thru 8"
- 1-piece break apart design (1/2" thru 4" pipe size) includes captive combo head machine screw and built in nut (thread impression)



Part Number	Nominal Pipe Size	O.D.	Screw GA	Max. Rec. Load (lbs.)
RIGD0037S4	3/8"	.675"	17 GA	400
RIGD0050S4	1/2"	.840"	14 GA	400
RIGD0075S4	3/4"	1.050"	14 GA	600
RIGD0100S4	1"	1.315"	14 GA	600
RIGD0125S4	1-1/4"	1.660"	14 GA	600
RIGD0150S4	1-1/2"	1.900"	12 GA	800
RIGD0200S4	2"	2.375"	12 GA	800
RIGD0250S4	2-1/2"	2.875"	12 GA	800
RIGD0300S4	3"	3.500"	12 GA	800
RIGD0350S4	3-1/2"	4.000"	11 GA	1000
RIGD0400S4	4"	4.500"	11 GA	1000
RIGD0500S4	5"	5.563"	12 GA	1000
RIGD0600S4	6"	6.625"	10 GA	1000
RIGD0800S4	8"	8.625"	10 GA	1000

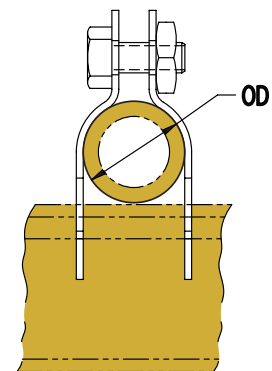
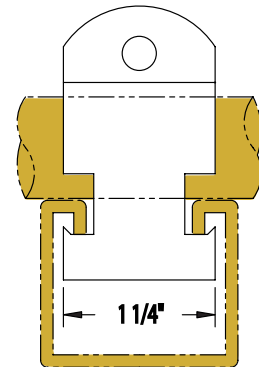





Page 228



Page 229



Page 229



Page 230

Hardware Anchors HMZ

345R

RAWL

26



Page 230



Page 231



Page 231



Page 232

30

31

SWF

35



Page 232



Page 233



Page 233



Page 234

SWFF

40

SWM

47



Page 234



Page 235



Page 235



Page 236

SWMF

HSCR

85

80





Page 236

15



Page 237

740



Page 237

4H



Page 238

ESGP



Page 238

MSP

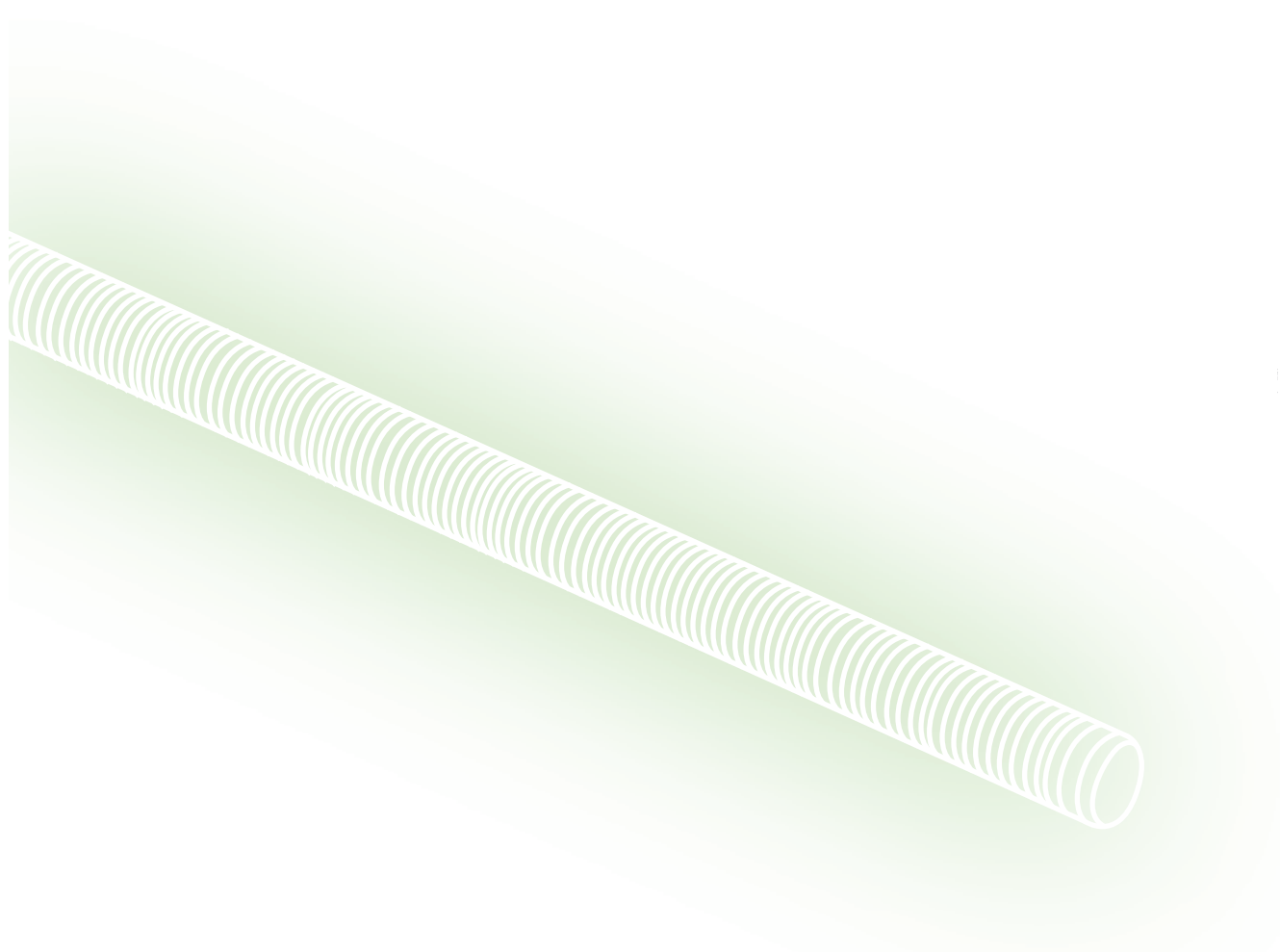

PROTECTION PLATE 304B2

Press-on Nail Plate for Wood or Metal Studs

- Size Range: 3-1/8" x 1-1/2"
- Surface Finish: Zinc phosphate
- For wood or metal studs
- Press-on installation; no tools required
- Protects plumbing and fire protection piping
- Breakable tabs permit multiple plates to be ganged together

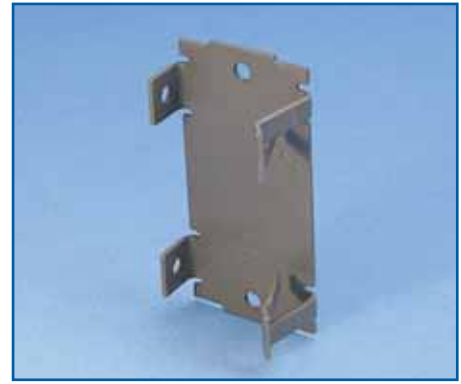

NOTE: Holes on legs and surface of plate are provided to secure with nail or screw

Part Number	Material
304B2	16 gauge steel

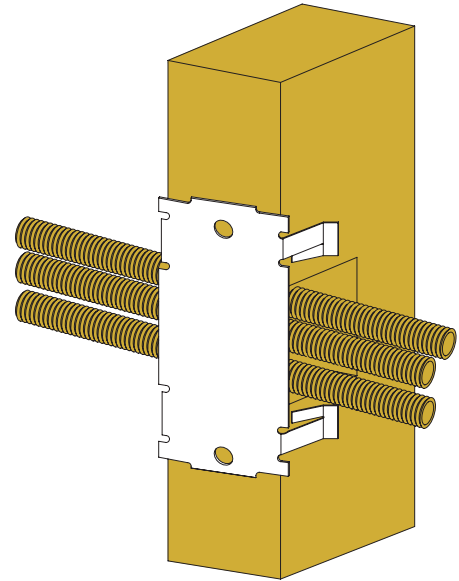
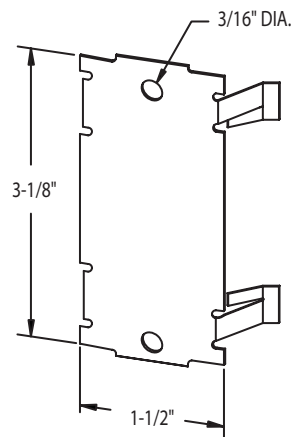

PROTECTION PLATE 005

Hammer-on Nail Plate for Wood Studs

- Surface Finish: Plain
- Protects plumbing and fire protection piping in wood studs

Part Number	Size	Material
005275150PL	2-3/4" x 1-1/2"	16 gauge steel
005325275PL	3-1/4" x 2-3/4"	16 gauge steel
005550150PL	5-1/2" x 1-1/2"	16 gauge steel

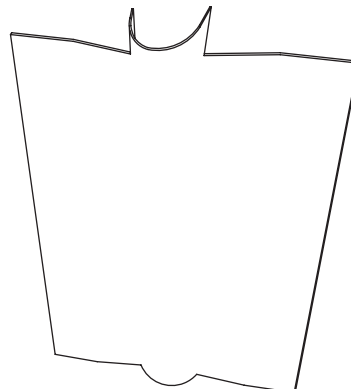
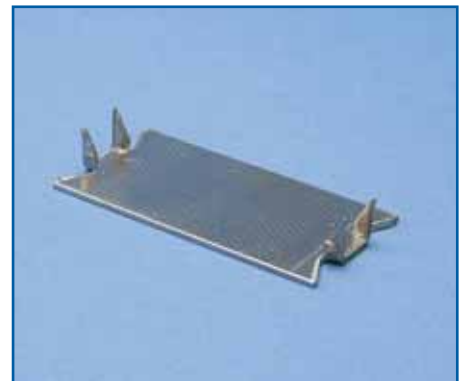

HARDWARE NUT 10

Steel Hex Nut

- Size Range: 1/4" thru 7/8"
- Surface Finish: Plain and Electro-zinc plated



Part Number	Size
Plain Finish	
0100025PL	1/4 UNC
0100037PL	3/8 UNC
0100050PL	1/2 UNC
0100062PL	5/8 UNC
0100075PL	3/4 UNC
0100087PL	7/8 UNC
Electro-zinc Plated Finish	
0100025EG	1/4 UNC
0100037EG	3/8 UNC
0100050EG	1/2 UNC
0100062EG	5/8 UNC
0100075EG	3/4 UNC
0100087EG	7/8 UNC

HARDWARE NUT 10H

Heavy Duty Steel Hex Nut

- Size Range: 1/4" thru 7/8"
- Surface Finish: Plain and Electro-zinc plated



Part Number	Size
Plain Finish	
010H0025PL	1/4 UNC
010H0037PL	3/8 UNC
010H0050PL	1/2 UNC
010H0062PL	5/8 UNC
010H0075PL	3/4 UNC
010H0087PL	7/8 UNC
Electro-zinc Plated Finish	
010H0025EG	1/4 UNC
010H0037EG	3/8 UNC
010H0050EG	1/2 UNC
010H0062EG	5/8 UNC
010H0075EG	3/4 UNC
010H0087EG	7/8 UNC



HARDWARE WASHER 11

Round Steel Flat Washer

- Size Range: 1/4" thru 7/8"
- Surface Finish: Plain and Electro-zinc plated

Part Number	Size	ID	OD
Plain Finish			
0110025PL	1/4"	5/16"	3/4"
0110037PL	3/8"	7/16"	1"
0110050PL	1/2"	9/16"	1-3/8"
0110062PL	5/8"	11/16"	1-3/4"
0110075PL	3/4"	13/16"	2"
0110087PL	7/8"	15/16"	2-1/4"
Electro-zinc Plated Finish			
0110025EG	1/4"	5/16"	3/4"
0110037EG	3/8"	7/16"	1"
0110050EG	1/2"	9/16"	1-3/8"
0110062EG	5/8"	11/16"	1-3/4"
0110075EG	3/4"	13/16"	2"
0110087EG	7/8"	15/16"	2-1/4"

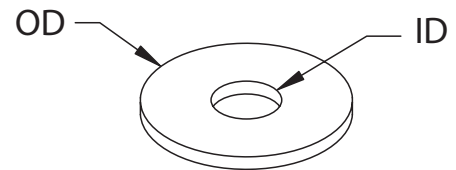

HARDWARE WASHER 12

Steel Fender Washer

- Size Range: 1/4", 3/8" and 1/2"
- Surface Finish: Electro-zinc Plated

Part Number	Size	ID	OD
0120025EG	1/4"	5/16"	1-1/16"
0120037EG	3/8"	7/16"	1-1/2"
0120050EG	1/2"	9/16"	2"

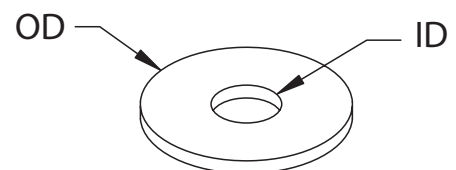

HARDWARE THREADED ROD 50

All Thread Rod

- Size Range: 1/4" thru 7/8"
- Surface Finish: Plain and Electro-zinc Plated
- Attaches hangers to structural attachments without threading the rod, UNC Thread Form

NOTE: Low carbon: tensile: 58,000 psi; yield: 36,000 psi, available in Stainless Steel for 3/8" and 1/2" rod size



Part Number	RS	L	Max. Rec. Load (lbs)*
Plain Finish			
0502506PL	1/4"	6'	240
0502510PL	1/4"	10'	240
0502512PL	1/4"	12'	240
0503706PL	3/8"	6'	610
0503710PL	3/8"	10'	610
0503712PL	3/8"	12'	610
0505006PL	1/2"	6'	1130
0505010PL	1/2"	10'	1130
0505012PL	1/2"	12'	1130
0506206PL	5/8"	6'	1810
0506210PL	5/8"	10'	1810
0506212PL	5/8"	12'	1810
0507506PL	3/4"	6'	2710
0507510PL	3/4"	10'	2710
0507512PL	3/4"	12'	2710
0508706PL	7/8"	6'	3770
0508710PL	7/8"	10'	3770
0508712PL	7/8"	12'	3770
Electro-zinc Plated Finish			
0502506EG	1/4"	6'	240
0502510EG	1/4"	10'	240
0502512EG	1/4"	12'	240
0503706EG	3/8"	6'	610
0503710EG	3/8"	10'	610
0503712EG	3/8"	12'	610
0505006EG	1/2"	6'	1130
0505010EG	1/2"	10'	1130
0505012EG	1/2"	12'	1130
0506206EG	5/8"	6'	1810
0506210EG	5/8"	10'	1810
0506212EG	5/8"	12'	1810
0507506EG	3/4"	6'	2710
0507510EG	3/4"	10'	2710
0507512EG	3/4"	12'	2710
0508706EG	7/8"	6'	3770
0508710EG	7/8"	10'	3770
0508712EG	7/8"	12'	3770

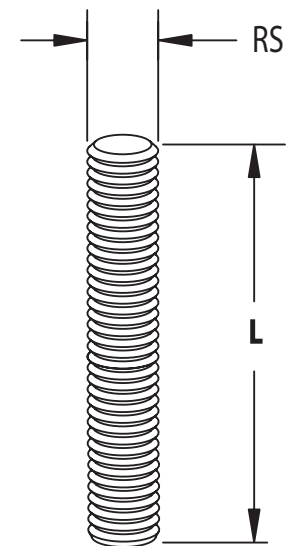

*Load based on Max. 650° F

HARDWARE THREADED STUD 51

Threaded Studs

- Size Range: 3/8" and 1/2" rod sizes
- Surface Finish: Plain
- Attaches hangers to structural attachments without threading or cutting the rod, UNC Thread Form

NOTE: Low carbon: tensile: 58,000 psi; yield: 36,000 psi



Part Number	RS	L	Max. Rec. Load (lbs)*
0513702PL	3/8"	2"	610
0513703PL	3/8"	3"	610
0513704PL	3/8"	4"	610
0513705PL	3/8"	5"	610
0513706PL	3/8"	6"	610
0515004PL	1/2"	4"	1130
0515005PL	1/2"	5"	1130
0515006PL	1/2"	6"	1130
0515010PL	1/2"	10"	1130
0515012PL	1/2"	12"	1130

*Load based on Max. 650° F

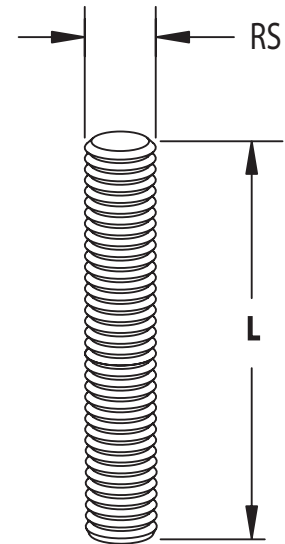

HARDWARE ROD COUPLING 25

Steel Rod Coupling

- Size Range: 1/4" thru 7/8" rod sizes
- Surface Finish: Electro-zinc Plated
- Intermediate accessory designed to join two lengths of similar UNC threaded rod



Part Number	RS	L	Max. Rec. Load (lbs)
0250025EG	1/4"	7/8"	240
0250037EG	3/8"	1-3/4"	610
0250050EG	1/2"	1-3/4"	1130
0250062EG	5/8"	2-1/8"	1810
0250075EG	3/4"	2-1/4"	2710
0250087EG	7/8"	2-1/2"	3770

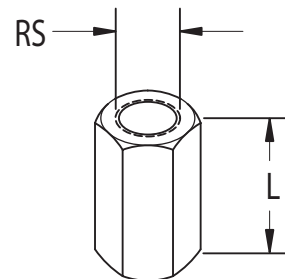

HARDWARE ROD COUPLING 25S

Short Steel Rod Coupling

- Size Range: 3/8" and 1/2" rod sizes
- Surface Finish: Electro-zinc Plated
- Intermediate accessory designed to join two lengths of similar UNC threaded rod



Part Number	RS	L	Max. Rec. Load (lbs)
025S0037EG	3/8"	1-1/8"	N/A
025S0050EG	1/2"	1-1/4"	N/A

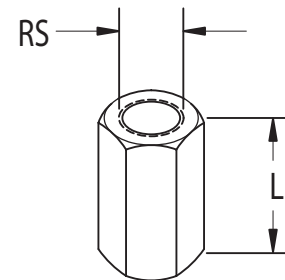

HARDWARE ROD COUPLING 25R

Reducing Steel Rod Coupling

- Size Range: 3/8", 1/2" and 5/8" rod sizes
- Surface Finish: Electro-zinc plated
- Intermediate accessory designed to join dissimilar sizes of UNC rod



NOTE: Never use smaller rod sizes than the minimum rod sizes noted in MSS-SP-69

Part Number	RS	RS1	L	Max. Pipe Size	Max. Rec. Load (lbs)
025R3725EG	3/8"	1/4"	1"	3/8"	240
025R5037EG	1/2"	3/8"	1-1/4"	2"	610
025R6250EG	5/8"	1/2"	1-1/4"	3-1/2"	1130

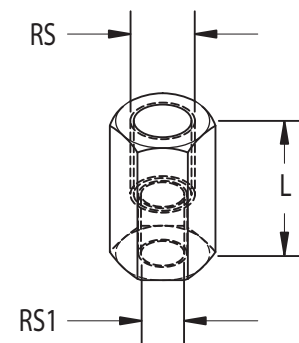

HARDWARE COACH SCREW 41

Coach Screw Rod

- Size Range: 3/8" and 1/2" rod sizes
- Surface Finish: Plain
- Light duty hanger rod for wood structures



Part Number	RS	L	L1	L2	Max. Pipe Size	Max. Rec. Load (lbs)
0413704PL	3/8"	4"	1-1/8"	2"	2"	390
0413706PL	3/8"	6"	1-1/2"	2-3/4"	2"	390
0413708PL	3/8"	8"	1-1/2"	2-1/2"	2"	390
0413710PL	3/8"	10"	2"	2-1/2"	2"	390
0413712PL	3/8"	12"	1-5/8"	2-1/2"	2"	390
0415004PL	1/2"	4"	2"	2"	3"	640
0415006PL	1/2"	6"	2"	2"	3"	640
0415008PL	1/2"	8"	2-1/4"	2-1/2"	3"	640
0415010PL	1/2"	10"	2-3/8"	2-1/4"	3"	640
0415012PL	1/2"	12"	2-3/8"	2-1/4"	3"	640

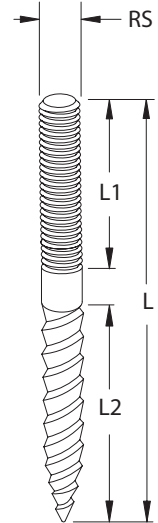

HARDWARE LAG SCREW 42

Lag Screw

- Size Range: 1/4", 3/8" and 1/2"
- Surface Finish: Electro-zinc Plated
- Fastener for mounting various structural attachments onto wood



Part Number	BS	L
0422515EG	1/4"	1-1/2"
0422520EG	1/4"	2"
0423710EG	3/8"	1"
0423715EG	3/8"	1-1/2"
0423720EG	3/8"	2"
0423725EG	3/8"	2-1/2"
0423730EG	3/8"	3"
0423740EG	3/8"	4"
0425015EG	1/2"	1-1/2"
0425020EG	1/2"	2"
0425025EG	1/2"	2-1/2"
0425030EG	1/2"	3"
0425040EG	1/2"	4"

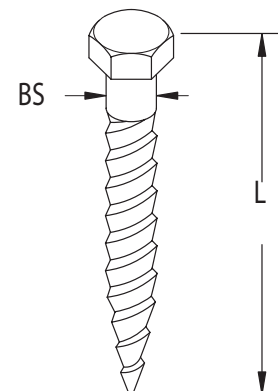

HARDWARE DRIVE SCREW 43

Wood Drive Screw

- Size Range: #14 and #16
- Surface Finish: Electro-zinc Plated
- Light duty fastener for mounting various structural attachments onto wood

NOTE: Install only in shear, never use under pull-out configuration



Part Number	Size
0431402EG	#14
0431602EG	#16

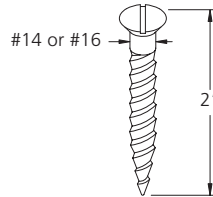

HARDWARE NUT 100A

Swivel Loop Insert Nut

- Size Range: 3/8" and 1/2" rod sizes
- Surface Finish: Electro-zinc Plated
- Insert nut used to attach loop hanger to threaded rod

NOTE: Used with Model numbers 100, 101, 102 and 102A loop hangers



Part Number	Size
100A0037EGP100	3/8"
100A0050EGP100	1/2"

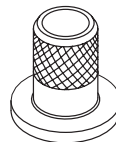

HARDWARE TOGGLE NUT 145

Spring Toggle Wing Nut

- Size Range: 3/8" and 1/2" rod sizes
- Surface Finish: Electro-zinc Plated
- Used with threaded rod in hollow wall applications



Part Number	Rod Size	Drill Hole Size	A
1450037EG	3/8"	1"	3"
1450050EG	1/2"	1-1/4"	4-7/16"

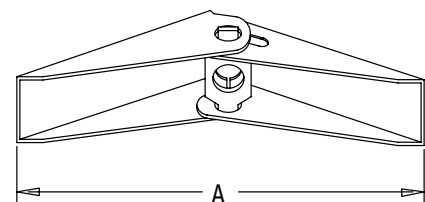

HARDWARE ANCHORS HMZ





HangerMate® Anchors

- Used for supporting/anchoring threaded rod in wood, steel or concrete structural members

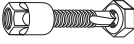
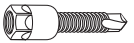
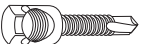
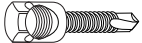
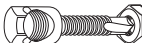
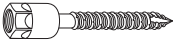
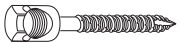
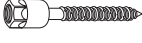
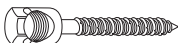
NOTE: For use on horizontal and vertical surfaces

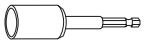

	Part Number	RS	Description
Steel Applications – Vertical Mount (End-drilled Head)			
	HMZG471	3/8-16	3/8" rod anchor for steel and purlin
	HMZG550	3/8-16	Self drilling anchor for steel 16 ga. - 1/4"
Steel Applications – Horizontal Mount (Cross-drilled Head)			
	HMZH455	3/8-16	3/8" rod anchor for sidewall (.125" max)
	HMZH475	3/8-16	3/8" rod anchor for steel (.25" max)
	HMZH476	3/8-16	3/8" rod anchor sidewall, steel and purlin
Wood Applications – Vertical Mount (End-drilled Head)			
	HMZG660	3/8-16	Self drilling 3/8" rod anchor for wood
Wood Applications – Horizontal Mount (Cross-drilled Head)			
	HMZH665	3/8-16	3/8" rod anchor for sidewall/wood
Concrete Applications – Vertical Mount (End-drilled Head)			
	HMZG730	3/8-16	3/8" rod anchor for concrete
Concrete Applications – Horizontal Mount (Cross-drilled Head)			
	HMZG735	3/8-16	5/16" x 2-1/4" HangerMate Anchor

	Part Number	Description
Installation Tools		
	HMZE200	Recessed drive socket for metal and wood side-mount applications
	HMZE215	Vertical recessed drive socket for metal and wood vertical-mount applications
	HMZE220	Concrete recessed drive socket sleeve
	HMZE230	Carbide countersink tool – use with HMZG730 for concrete/masonry applications
	HMZE380	SDS Hex Shank Drill Bit



HARDWARE ANCHORS 345R

Concrete Drop-in Anchor

- Size Range: 3/8", 1/2" and 5/8" rod sizes
- Surface Finish: Electro-zinc Plated
- Special anchor design offers fast and easy installation and provides maximum holding power
- May be installed flush with masonry surface



NOTE: Furnished with a pre-assembled internal expander plug.

Part Number	RS	A	MRI	Concrete Drill Size	Tension Load (lbs)	Shear Load (lbs)	Material
345R0037EG	3/8"	1-9/16"	5/8"	1/2"	6400	4220	Steel
345R0050EG	1/2"	2"	13/16"	5/8"	9000	6640	Steel
345R0062EG	5/8"	2-1/2"	1-3/16"	7/8"	15218	10380	Steel

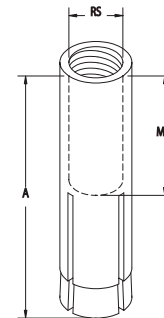

HARDWARE ANCHOR RAWL

RAWL Concrete Pipe Spike

- Size Range: 3/8" rod size
- Use in concrete with threaded rod
- Vibration-resistant



Part Number	Size	Drill Diameter	Min. Depth
RAWL3758	3/8"	1/4"	1-1/4"

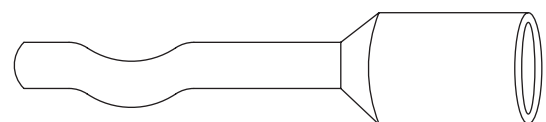

HARDWARE EXTENSION 26

Malleable Iron Extension Piece

- Size Range: 3/8" thru 7/8" rod sizes
- Surface Finish: Black
- Intermediate accessory that may attach to the side of a structural member or to a beam clamp
- Extension may be used in conjunction with Model #360



Part Number	RS	MRI	A	B	C	Max. Rec. Load (lbs)
0260037PL	3/8"	5/8"	2-1/16"	5/8"	1/2"	610
0260050PL	1/2"	11/16"	2-5/16"	11/16"	1/2"	1130
0260062PL	5/8"	7/8"	2-7/16"	5/8"	1/2"	1550
0260075PL	3/4"	1"	2-7/8"	3/4"	1/2"	2100
0260087PL	7/8"	1-1/16"	3"	13/16"	9/16"	2350

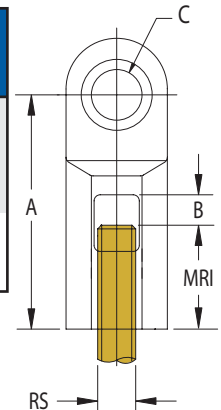

HARDWARE TURNBUCKLE 30

Forged Steel Turnbuckle

- Size Range: 3/8" thru 7/8" rod sizes
- Surface Finish: Plain
- Intermediate accessory that provides up to 5-1/2" of vertical adjustment for heavy loads
- Conforms with Federal Specification WW-H-171 (Type 13), Manufacturers Standardization Society MSS-SP-58 (Type 13); install in accordance with ANSI/MSS-SP-69



NOTE: Ends are threaded in opposite directions

Part Number	RS	MRI	A	B	Max. Rec. Load (lbs)
0300037PL	3/8"	11/16"	5-3/4"	7-1/8"	1200
0300050PL	1/2"	7/8"	5-3/4"	7-1/2"	2200
0300062PL	5/8"	1-1/8"	5-5/8"	7-7/8"	3500
0300075PL	3/4"	1-7/16"	5-3/8"	8-1/4"	5200
0300087PL	7/8"	1-9/16"	5-1/2"	8-5/8"	7200

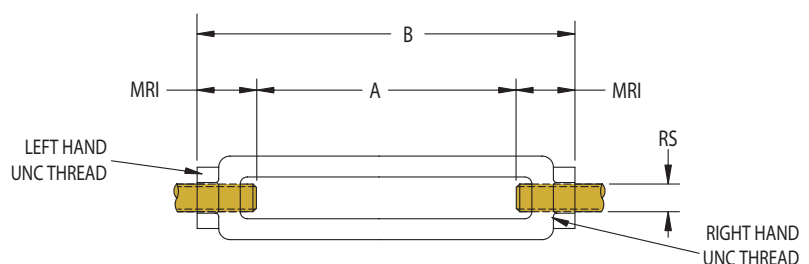

HARDWARE CLEVIS 31

Forged Steel Rod Clevis

- Size Range: 3/8" thru 2" rod sizes
- Surface Finish: Plain
- Intermediate accessory designed to attach to vertical plates that have been welded to structure or pipe
- Conforms with Federal Specification WW-H-171 (Type 14), Manufacturers Standardization Society MSS-SP-58 (Type 14); install in accordance with ANSI/MSS-SP-69



Part Number	RS	Body No.	MRI	A	B	C	Max. Rec. Load (lbs)
0310037PL	3/8"	2	15/16"	3-5/8"	1/2"	3/8"	610
0310050PL	1/2"	2	15/16"	3-5/8"	5/8"	1/2"	1130
0310062PL	5/8"	2	1-1/16"	3-5/8"	3/4"	5/8"	1810
0310075PL	3/4"	2-1/2	1-3/16"	4"	7/8"	3/4"	2710
0310087PL	7/8"	2-1/2	1-3/16"	4"	1"	7/8"	3770
0310100PL	1"	3	1-7/16"	4-15/16"	1-1/8"	1"	4960
0310125PL	1-1/4"	3	1-1/2"	4-15/16"	1-1/2"	1-1/4"	8000
0310150PL	1-1/2"	3-1/2	2-1/16"	6"	1-3/4"	1-1/2"	11630
0310175PL	1-3/4"	4	2-9/16"	6"	2"	1-3/4"	15700
0310200PL	2"	5	2-11/16"	7"	2-1/4"	2"	20700

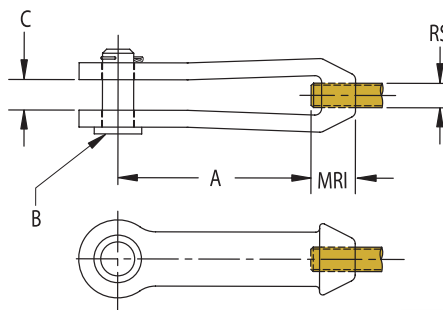

HARDWARE SWIVEL SWF

Swivel Female

- Size Range: 3/8" and 1/2" rod sizes
- Surface Finish: Electro-zinc plated
- Threaded rod attachment with the capability to swivel



Part Number	RS	A	B	Max. Rec. Load (lbs)
SWF0037EG	3/8"	1-3/4"	1/2"	1000
SWF0050EG	1/2"	2"	3/4"	1800

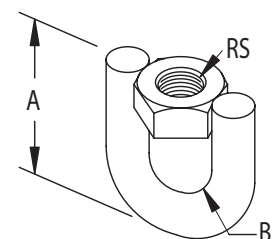

HARDWARE EYE NUT 35

Forged Steel Eye Nut

- Size Range: 3/8" thru 7/8" rod sizes
- Surface Finish: Plain
- Intermediate accessory for high temperature piping used in conjunction with Models: #320, #360, #361, #450, #451, #452 and #453
- Conforms with Federal Specification WW-H-171 (Type 17), Manufacturers Standardization Society MSS-SP-58 (Type 17); install in accordance with ANSI/MSS-SP-69



Part Number	RS	A	B	C	MRI	Max. Rec. Load (lbs)
0350037PL	3/8"	1-3/4"	3-1/8"	1"	5/8"	1250
0350050PL	1/2"	1-11/16"	3-1/8"	1-1/2"	3/4"	2250
0350062PL	5/8"	1-11/16"	3-1/8"	1-1/2"	3/4"	3600
0350075PL	3/4"	1-11/16"	3-1/8"	1-1/2"	3/4"	5200
0350087PL	7/8"	2-1/4"	4-3/8"	2"	1-1/8"	7200

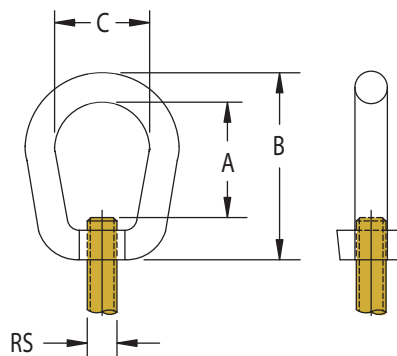

HARDWARE SWIVEL SWFF

Swivel Female-Female

- Size Range: 3/8" and 1/2" rod sizes
- Surface Finish: Electro-zinc Plated
- Threaded rod attachment with the capability to swivel



Part Number	RS	A	Max. Rec. Load (lbs)
SWFF0037EG	3/8"	2-3/4"	1000
SWFF0050EG	1/2"	3"	1800

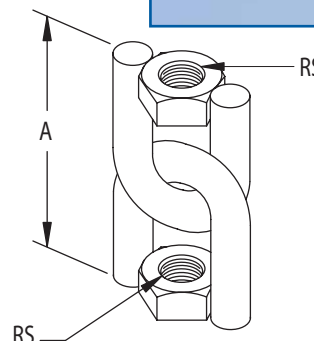

HARDWARE EYE ROD 40

Steel Eye Rod

- Size Range: 3/8" rod size
- Surface Finish: Plain
- Structural attachment with Model #42 lag screw or as a hanger rod from other structural attachments
- Capable of being used in connection with Models: #360, #361, etc.



Part Number	RS	A	B	C	Max. Rec. Load (lbs)
0403704PL	3/8"	4"	2-1/2"	1/2"	240
0403706PL	3/8"	6"	2-1/2"	1/2"	240
0403708PL	3/8"	8"	2-1/2"	1/2"	240

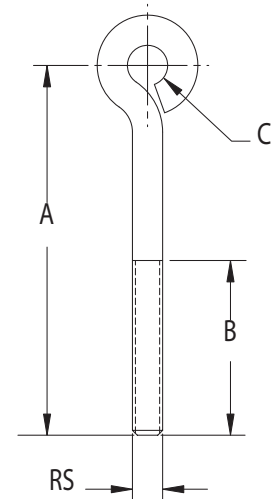

HARDWARE SWIVEL SWM

Swivel Male

- Size Range: 3/8" and 1/2" rod sizes
- Surface Finish: Electro-zinc plated
- Threaded rod attachment with the capability to swivel



Part Number	RS	A	B	Max. Rec. Load (lbs)
SWM0037EG	3/8"	1-3/4"	1/2"	1000
SWM0050EG	1/2"	2"	3/4"	1800

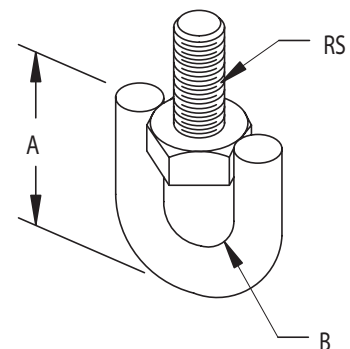

HARDWARE EYE NUT 47

Malleable Iron Eye Nut

- Size Range: 1/4" thru 7/8" rod sizes
- Surface Finish: Black
- Intermediate attachment for various types of pipe supports and structural attachments
- Conforms with Federal Specification WW-H-171 (Type 16), Manufacturers Standardization Society MSS-SP-58 (Type 16); install in accordance with ANSI/MSS-SP-69



Part Number	RS	A	B	C	MRI	Max. Rec. Load (lbs)
0470025PL	1/4"	5/8"	1-3/4"	5/16"	1/2"	230
0470037PL	3/8"	3/4"	1-5/8"	3/8"	5/8"	610
0470050PL	1/2"	3/4"	1-7/8"	3/8"	3/4"	1130
0470062PL	5/8"	15/16"	2-1/8"	5/8"	3/4"	1400
0470075PL	3/4"	1-3/16"	2-1/2"	5/8"	7/8"	1900
0470087PL	7/8"	1-1/4"	2-7/8"	5/8"	1-1/16"	2200

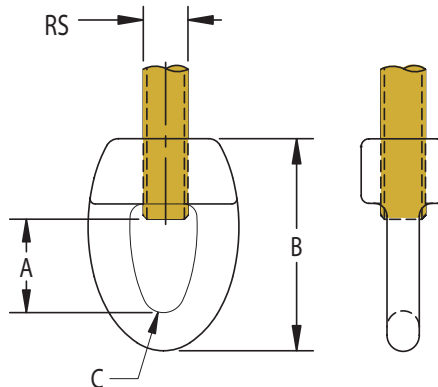

HARDWARE SWIVEL SWMF

Swivel Male-Female

- Size Range: 3/8" and 1/2" rod sizes
- Surface Finish: Electro-zinc Plated
- Threaded rod attachment with the capability to swivel



Part Number	RS	A	Max. Rec. Load (lbs)
SWMF0037EG	3/8"	2-3/4"	1000
SWMF0050EG	1/2"	3"	1800

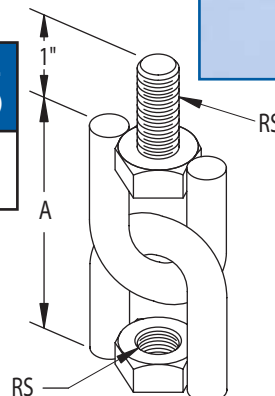

HARDWARE HEX BOLT HSCR

Steel Hex Cap Bolts

- Size Range: 3/8" and 1/2" sizes
- Surface Finish: Plain and Electro-zinc Plated

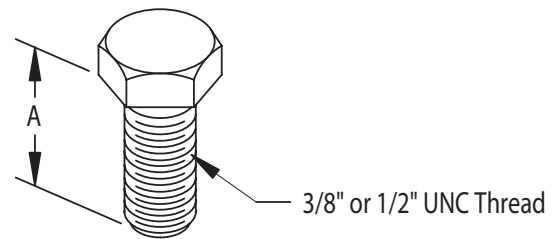

Part Number	Thread Size	A
Plain Finish		
HSCR3710PL	3/8" - 16	1"
HSCR3712PL	3/8" - 16	1-1/4"
HSCR3715PL	3/8" - 16	1-1/2"
HSCR3720PL	3/8" - 16	2"
Electro-zinc Plated Finish		
HSCR3707EG	3/8" - 16	3/4"
HSCR3710EG	3/8" - 16	1"
HSCR3712EG	3/8" - 16	1-1/4"
HSCR3715EG	3/8" - 16	1-1/2"
HSCR3720EG	3/8" - 16	2"
HSCR5007EG	1/2" - 13	3/4"
HSCR5010EG	1/2" - 13	1"
HSCR5012EG	1/2" - 13	1-1/4"
HSCR5015EG	1/2" - 13	1-1/2"
HSCR5020EG	1/2" - 13	2"

HARDWARE J-BOLT 85

Steel J-bolt

- Size Range: 3/8" and 1/2" rod sizes
- Surface Finish: Plain
- Allows bolt to be hooked or hung from beam flange or purlin

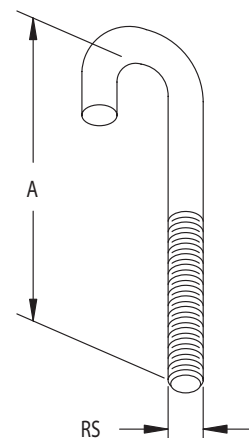

Part Number	RS	A	Max. Rec. Load (lbs)
085370400PL	3/8"	4"	240
085370500PL	3/8"	5"	240
085370600PL	3/8"	6"	240
085370700PL	3/8"	7"	240
085370800PL	3/8"	8"	240
085370900PL	3/8"	9"	240
085371000PL	3/8"	10"	240
085500600PL	1/2"	6"	440
085500700PL	1/2"	7"	440
085500800PL	1/2"	8"	440
085500900PL	1/2"	9"	440
085501000PL	1/2"	10"	440

HARDWARE TIE BOLT 80

Steel Tie Bolt

- Size Range: 3/4" x 4-1/2"
- Surface Finish: Black
- Used to secure connection of installation of private fire service mains

NOTE: Conforms to NFPA® pamphlet #2, 4" – 12" pipe size



Part Number	Material
080750450L	3/4" x 4-1/2"

HARDWARE ROD BUTTON 15

Threaded Rod Ceiling Buttons

- Size Range: 3/8" and 1/2" rod sizes
- Surface Finish: White or Chrome
- Recommended for giving a finished appearance where rod enters ceiling



Part Number	Size	Material
0150037W	3/8"	White
0150037PC	3/8"	Chrome
0150050W	1/2"	White



HARDWARE PIPE SLEEVE POSITIONER 740

Hammer-on Pipe Sleeve Positioner Clips

- Size Range: Less than 5/16" wall thickness
- Surface Finish: CADDY® COAT
- Used to position pipe sleeves and prevent movement during concrete pours

NOTE: No load rating, for positioning only

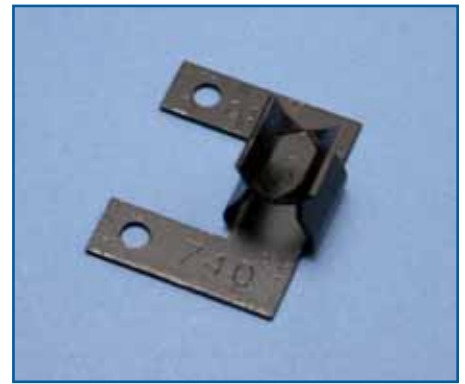

Part Number	Sleeve Diameter	Wall Thickness
740	All	5/16" and under
740	2" – 6"	Sch. 40 pipe

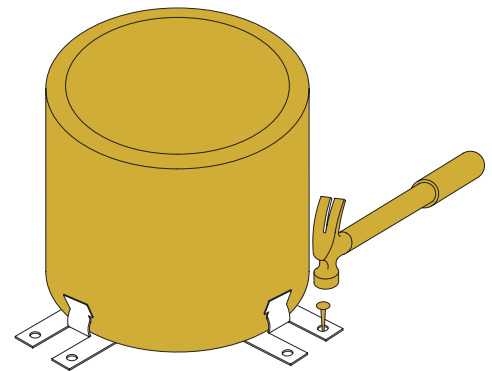

HARDWARE SLEEVE POSITIONER 4H

Hammer-on Pipe Sleeve Positioner Clips

- Size Range: 6" thru 14" Schedule 80 pipe
- Surface Finish: CADDY® COAT
- Used to position pipe sleeves and prevent movement during concrete pours

NOTE: No load rating, for positioning only



Part Number	Sleeve Diameter	Wall Thickness
4H24	1" – 4" 1/2" – 2"	Schedule 40 Schedule 80
4H58	5" – 6" 8" – 10"	Schedule 80 Schedule 40
4H912	9" – 14"	Schedule 80

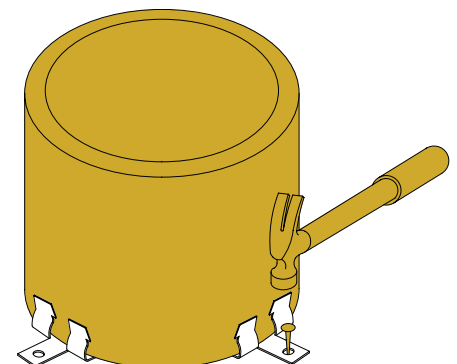

HARDWARE GROMMET ESGP

Easy Snap/Anti Rattle Pipe Grommet

- Size Range: 1/2" thru 1" copper tubing
- Yellow plastic pipe grommet provides 360° protection of plumbing and fire sprinkler plumbing in metal studs

NOTE: Snap one grommet into standard 1-11/32" field punched hole, or snap two together into any shape factory punched hole; anti-rattle tabs in ESGP allow grommet to accommodate copper tubing from 1/2" to 1"



Part Number	Size
ESGP	1/2" – 1" CT

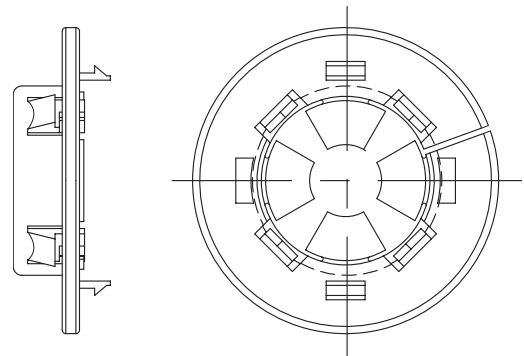

HARDWARE TOOLS MSP

Metal Stud Punch

- Used in the field for punching standard sized 1-11/32" holes in metal studs
- Cushioned handles mean less operator fatigue and more comfortable handling
- Tool design with offset handles allows punch to work in confined locations and near perpendicular walls
- Lightweight punch makes accurate location of holes easier
- Hardened steel components keep tool sharp longer – less replacement
- Plastic grommets (ESGP) snap easily into 1-11/32" hole



Part Number
MSP20





Page 240

SAA



Page 240

SAD

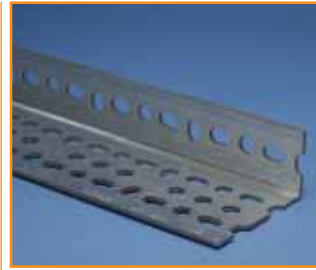

Page 241

SAE



SLOTTED ANGLE FRAMING SAA

- Size Range: 1-5/8" x 1-5/8", 14 gauge
- Surface Finish: Electro-zinc plated

Part Number	L
SAA1400EG	10'

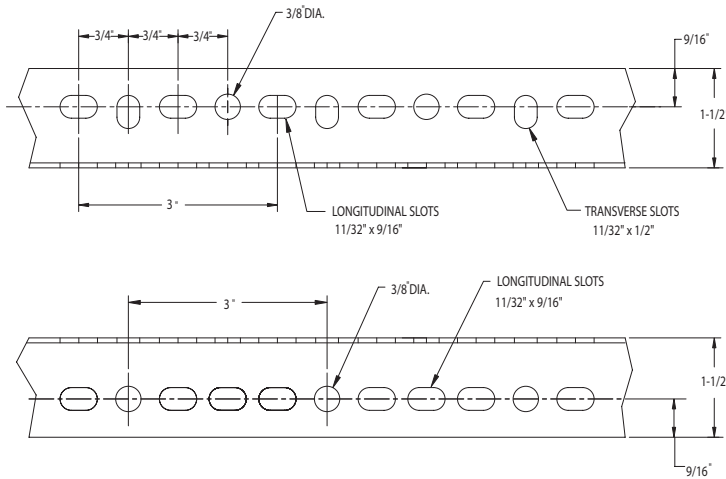

FRAMING SAD

- Size Range: 1-5/8" x 2-7/16", 14 gauge
- Surface Finish: Electro-zinc plated

Part Number	L
SAD1400EG	10'

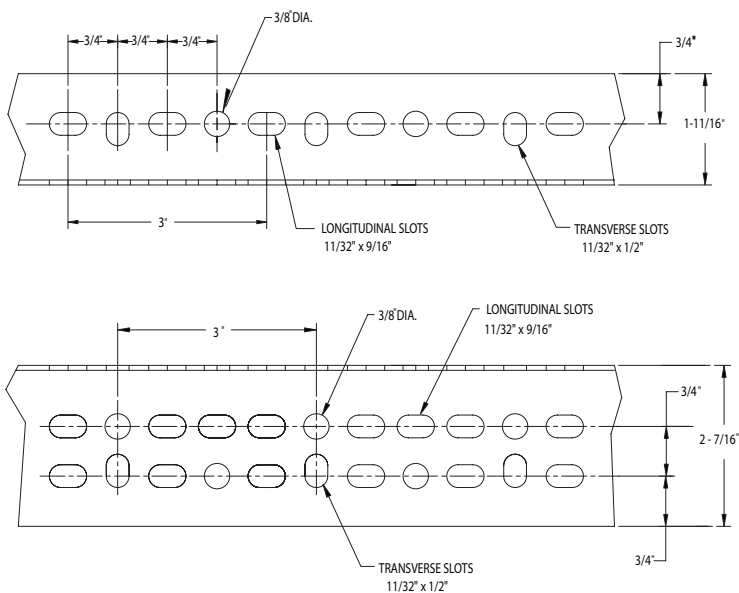

SLOTTED ANGLE FRAMING SAE

- Size Range: 1-5/8" x 3-1/8", 12 gauge
- Surface Finish: Electro-zinc plated

Part Number	L
SAE1200EG	10'

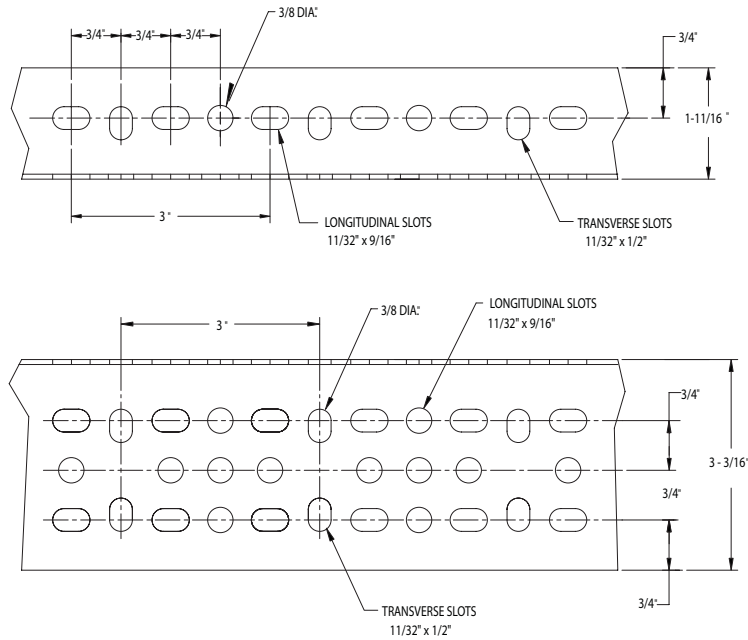





Page 244

TP220



Page 245

TP225



Page 245

TP225A



Page 246

TP230



Page 247

TP235



Page 247

TP240



Page 248

TP280



SWAY BRACING TP220

Quick Clamp Sway Brace Pipe Attachment

- Size Range: 1-1/4" thru 8" braced pipe
- Surface Finish: Black
- Used for laterally bracing pipe against sway disturbances

NOTE: Also available in EG finish



Part Number	A (Braced Pipe Size)	B (Bracing Pipe Size)	C
TP2201000125PL	1-1/4"	1"	4-13/16"
TP2201000150PL	1-1/2"	1"	5-1/8"
TP2201000200PL	2"	1"	5-5/16"
TP2201000250PL	2-1/2"	1"	6-1/2"
TP2201000300PL	3"	1"	7-1/4"
TP2201000400PL	4"	1"	8-1/8"
TP2201000500PL	5"	1"	8-5/8"
TP2201000600PL	6"	1"	10"
TP2201000800PL	8"	1"	11-3/4"
TP2201250125PL	1-1/4"	1-1/4"	5-1/4"
TP2201250150PL	1-1/2"	1-1/4"	5-1/2"
TP2201250200PL	2"	1-1/4"	6"
TP2201250250PL	2-1/2"	1-1/4"	6-1/2"
TP2201250300PL	3"	1-1/4"	7-1/4"
TP2201250400PL	4"	1-1/4"	8-5/16"
TP2201250500PL	5"	1-1/4"	9-1/4"
TP2201250600PL	6"	1-1/4"	10-1/2"
TP2201250800PL	8"	1-1/4"	12"

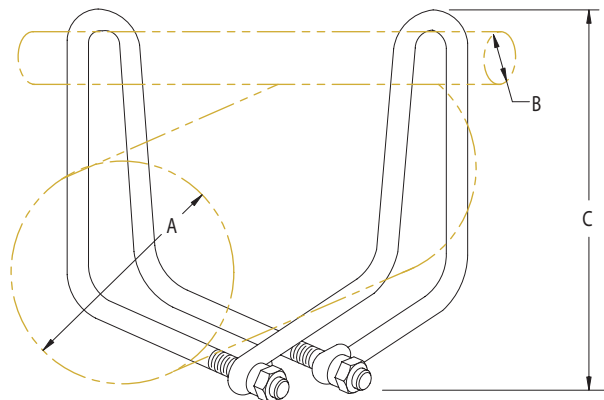

SWAY BRACING TP225

Quick End Threadless Brace Fitting

- Size Range: 1" and 1-1/4" bracing pipe
- Surface Finish: Black
- Used to ease the installation of transverse and/or longitudinal sway bracing



NOTE: Also available in EG finish

Part Number	Fig. No.	A (Bracing Pipe Size)	B	C	D
TP225G100PL*	1	1"	1-3/8"	1-1/4"	1-1/4"
TP225G125PL*	1	1-1/4"	1-5/8"	1-1/4"	1-1/4"
TP225100PL	2	1"	1-3/8"	1-3/8"	1-1/8"
TP225125PL	2	1-1/4"	1-5/8"	1-3/8"	1-1/8"

*Heavy Duty Assembly

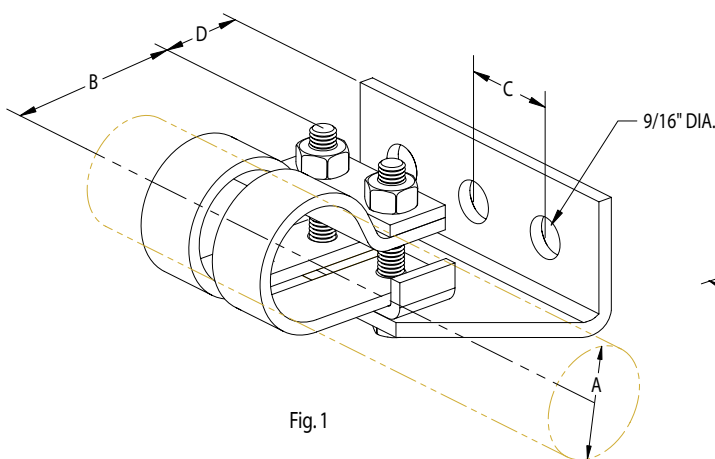

Fig. 1

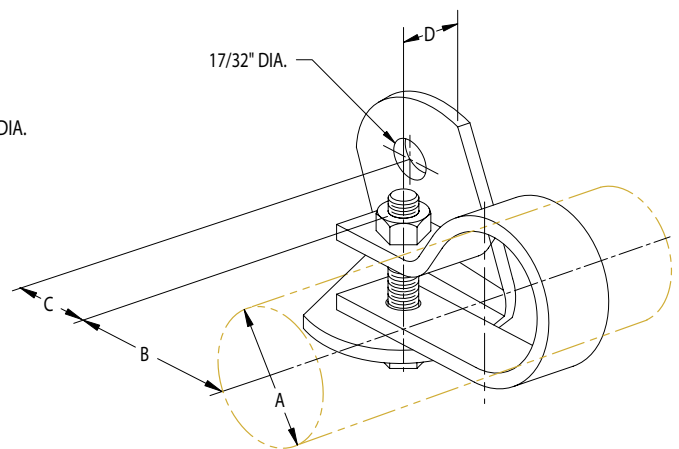

Fig. 2

SWAY BRACING TP225A

Quick Loader Adapter Plate

- Surface Finish: Black
- Allows TP225 to be attached with two or three attachment bolts



NOTE: Also available in EG finish

Part Number
TP225A000PL

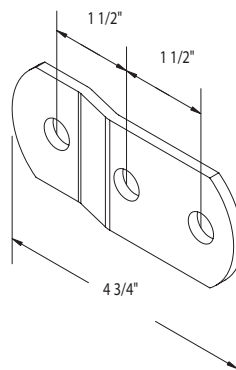

SWAY BRACING TP230

Quick In-line Longitudinal Sway Brace Clamp

- Size Range: 1" thru 8" braced pipe
- Surface Finish: Black or Electro-zinc plated
- Used for longitudinally bracing piping against sway

NOTE: Also available in EG finish



Part Number	Fig. No.	A (Braced Pipe Size)	B (Bracing Pipe Size)	C	D
TP2301000100PL	1	1"	1"	3/16"	1"
TP2301000125PL	1	1-1/4"	1"	3/16"	1"
TP2301000150PL	1	1-1/2"	1"	3/16"	1"
TP2301000200PL	1	2"	1"	3/16"	1"
TP2301000250PL	1	2-1/2"	1"	3/16"	1"
TP2301000300PL	1	3"	1"	3/16"	1"
TP2301000400PL	1	4"	1"	3/16"	1"
TP2301000500PL	1	5"	1"	3/16"	2"
TP2301000600PL	1	6"	1"	3/16"	2"
TP2301000800PL	1	8"	1"	1/4"	2"
TP2301250125PL	1	1-1/4"	1-1/4"	3/16"	1"
TP2301250150PL	1	1-1/2"	1-1/4"	3/16"	1"
TP2301250200PL	1	2"	1-1/4"	3/16"	1"
TP2301250250PL	1	2-1/2"	1-1/4"	3/16"	1"
TP2301250300PL	1	3"	1-1/4"	3/16"	1"
TP2301250400PL	1	4"	1-1/4"	3/16"	1"
TP2301250500PL	1	5"	1-1/4"	3/16"	2"
TP2301250600PL	1	6"	1-1/4"	3/16"	2"
TP2301250800PL	1	8"	1-1/4"	1/4"	2"
TP230G1000600PL*	2	6"	1"	3/16"	2"
TP230G1000800PL*	2	8"	1"	1/4"	2"
TP230G1250600PL*	2	6"	1-1/4"	3/16"	2"
TP230G1250800PL*	2	8"	1-1/4"	1/4"	2"

*Heavy Duty Assembly

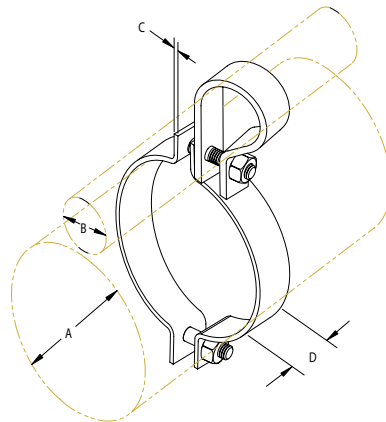

Fig.1

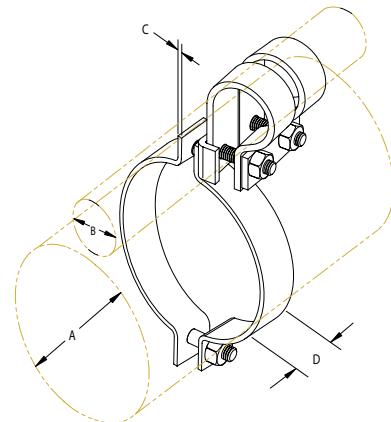

Fig.2



SWAY BRACING TP235

Quick Tab Longitudinal Sway Brace Fitting

- Size Range: 1" and 1-1/4" bracing pipe
- Surface Finish: Black
- Used for longitudinally bracing piping against sway when welding is an option



Part Number	A (Bracing Pipe Size)	B	C
TP235100PL	1"	3/16"	1"
TP235125PL	1-1/4"	3/16"	1"

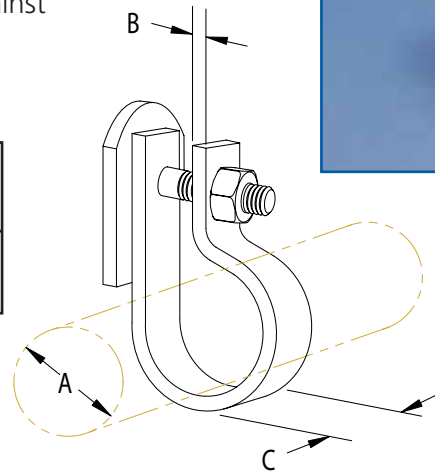

SWAY BRACING TP240

Quick 4-way Longitudinal Sway Brace Clamp

- Size Range: 1" and 1-1/4" bracing pipe
- Surface Finish: Black, Electro-zinc plated
- Used for longitudinally bracing lateral sway bracing against sway disturbance
- Also used for riser bracing



Part Number	A (Bracing Pipe Size) A x A1	B	B1
Electro-zinc Plated Finish			
TP2401000100EG	1" x 1"	1-3/8"	1-3/8"
TP2401000125EG	1" x 1-1/4"	1-3/8"	1-5/8"
Plain Finish			
TP2401000100PL	1" x 1"	1-3/8"	1-3/8"
TP2401000125PL	1" x 1-1/4"	1-3/8"	1-5/8"

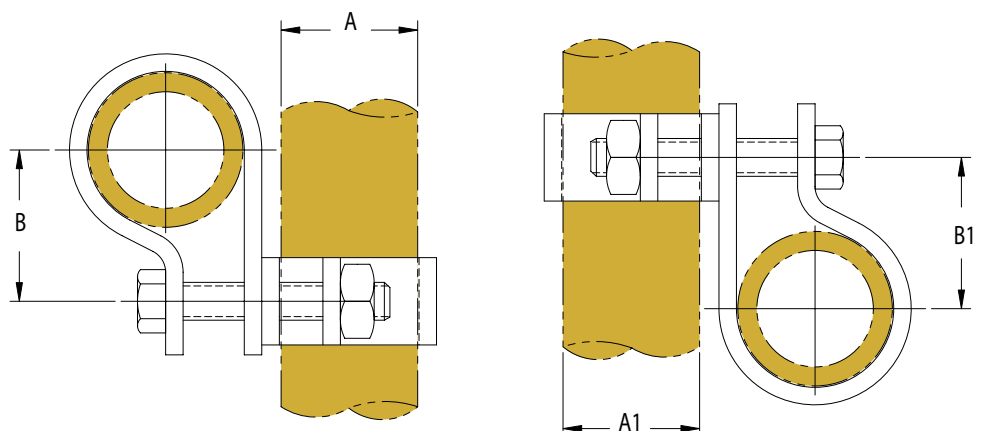

SWAY BRACING TP280

Threaded Sway Brace Fitting

- Size Range: 1" pipe
- Surface Finish: Black or Electro-zinc plated
- Used with Models: #400, #450, #610, and any length of 1" pipe to restrain pipe from swaying during an earthquake

NOTE: Electro-zinc plated available by special order



Part Number	Pipe Size	Style
Plain Finish		
TP2800100PL	1"	AB
TP280P0100PL	1"	A

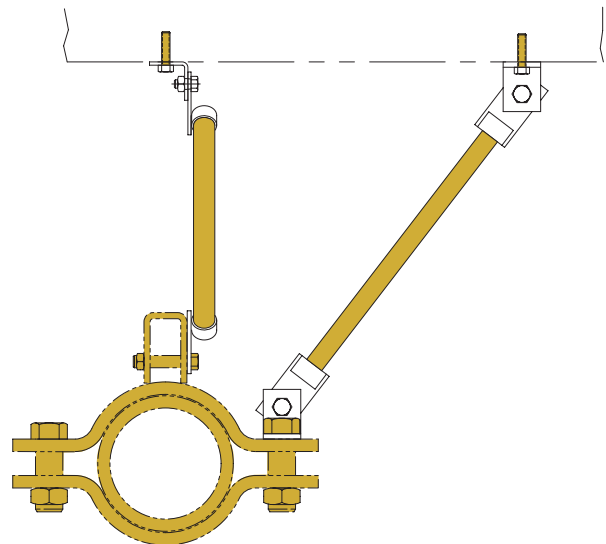
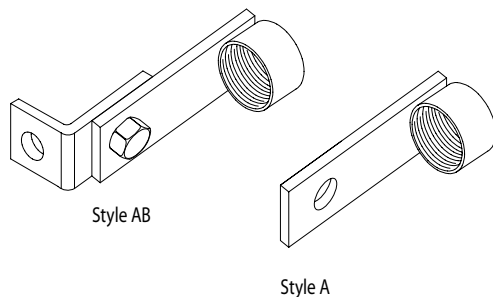

UL® LISTED LOAD CHART FOR ERICO® SWAY BRACES

Nominal ASTM Pipe Size	ASTM Schedule or Type*	Schedule 40 Sway Brace Pipe Size**	UL Min. Required Load-Ref. UL 203A***	ERICO Clamps UL Listed Loads (lbs)							
				Model TP220	Model TP220G	Model TP225	Model TP225G	Model TP230	Model TP230G	Model TP235	Model TP240
2"	10 - 40	1" or 1-1/4"	380	380	N/A	1100	3660	1575	N/A	1100	935
2-1/2"	10 - 40	1" or 1-1/4"	395	395	N/A	1100	3660	1575	N/A	1100	935
3"	10 - 40	1" or 1-1/4"	435	435	N/A	1100	3660	1575	N/A	1100	935
3-1/2"	10 - 40	1" or 1-1/4"	540	540	N/A	1100	3660	1575	N/A	1100	935
4"	10 - 40	1" or 1-1/4"	655	655	1740	1100	3660	N/A	3660	1100	935
5"	10 - 40	1" or 1-1/4"	935	935	1880	1100	3660	N/A	3660	1100	935
6"	10 - 40	1" or 1-1/4"	1265	N/A	2610	N/A	3660	N/A	3660	N/A	N/A
8"	10 - 40	1" or 1-1/4"	2015	N/A	3660	N/A	3660	N/A	3660	N/A	N/A

*ERICO Sway Braces are UL® tested and Listed for use with ASTM® schedule 10 through 40 brace pipe

**ERICO Sway Braces meet the full UL rated load when used with 1" or 1-1/4" schedule 40 brace pipe

***ERICO Sway Braces meet the UL requirement that lateral braces must support a load equal to 1-1/2 times the rated load without slippage



DIMENSIONAL LEGEND

A Adjustment	BS Bolt Size
CL Center Line	H Height
HS Hole Size	ID Inside Diameter
L Length	MRI Minimum Rod Insertion
OD Outside Diameter	PS Pipe Size
R Radius	RS Rod Size
T Thickness	W Width

MATERIAL USED

CAST IRON:

Grey Cast Iron, ANSI®/ASTM® A 48-76, Class #20

MALLEABLE IRON:

ANSI/ASTM A 47-77, Grade Number 32510

SPRING STEEL:

High Carbon Steel, tempered.

STAINLESS STEEL:

(S4) ANSI Type 304 Stainless Steel: (S6) ANSI Type 316, ASTM A240

STEEL:

- M1020 Merchant Bar Quality, ANSI/ASTM A 36
- Prime Quality, Low Carbon, Hot Rolled Sheet, (may be Pickled and Oiled) ANSI/ASTM A 569
- Commercial Quality, Low Carbon, Cold Rolled, ANSI/ASTM A 366

INSTALLATION

1. All pipe supports, hangers, intermediate components and structural attachments must **ONLY** be used to support pipe, tubing or conduit as stated herein and are **NEVER** to be used for any other purpose.
2. All pipe supports and hangers are designed **ONLY** for **STATIONARY** piping unless otherwise noted.
3. All supports, hangers, clamps and accessories shown to use two nuts on the hanger rod or a jam nut must have nuts tightened securely to assure proper performance.

FINISHES

Standard Finish on all products is plain without coating unless noted. Alternative finishes may be available upon request.

CADDY® COAT:

Electrostatic coating.

COPPER:

CP Copper electroplate (no corrosion protection; for identification purposes only).
(Alternate finish is CADDY COAT.)

EPOXY: EP

LAMINATE:

FL Felt Lined

PAINTED:

RO Red Oxide Primer
PT Painted (Color may vary)

PLAIN:

PL Plain without coating

POLYMER: (normally applied by fluidized bed process, 5 mil minimum thickness)

PVC (VC) Polyvinyl Chloride

ZINC:

EG Zinc electroplate (ANSI/ASTM B 633)

PRE-GAL (PG) Continuous mill annealed and galvanized. Cut edges and welded areas are not zinc coated. Zinc near the uncoated metal becomes a sacrificial anode which protects the bare areas after exposure (ANSI/ASTM A 525 and 526).
HDG (HD) Hot Dipped Galvanization after fabrication; submerged in a bath of molten zinc; forms a metallurgical bond covering all surfaces (ANSI/ASTM A 123).

ZP Zinc and Phosphate coatings combined to provide a corrosion resistant barrier to resist rusting in accordance with ASTM B117-61 Federal Test Number QQM-151.

All dimensions are in inches unless otherwise noted.

See page 263 for finish and material descriptions. All material is Electro-Galvanized Steel unless otherwise noted.



PIPE HANGER & SUPPORT RECOMMENDED SPECIFICATIONS

This specification has been compiled from generally accepted engineering principles and standards from the American National Standards Institute (ANSI®), Manufacturers Standardization Society (MSS), Factory Mutual (FM), Underwriters Laboratories (UL®) and other pertinent documents. The specification is intended as a guide only and it is the design engineers responsibility to use it in conjunction with the data found in this catalog to determine the best product or products for the user's application. The Model numbers are those of ERICO®.

I. MATERIAL DESIGN AND MANUFACTURE

All pipe hanger and supports shall be manufactured to comply with the latest edition of MSS-SP-58. Where applicable, design and manufacture of these products must also conform to ANSI/ASME® Code for Pressure Piping, B31.1; UL203 Standard for Pipe Hanger Equipment and Fire Protection Service; Factory Mutual FM1551 Approval Standard for Pipe Hanger Components for Automatic Sprinkler Systems; Metal Framing Manufacturers Association, MFMA-2 and Local Building Codes. Pipe hangers and supports shall be supplied by ERICO.

II. SELECTION

A. STANDARDS

All selection and installation of pipe supports shall conform to MSS-SP-69 and other specifications that may apply which are listed in this document.

B. LOAD CALCULATIONS

Hangers, supports, anchors and restraints must be selected to withstand all static and dynamic loading conditions which act upon the piping system and associated equipment. Piping supports and equipment must be considered as a total system and appropriate balance calculations made to determine load forces at critical stress points.

Loading conditions to be considered may include but are not limited to:

1. The total load of pipe, fittings, valves, insulation and any expected contents of the pipe.
2. Thermal expansion and contraction.
3. Stress from cycling of equipment or process.
4. Vibration transmitted to or from equipment or terminal connection.
5. Wind, snow or ice loading on outdoor piping.
6. Loading due to seismic forces if required by code or specification.

C. STRUCTURAL LOADS

Static and dynamic forces at points of attachment must be considered to help ensure structural integrity of buildings or equipment. Hanger and supports must be selected so as to minimize the effect of piping system loading on the structure.

D. MATERIALS

1. Appropriate materials and protective coatings shall be used to prevent failure from environmental and galvanic corrosion.
2. Material that comes in contact with pipe shall be compatible with piping material so that neither has a deteriorating effect on the other.

E. HANGER SPACING

The maximum allowable spacing for pipe hangers shall be in accordance with Hanger Locations and Spacing Table on page 254. Where concentrated loads of flanges, valves, fittings, etc. occur, or there are building structural loading limitations, close spacing will be necessary and shall be based on the weight to be supported and the maximum recommended loads for the pipe hangers.



PIPE HANGER & SUPPORT RECOMMENDED SPECIFICATIONS

F. PIPE ATTACHMENTS—HOT SYSTEMS

1. Hot systems are classified as those piping systems that have operating temperatures over 120°F (49°C).
2. Systems with operating temperatures over 450°F (232°C) require special designs for any hanger or support that is in direct contact with pipe. This is important in determining the raw materials needed as required by MSS SP-58. Maximum operating temperatures should be specified to the support manufacturer.
3. If piping is insulated, the connection of the pipe attachments to the hanger rod shall be outside the insulation so that movement of the line will not cause damage to the insulation.
4. Horizontal hot piping shall allow for expansion and contraction. If pipe movement is negligible, an ERICO® Model #1031 shall be used for pipe up thru 3". If pipe is supported from above and the movement is less than 4°, hanger components shall be selected to allow for swing using ERICO Models #450, #452 or #453 Pipe Clamps in conjunction with a Model #35 Forged Steel Eye Nut or Model #40W Welded Eye Rod. If the swing is greater than 4°, a traveling device should be provided for horizontal movement. If pipe is supported from above, ERICO Models # 605, #610, #612, or #620 Roller Hangers are to be used. For piping supported below, use ERICO #615, #617, #619 or #621 Roller Supports. ERICO Model #640 Pipe Slide Assembly may be utilized if low coefficients of friction are required on support piping. Models #630 thru #635 Protection Saddles should be tack welded to the pipe to protect the insulation from damage due to pipe movement and then filled with the specified insulating material.
5. Vertical hot piping requires a resilient support if significant movement occurs due to expansion and contraction of the pipe. Selection of the supports depends on the permissible load variation and effects on adjacent equipment. If vertical movement is negligible an ERICO Model #510 shall be used for steel pipe or a Model #511 shall be used for copper pipe. Use ERICO Variable Spring Hangers if supporting force must be limited to 6 percent and cannot be accommodated by a Variable Spring Hanger, Constant Support Hangers should be specified.

G. PIPE ATTACHMENTS—AMBIENT SYSTEMS

1. Ambient systems are classified as those piping systems that have operating temperatures between 60°F (16°C) and 119°F (48°C).
2. Horizontal piping systems shall be supported by ERICO Model #100 Swivel Loop Hanger for 1/2"-8" steel pipe and Model #400 Clevis Hanger for steel pipe 8" and larger. Copper pipe shall be supported by Model #102A PVC Coated Swivel Loop Hanger.
3. Vertical piping requires support at each floor by ERICO Model #510 Riser Clamp for steel pipe and Model #511 Riser Clamp for copper pipe. Also acceptable are U-bolts, ERICO Model #150 used with steel plates bolted securely to building structure or equipment framing.

H. PIPE ATTACHMENTS—COLD SYSTEMS

1. Cold systems are classified as those piping systems that have operating temperature below 60°F (16°C).
2. Hangers exposed to temperatures below -40°F (-40°C) require special design by the design engineer.
3. Horizontal piping requiring insulation shall be provided with vapor barriers. Under no circumstances shall supports or guides be applied directly to horizontal pipe or tubing on vapor barriered lines. Pipe shall be supported by ERICO Model #1031 Pre-Insulated Swivel Loop Hangers for pipe up to 3" and Model #4031 Pre-Insulated Clevis Hangers for pipe larger than 3". Pipe not requiring insulation shall be supported in the same manner as required for ambient temperature piping.
4. Vertical piping requirements are the same as required for ambient piping systems except that any penetration thru the vapor barrier will be covered by an approved method.



PIPE HANGER & SUPPORT RECOMMENDED SPECIFICATIONS

I. PIPE ATTACHMENTS – Plastic Pipe

1. Rigid plastic pipe (ABS, PVC, CPVC etc.) shall be supported by hangers with a welded-in support shield to spread the load bearing surface, ERICO® Model #103 for sizes through 6" pipe and ERICO® Model #403 on 8" pipe and larger.
2. Flexible plastic (polyethylene, etc.) shall be supported continuously by an 18 gauge sheet metal through ERICO Model #104 and #VTR.

J. PIPE ATTACHMENTS – Glass Pipe

Glass pipe shall be supported with a PVC cushioned wrought steel swivel loop hanger, ERICO Model #102.

K. SPECIALTY PIPING

Asbestos Cement, Reinforced Fiberglass or any other specialty piping shall be supported per the pipe manufacturer's recommendations.

L. INTERMEDIATE ATTACHMENTS

1. Where negligible movement of pipe occurs at hanger locations, the below listed minimum hanger rod sizes shall be used.

Nominal Pipe or Tubing Size	Minimum Rod Size
1/4" - 2"	3/8"
2-1/2" - 3-1/2"	1/2"
4" - 5"	5/8"
6"	3/4"
8" - 12"	7/8"
14" - 18"	1"
20" - 24"	1-1/4"

2. Where significant vertical movement of the pipe occurs at the support location, a resilient support shall be used. Selection of resilient supports shall be based on permissible variation and effects on adjacent equipment. Use ERICO Variable Spring Hangers or if supporting force must be limited to percent and cannot be accommodated by a Variable Spring Hanger, a Constant Support Spring Hanger should be specified.
3. The contractor shall furnish all miscellaneous hardware items designed to be utilized with various support components such as bolts, nuts, washers, turnbuckles, etc. All threads must use lock nuts or vibration resistant nuts where potential vibration may cause failure.



PIPE HANGER & SUPPORT RECOMMENDED SPECIFICATIONS

M. STRUCTURAL ATTACHMENTS

1. In general, piping shall be supported from walls, beams, columns and slabs using approved structural attachments. In situations where approved attachments cannot be used, alternative attachments or substructure assemblies must receive approval prior to installation. Prior approval must be given for any cutting or drilling of building structural steel. Damage to the structure through welding, cutting or drilling will not be permitted if it reduces the structures strength to a point below the established safety factor for said structure. Approvals may only be granted by a qualified structural engineer.
2. **BUILDING STEEL HORIZONTAL:**
For eccentric loading applications, utilize the ERICO® Model #300 Universal Beam attachments . For concentric loading, utilize the ERICO Model # 360 or #361 Center Load Beam Clamps.
3. **BUILDING STEEL VERTICAL**
Use ERICO Models: #352 or #353 Steel Wall Brackets where horizontal piping adjustment is necessary; where vertical piping adjustment is necessary use strut, ERICO Models: #A12, #B12 or #C14 with strut pipe clamps; Model #RIGD, or strut tubing clamps; Model #COPC.
4. **POURED CONCRETE CEILING, AND WALLS:**
Use accurately located spot inserts, ERICO Model #355 or Continuous Inserts Model # CONCT and place on forms before concrete is poured.
5. Where pre-set spot inserts cannot be in place before the pour, use expansions shields, ERICO Model #345 series, or as approved. No drilling of precast, pre-stressed concrete will be permitted. Special types of clamps which attach to the precast slab ribbing shall be provided as structural attachments.
6. Expansion loops and expansion joints shall have pipe guides, ERICO Models: #650 and #651 on each side of the loop or joint to maintain alignment. Each line that has this expansion potential shall be anchored to the structure at each change of direction.
7. Any additional structural steel required to properly support piping or equipment shall be furnished and installed under this contract.



PIPE HANGER & SUPPORT RECOMMENDED SPECIFICATIONS

N. HANGER LOCATIONS AND SPACING

1.

Nom. Pipe or Tube Dia.	Standard Weight Steel Pipe				Copper Tube			
	Water Service		Vapor Service		Water Service		Vapor Service	
	Ft	M*	Ft	M*	Ft	M*	Ft	M*
1/4"	7	2.1	8	2.4	5	1.5	5	1.5
3/8"	7	2.1	8	2.4	5	1.5	6	1.8
1/2"	7	2.1	8	2.4	5	1.5	6	1.8
3/4"	7	2.1	9	2.7	5	1.5	7	2.1
1"	7	2.1	9	2.7	6	1.8	8	2.4
1-1/4"	7	2.1	9	2.7	7	2.1	9	2.7
1-1/2"	9	2.7	12	3.7	8	2.4	10	3.0
2"	10	3.0	13	4.0	8	2.4	11	3.4
2-1/2"	11	3.4	14	4.3	9	2.7	13	4.0
3"	12	3.7	15	4.6	10	3.0	14	4.3
3-1/2"	13	4.0	16	4.9	11	3.4	15	4.6
4"	14	4.3	17	5.2	12	3.7	16	4.9
5"	16	4.9	19	5.8	13	4.0	18	5.5
6"	17	5.2	21	6.4	14	4.3	20	6.1
8"	19	5.8	24	7.3	16	4.9	23	7.0
10"	20	6.1	26	7.9	18	5.5	25	7.6
12"	23	7.0	30	9.1	19	5.8	28	8.5
14"	25	7.6	32	9.8	N/A	N/A	N/A	N/A
16"	27	8.2	35	10.7	N/A	N/A	N/A	N/A
18"	28	8.5	37	11.3	N/A	N/A	N/A	N/A
20"	30	9.1	39	11.9	N/A	N/A	N/A	N/A
24"	32	9.8	42	12.8	N/A	N/A	N/A	N/A
30"	33	10.4	44	13.4	N/A	N/A	N/A	N/A

*Meters

NOTE: These spacings do not apply where span calculations are made or where there are concentrated loads between supports such as flanges, valves, specialties, etc. or changes in direction requiring additional supports.

2. FIRE PROTECTION: follow requirements of National Fire Protection Assoc. NFPA® pamphlets 11, 12, 13, 14, 15, 16, 17.
3. CAST IRON PRESSURE: 12 feet (3.7 m) maximum spacing with a minimum of one (1) hanger per pipe section close to the joint on the barrel. Also at all change of directions and branch connections.
4. CAST IRON SOIL: 10 feet (3.0 m) maximum spacing with a minimum of one (1) hanger per section close to joint on the barrel. Also at change of direction and branch connection.
5. GLASS: 8 feet (2.4 m) maximum spacing, follow manufacturer's recommendations.
6. PLASTIC: follow pipe manufacturer's recommendations for material and service temperature.
7. FIBERGLASS REINFORCED: follow pipe manufacturer's recommendations for spacing and service condition.
8. NO SUB SOIL PIPE: horizontal piping shall be hung at every other joint except when the developed length between the hangers exceeds four (4) feet, the pipe shall be hung at each joint. Hangers shall be provided at each horizontal branch connection, on each water closet bend or elbow and at each trap. Where piping and fittings are suspended on hangers more than 18 inches long and on each water closet bend or elbow, rigid hangers or sway bracing shall be provided at every other hanger and hung piping and closet bends shall not have any horizontal movement in any direction. Hangers shall be placed within one inch of the coupling at each joint requiring a hanger. Vertical piping shall be supported at each floor level including slabs on grade with riser clamps.
9. In general, a hanger shall be used within one foot of each change of direction and at each valve or equipment connection.



PIPE HANGER & SUPPORT RECOMMENDED SPECIFICATIONS

O. SPECIAL SITUATIONS

1. Under Slab On Grade and Below Ground, if it is known at time of design that soil conditions at the job site are suitable for the support of underground piping, or if no information is available as to soil conditions, all piping shall be supported as specified under maximum pipe hanger and support spacing. Each support shall be constructed of masonry units, a minimum of two bricks wide by the diameter of the pipe, with the bottoms of the supports bearing on firm undisturbed soil.
2. In general, all special situations not specifically covered herein must be approved prior to installation.

P. ATTACHMENTS MADE BY WELDING

All welded type support components shall be in accordance with MSS-SP-58. All attachments welded to the pipe shall be in accordance with MSS-SP-58 and Pipe Fabrication Institute, Standard ES-26. Welded and bolted attachments to the building structural steel shall be in accordance with the requirements of AISC Specification for the Design, Fabrication and Erection of Structural Steel Buildings.

Q. THE FOLLOWING ARE NOT ACCEPTABLE OR PERMITTED

1. Wire hangers
2. Perforated strap
3. Hanging from unreinforced metal roof deck
4. Hanging from cellular roof deck
5. Wood plugs
6. Soft insulation at point of support on cold lines

(Sections N through Q were extracted from MSS SP-69, 1991, with permission of the publisher, The Manufacturer's Standardization Society).

Visit www.erico.com for the most current specifications.



PIPE HANGER & SUPPORT RECOMMENDED SPECIFICATIONS

CROSS REFERENCE MSS SPECIFICATION TO ERICO®

MSS Type No.	ERICO Model No.	MSS Type No.	ERICO Model No.
1	400, 401, 402, 410 404, 405, 406, 420, 427	29	N/A
2	N/A	30	360
3	452, 453	31	351
4	450, 451	32	352
5	418	33	353
6	111	34	325, 326, 327
7	105, 106	35	640
8	510, 511, 515, 520	36	720
9	1, 2, 3	37	721, 724
10	100, 101, 102, 102A, 115, 130	38	722, 723
11	N/A	39	630-635
12	455, 456, CADDY® SUPERFIX 454	40	125
13	30	41	605, 620
14	31	42	N/A
15	N/A	43	610, 612
16	47	44	615, 617
17	35	45	N/A
18	355	46	619
19	300, 301, 310	47	*
20	N/A	48	*
21	361	49	625
22	320	50	*
23	200, 255, 315	51	*
24	150, 151	52	*
25	367	53	*
26	470	54	*
27	363	55	*
28	N/A	56	*
		57	371
		58	*

*Contact ERICO for corresponding part number.



PIPE HANGER & SUPPORT RECOMMENDED SPECIFICATIONS

CROSS REFERENCE FEDERAL SPECIFICATION WW-H-171 TO ERICO®

WW-H-171 No.	ERICO Model No.
1	400, 400FL, 401, 405 406, 415, 420, 427
2	N/A
3	452, 453
4	450, 451
5	N/A
6	111
7	105, 106
8	510, 511, 515, 520
9	1, 2, 3
10	100, 100FL, 100JR, 101, 102, 102A, 115, 130
11	N/A
12	410, 410FL, 402
13	30
14	31
15	N/A
16	46
17	35
18	N/A
19	355
20	N/A
21	361, 364
22	320L
23	200, 255, 315, 300/300I, 310
24	150, 151
25	455, 456
26	470
27	N/A
28	N/A
29	N/A

WW-H-171 No.	ERICO Model No.
30	N/A
31	N/A
32	351
33	352
34	354
35	325, 326, 328
36	720, 723
37	720
38	721, 724
39	722, 723
40	630-635
41	125
42	605, 620
43	N/A
44	610, 612
45	615, 617
46	N/A
47	619
48	N/A
49	*
50	625
51	*
52	*
53	367
54	363
55	*
56	*
57	371
58	*
59	*

*Contact ERICO for corresponding part number.



PIPE HANGER & SUPPORT RECOMMENDED SPECIFICATIONS STEEL PIPE DATA (Schedule 40 & 80)

Nominal Pipe Size (Inches)	Sched. Number	OD of Pipe (Inches)	Wall Thickness (Inches)	Weight (lbs/ft)	Weight of Pipe filled w/Water (lbs/ft)
3/8	40	.675	.091	.567	.647
	80		.126	.738	.798
1/2	40	.840	.109	.850	.980
	80		.147	1.09	1.19
3/4	40	1.050	.113	1.13	1.36
	80		.154	1.47	1.66
1	40	1.315	.133	1.68	1.99
	80		.179	2.17	2.54
1-1/4	40	1.660	.140	2.27	2.92
	80		.191	3.00	3.56
1-1/2	40	1.900	.145	2.72	3.60
	80		.200	3.63	4.40
2	40	2.375	.154	3.65	5.10
	80		.218	5.02	6.30
2-1/2	40	2.875	.203	5.79	7.86
	80		.276	7.66	9.49
3	40	3.500	.216	7.58	10.78
	80		.300	10.25	13.11
3-1/2	40	4.000	.226	9.11	13.39
	80		.318	12.51	16.36
4	40	4.500	.237	10.79	16.30
	80		.337	14.98	19.96
5	40	5.563	.258	14.62	23.28
	80		.375	20.78	28.65
6	40	6.625	.280	18.98	31.49
	80		.432	28.57	39.86
8	40	8.625	.322	25.55	47.15
	80		.500	43.40	63.20
10	40	10.750	.365	40.50	74.60
	80		.593	64.74	95.84
12	40	12.750	.406	53.60	102.10
	80		.687	88.60	132.60
14	40	14.000	.437	63.37	121.87
	80		.750	107.00	158.20
16	40	16.000	.500	83.00	159.50
	80		.843	137.00	206.70
18	40	18.000	.563	105.00	202.20
	80		.937	171.00	259.50
20	40	20.000	.593	123.00	243.40
	80		1.031	209.00	318.40
24	40	24.000	.687	171.00	345.20
	80		1.218	297.00	455.20



PIPE HANGER & SUPPORT RECOMMENDED SPECIFICATIONS

STANDARD COPPER TUBING DATA

Nom. Size (Inches)	OD (Inches)	TYPE "K"			TYPE "L"		
		ID (Inches)	Weight (lbs/ft)	Wt. Filled With Water (lbs/ft)	ID (Inches)	Weight (lbs/ft)	Wt. Filled With Water (lbs/ft)
1/4	.375	.305	.145	.177	.315	.126	.160
3/8	.500	.402	.269	.275	.430	.198	.261
1/2	.625	.527	.344	.438	.545	.285	.385
5/8	.750	.652	.418	.563	.666	.362	.512
3/4	.875	.745	.641	.829	.785	.455	.667
1	1.125	.995	.839	1.176	1.025	.655	1.011
1-1/4	1.375	1.245	1.040	1.570	1.265	.884	1.427
1-1/2	1.625	1.481	1.360	2.109	1.505	1.140	1.889
2	2.125	1.959	2.060	3.364	1.985	1.750	3.092
2-1/2	2.625	2.435	2.930	4.927	2.465	2.480	4.539
3	3.125	2.907	4.000	6.870	2.945	3.330	6.263
3-1/2	3.625	3.385	5.120	9.051	3.425	4.290	8.284
4	4.125	3.857	6.510	11.564	3.905	5.380	10.559
5	5.125	4.805	9.670	17.532	4.875	7.610	15.697
6	6.125	5.741	13.900	25.132	5.845	10.200	21.806
8	8.125	7.583	25.900	45.494	7.725	19.300	39.580
10	10.125	9.449	40.300	70.689	9.625	30.100	61.612
12	12.125	11.315	57.800	101.355	11.565	40.400	85.890

**AWWA CAST IRON PIPE
(Class 150)**

Nominal Pipe Size (Inches)	OD of Pipe (Inches)	Wall Thickness (Inches)	Weight of Pipe (lbs/ft)	Weight of Pipe Filled w/Water (lbs/ft)
3	3.96	.32	12.19	15.92
4	4.80	.35	16.25	21.97
6	6.90	.38	25.63	38.43
8	9.05	.41	36.56	59.66
10	11.10	.44	48.44	73.94
12	13.20	.48	62.82	113.82
14	15.30	.51	78.75	148.05
16	17.40	.54	95.00	185.30
18	19.50	.58	114.69	228.69
20	21.60	.62	135.94	277.44
24	25.80	.73	190.31	391.31
30	32.00	.85	277.19	589.19
36	38.30	.94	365.90	814.90
42	44.50	1.05	475.30	1087.30
48	50.80	1.14	589.60	1392.60



PIPE HANGER & SUPPORT RECOMMENDED SPECIFICATIONS

SERVICE WEIGHT CAST IRON SOIL PIPE (Bell & Spigot Type)

Nominal Pipe Size (Inches)	OD of Pipe (Inches)	Wall Thickness (Inches)	Weight of Pipe (lbs/ft)	Weight of Pipe Filled w/Water (lbs/ft)
2	2.25	.17	4.0	5.5
3	3.25	.17	6.0	9.4
4	4.25	.18	8.0	14.2
5	5.25	.18	10.4	22.7
6	6.25	.18	13.0	26.9
8	8.38	.23	20.0	45.7
10	10.5	.28	29.0	69.6
12	12.5	.28	38.0	96.2
15	15.62	.31	51.0	147.6

Based on ASTM® A74

EXTRA WEIGHT CAST IRON SOIL PIPE (Bell & Spigot Type)

Nominal Pipe Size (Inches)	OD of Pipe (Inches)	Wall Thickness (Inches)	Weight of Pipe (lbs/ft)	Weight of Pipe Filled w/Water (lbs/ft)
2	2.38	.19	5.0	6.6
3	3.50	.25	9.0	12.7
4	4.50	.25	12.0	18.5
5	5.50	.25	15.0	25.2
6	6.50	.25	19.0	33.7
8	8.62	.31	30.0	56.1
10	10.75	.37	43.0	83.8
12	12.75	.38	54.0	112.8
15	15.88	.44	75.0	166.8

Based on ASTM A74

NO HUB CAST IRON SOIL PIPE

Nominal Pipe Size (Inches)	OD of Pipe (Inches)	Wall Thickness (Inches)	Weight of Pipe (lbs/ft)	Weight of Pipe Filled w/Water (lbs/ft)
1-1/2	1.90	.16	2.7	6.2
2	2.35	.16	3.6	8.6
3	3.35	.16	5.2	13.5
4	4.38	.19	7.4	20.2
5	5.30	.19	9.6	27.5
6	6.30	.19	11.0	34.0
8	8.38	.23	18.0	57.5

Based on ASTM A74



PIPE HANGER & SUPPORT RECOMMENDED SPECIFICATIONS

PVC PLASTIC PIPE

Nominal Pipe Size (Inches)	Schedule Number	OD of Pipe (Inches)	Wall Thickness (Inches)	Weight (lbs/ft)	Weight of Pipe Filled w/Water (lbs/ft)
1/8	40	.405	.068	.043	.068
	80		.095	.055	.071
1/4	40	.540	.088	.074	.119
	80		.119	.094	.125
3/8	40	.675	.091	.100	.183
	80		.126	.129	.190
1/2	40	.840	.109	.150	.282
	80		.147	.150	.251
3/4	40	1.050	.113	.199	.429
	80		.154	.295	.481
1	40	1.315	.133	.295	.669
	80		.179	.382	.693
1-1/4	40	1.660	.140	.400	1.047
	80		.191	.527	1.082
1-1/2	40	1.900	.145	.478	1.360
	80		.200	.639	1.404
2	40	2.375	.154	.643	2.095
	80		.218	.884	2.163
2-1/2	40	2.875	.203	1.020	3.092
	80		.276	1.350	3.184
3	40	3.500	.216	1.333	4.533
	80		.300	1.804	4.664
3-1/2	40	4.000	.226	1.598	5.878
	80		.318	2.195	6.045
4	40	4.500	.237	1.899	7.409
	80		.337	2.636	7.616
5	40	5.563	.258	2.770	11.430
	80		.375	4.126	11.996
6	40	6.625	.280	3.339	15.489
	80		.432	5.028	16.318
8	40	8.625	.322	5.280	26.880
	80		.500	8.023	27.823
10	40	10.750	.366	7.505	41.605
	80		.593	11.894	42.994
12	40	12.750	.406	10.023	58.523
	80		.687	16.365	60.365

GLASS PIPE DATA

REGULAR SCHEDULE				
Nominal Pipe Size (Inches)	OD of Pipe (Inches)	Wall Thickness (Inches)	Weight of Pipe (lbs/ft)	Weight of Pipe Filled w/Water (lbs/ft)
1-1/2	1.84	.12	.64	.89
2	2.34	.14	.94	1.45
3	3.41	.17	1.60	3.19
4	4.53	.20	2.60	5.79
6	6.66	.24	4.70	12.78
HEAVY SCHEDULE				
1	1.31	.16	.60	.95
1-1/2	1.84	.17	.87	1.63
2	2.34	.17	1.10	2.46
3	3.41	.20	2.00	5.06
4	4.53	.26	3.40	N/A
6	6.66	.33	6.30	N/A



PIPE HANGER & SUPPORT RECOMMENDED SPECIFICATIONS

SIZING CHARTS FOR INSULATION SHIELDS AND HANGERS for Model #: 103, 121, 122, 125, 403

FOR IRON PIPE

Nominal Pipe (Inches)		Insulation Thickness									
Size	OD	1/2"	3/4"	1"	1-1/2"	2"	2-1/2"	3"	3-1/2"	4"	4-1/2"
1/2	0.840	2	2	2-1/2	3-1/2	4-1/2	6	7	-	-	-
3/4	1.050	2	2-1/2	2-1/2	3-1/2	4-1/2	6	7	-	-	-
1	1.315	2	2-1/2	3	4	5	6	7	-	-	-
1-1/4	1.660	2-1/2	3	3	4-1/2	5	6	7	-	-	-
1-1/2	1.900	2-1/2	3	3-1/2	4-1/2	6	7	8	-	-	-
2	2.375	3	3-1/2	4	5	6	7	8	9	-	-
2-1/2	2.875	3-1/2	4	4-1/2	6	7	8	9	10	-	-
3	3.500	4	4-1/2	5	7	8	9	10	10	11	-
3-1/2	4.000	4-1/2	5	6	7	8	9	10	11	12	-
4	4.500	5	6	6	7	8	9	10	11	12	-
5	5.562	6	7	7	8	9	10	11	12	14	-
6	6.625	7	8	8	9	10	12	12	14	16	-
8	8.625	9	10	10	11	12	14	15	16	18	18
10	10.750	11	12	12	14	15	16	17	18	20	20
12	12.750	14	14	14	16	17	18	19	20	22	22

FOR COPPER TUBING

Nominal Tubing (Inches)		Insulation Thickness			
Size	OD	1/2"	3/4"	1"	1-1/2"
1/2	0.625	1-1/2	1-1/2	2-1/2	3-1/2
3/4	0.875	2	2	2-1/2	3-1/2
7/8	1.000	2	2-1/2	3	3-1/2
1	1.125	2	2-1/2	3	3-1/2
1-1/4	1.375	2	2-1/2	3	4
1-1/2	1.625	2-1/2	3	3-1/2	4-1/2
2	2.125	3	3-1/2	4	5
2-1/2	2.625	3-1/2	4	4	5
3	3.125	4	4-1/2	5	6
3-1/2	3.625	4-1/2	4-1/2	6	6
4	4.125	5	5	7	7
5	5.125	6	6	8	8
6	6.125	7	7	9	9



CADDY® ERISTRUT LOAD APPLICATIONS

CHANNEL FRAMING

CADDY® ERISTRUT channel and continuous inserts are cold roll-formed from high quality carbon steel. The raw steel used conforms to the following ASTM® specifications:

GAGE	FINISH	ASTM NO.
12	GR; HDG; PG	A570 GR33 A446 GRA
14	GR; HDG; PG	A570 GR33 A446 GRA

FINISHES

GREEN POWDER COATED (GN)

CADDY ERISTRUT green polyurethane powder coating is electrostatically applied after fabrication. Once the channel is pre-treated and cleaned, it is coated with the powder. It proceeds through a baking process creating a chemical bond, resulting in a 1.5 mil thickness of polyurethane coating. This coating provides excellent resistance to chipping, peeling, and corrosion.

PRE-GALVANIZED (PG)

The zinc coating on this channel is produced by hot dipping the steel coil or sheet at the mill prior to fabrication. This process is also known as "mill galvanized". The steel is then rolled and processed to produce various sizes and configurations of channel. During the fabrication of this product, the cut edges and welded areas are no longer zinc coated. However, the zinc near the uncoated metal provides sufficient protection to any bare areas. Pre-galvanized channel is suitable for use in dry or mildly corrosive atmospheres.

HOT DIP GALVANIZED (HD)

The zinc coating in this finish is applied after rolling and fabrication. The bond formed by dipping the finished product in molten zinc, completely covers all surfaces, including edges and welds. This zinc coating is recommended for prolonged outdoor exposure and will normally protect steel for up to 20 years or more. For best results, any field cuts should be treated with a zinc-rich paint to ensure the integrity of the finish.

STAINLESS STEEL (S4 OR S6)

CADDY ERISTRUT offers channel and accessories in AISI Type 304 or Type 316 stainless steel. Both are non magnetic. Stainless steel reduces long term maintenance costs, is ideal for use in extreme ambient temperatures and is resistant to corrosion.

ALUMINUM (AL)

Aluminum channel offers low installation costs through ease of handling and field cutting, while providing excellent corrosion resistance. All aluminum channels are extruded from aluminum alloy 6063-T6. Strut fittings are made from aluminum alloy 5052-H32.

PLAIN (PL)

The plain finish designation means that the channel retains the oiled surface applied to the steel prior to the rolling process. This channel offers no protection from corrosion.

FITTINGS

CADDY ERISTRUT fittings, unless otherwise noted, are punch pressed from hot rolled, pickled and oiled steel plates, strip or coil, and conform to ASTM specifications A575, A576, A635 and A36. The pickling of the steel provides a smooth scale-free surface.

HARDWARE

CADDY ERISTRUT's Channel nuts are designed to provide gripping power and ease during installation. Channel nuts are press formed, machined and hardened from steel that meets the requirements of ASTM A576, ASTM A675 and ASTM A108. Standard finish is electro-plated zinc (ASTM B663).

Channel nuts are rectangular with beveled end to permit quarter turn in the channel after insertion through the rolled opening. Toothed grooves engage the rolled edges of the channel and prevent movement of the nut after tightening of the bolt and nut. All bolts, screws and nuts meet the physical and chemical requirements of ASTM A307, SAE J429 and ASTM A563, as well as having unified inch screw threads (course, UNC). Metric threads are also available.

ELECTRO-PLATED ZINC (EG)

The Electro-plated Zinc process deposits a coating of zinc over the steel by electrolysis from a bath of zinc sales. EG finish is usually recommended for indoor use in relatively dry areas. Unless otherwise noted, the standard finish for all CADDY® ERISTRUT fittings and accessories is EG. This finish conforms with ASTM B633 SC1.



CADDY® ERISTRUT LOAD APPLICATIONS

USING CADDY ERISTRUT LOAD TABLES

The calculation for beam loading on a piece of strut or a beam supported on both ends with a uniformly distributed load is based on the following equations taken from "Machinery's Handbook, 26th edition":

$$\text{Stress at center (worst case)} = -\frac{WL}{8Z} \quad [\text{eq. 1}]$$

$$\text{Maximum deflection at center} = \frac{5}{384} * \frac{WL^3}{EI} \quad [\text{eq. 2}]$$

W = Load value evenly distributed over the strut (maximum supplied by the manufacturer)

Z = Section modulus (calculated or supplied by the manufacturer)

E = Modulus of elasticity of the material (29,000,000 psi for commercial grade steel)

I = Moment of inertia of the cross section of the strut (calculated or supplied by the manufacturer)

L = Length of strut

Selecting the CADDY ERISTRUT Profile

Typically the capacity ratings for strut are listed for an evenly distributed load as shown above. Although this case may be rare for pipe support applications, it does provide a baseline from which the acceptable load for a given piping layout can be obtained. The figures listed in the load tables are based on a yield stress rating for steel. CADDY® ERISTRUT uses 25,000 psi as the maximum stress allowed in the strut member.

The most commonly asked question concerning beam design for strut is how are the loads calculated if a point load or several point loads are applied instead of a uniformly distributed load. This can be derived from the supplied information using simple conversion numbers derived from the formulas in "Machinery's Handbook." A sample of the calculation used for the listed, evenly distributed load and a single-point load is shown in the next equation.

$$\text{Point load stress} = \frac{WL}{4Z}$$

$$\text{Evenly distributed load stress} = \frac{WL}{8Z}$$

$$\frac{\text{Evenly distributed load stress}}{\text{Point load stress}} = \frac{1}{2} = 0.50$$

The comparison formula shows the stress is doubled and the allowable load cut in half when applying a point load instead of an evenly distributed load. This is case 2 on the Loading Application Tables. Other load factors are also shown. Simply apply the load factor for the appropriate case to the maximum loads shown in the catalog to obtain the maximum load for the situation. The load used in the calculation should include a factor of safety appropriate for the application in which the strut is being used.

Consider an applied load of 250 lb. (AL) as a point load to the center of a 24-in. section of strut. Assume that the strut has half slots and the required factor of safety (FS) is 3. First, determine the appropriate hole factor (HF) and load factor (LF) from the Load Application Table. Then calculate the design load.

$$\text{Design load} = \frac{AL * FS}{LF * HF} = \frac{250 \text{ lb.} * 3}{0.5 * 0.9} = 1667 \text{ lb.}$$

Next, in the load tables, find the strut section which has a uniform load rating higher than the design load for a 24 inch section. Note that A12 allows 1692 lb. for a 24 inch section. If no strut sections will support the design load, a different support configuration may need to be selected.

Deflection Calculations

The maximum allowable deflection is based on an industry standard of the length of the member divided by 240. For a 24-in. section of channel, this would yield an allowable deflection of 0.10-in. These values are listed in the load tables. (For A12 strut, the deflection for a simply supported beam with uniform load of 250 lb. using equation 2 is:)

$$\text{Uniform Load Deflection (ULD)} = \frac{5}{384} * \frac{WL^3}{EI} =$$

$$\frac{5 * 250 \text{ lb.} * (24 \text{ in})^3}{384 * 29,000,000 \text{ lb. in}^2 * 0.188 \text{ in}^4} = 0.008 \text{ in.}$$



All dimensions are in inches unless otherwise noted. See page 263 for finish and material descriptions. All material is Electro-Galvanized Steel unless otherwise noted.

CADDY® ERISTRUT LOAD APPLICATIONS

In order to determine the deflection for other loading cases, multiply the deflection amount for the uniform loading case by the deflection factor found in the Load Application Chart. An allowance must be made for channel that is punched with slots or holes. For a simply supported beam with full slots and a concentrated load in the center of the span, where:

$$\text{Deflection} = \text{ULD} * \text{DF} \div \text{HF} = \frac{0.008 \text{ in.} * 1.6}{.90} = 0.014 \text{ in.}$$

$$\text{Allowable Deflection} = \frac{L}{240} = \frac{24 \text{ in.}}{240} = 0.10 \text{ in.}$$

Note that this deflection is within the recommended range. If it is not, another beam or another support configuration should be selected.

ULD = Uniform Load Deflection (see calculation pg. 264)

DF = Deflection Factor (see Table pg. 265-266)

HF = Hole Factor (see Table pg. 266)

LF = Load Factor (see Table pg. 265-266)

Factor of Safety Calculations



CADDY® ERISTRUT uses 25,000 psi as the maximum stress allowed in the strut member. Considering a 1-5/8" X 1-5/8" piece of 12 gauge channel (CADDY® ERISTRUT Model A12) two (2) feet in length with an applied load of 250 lb. Using Equation 1 we find the values of:

$$\text{Stress} = \frac{WL}{8Z} = \frac{250 \text{ lb.} * 24 \text{ in.}}{8 * 0.203 \text{ in.}^3} = 3695 \text{ psi.}$$

Since our example is for a point load, the stress will be doubled per the Load Application Chart.

$$\text{Factor of safety} = \frac{\text{LF} * \text{HF} * 25,000 \text{ psi.}}{\text{Actual Stress}} = \frac{0.5 * 0.9 * 25,000}{3695} = 3$$

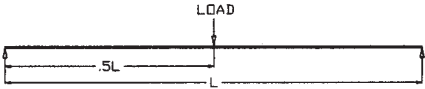
The figures on these pages illustrate the load applications and the derived conversion factors. These factors multiplied by the load ratings listed on pages 268-274 will give the maximum recommended load in that application for the type of CADDY ERISTRUT being used.

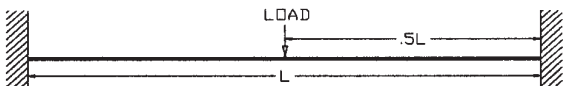

Loading Application	Load Factor (LF)	Deflection Factor (DF)
Simple beam with a uniformly applied load and supported at each end 	1.00	1.00
Simple beam with a concentrated load at center and supported at each end 	0.50	1.60
Simple beam with 2 equal concentrated loads at 1/4 total length from ends and supported at each end. 	1.00	1.10
Beam fixed at both ends with a uniformly applied load 	1.50	0.20
Beam fixed at both ends with a concentrated load at center 	1.00	0.40

All dimensions are in inches unless otherwise noted.

See page 263 for finish and material descriptions. All material is Electro-Galvanized Steel unless otherwise noted.

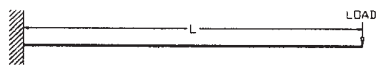
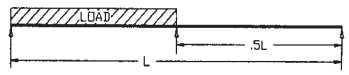
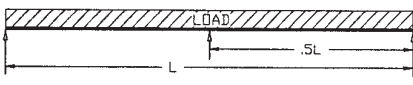
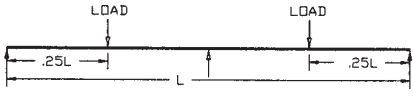
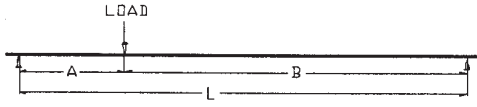

CADDY® ERISTRUT LOAD APPLICATIONS

Loading Application	Load Factor (LF)	Deflection Factor (DF)
Cantilever Beam with a uniform load. 	0.25	9.60
Cantilever beam with a concentrated load at the end or at any point along the length. 	0.12	25.60
Continuous beam over 2 equal spans with a uniform load on one span. 	1.30	0.71
Continuous beam over 2 equal spans with a uniform load on both spans. 	1.00	0.42
Continuous beam over 2 equal spans with a concentrated load at the center of both spans. 	0.67	0.72
A beam supported at both ends with 2 symmetrical loads at the same distance from the end. 	$\frac{L^2}{8 * A * B}$	Contact ERICO®
A beam supported at both ends with 2 symmetrical loads each the same distance from each end. 	$\frac{2 * L}{8 * A}$	Contact ERICO

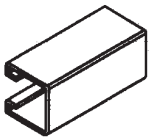
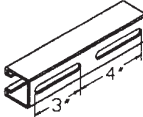
Hole Type	Sample	Hole Factor (HF)
None or Solid		1.00
Full Slot		0.90

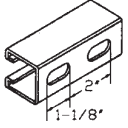
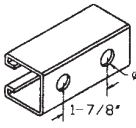
Hole Type	Sample	Hole Factor (HF)
Half Slot		0.92
Punched		0.92

All dimensions are in inches unless otherwise noted.
 See page 263 for finish and material descriptions. All material is Electro-Galvanized Steel unless otherwise noted.



CADDY® ERISTRUT CHANNEL

Selection Chart

Model No.	Width (Inches)	Height (Inches)	Gauge
A12	1-5/8	1-5/8	12
A14	1-5/8	1-5/8	14
B12	1-5/8	1-3/8	12
C12	1-5/8	13/16	12
C14	1-5/8	13/16	14
D12	1-5/8	2-7/16	12
E12	1-5/8	3-1/4	12
M12	1-5/8	1	12



HALF SLOT (H)

1-1/8" x 9/16" slots, punched 2" on center

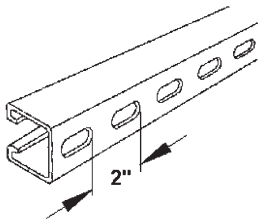

SLOT (S)

3" x 7/16" slots, punched 4" on center

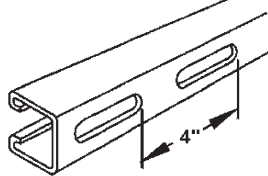

PUNCH (P)

9/16" holes, punched 1-7/8" on center

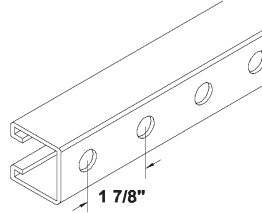

KNOCKOUT (K)

1/2" knockout (7/8"), located 6" on center

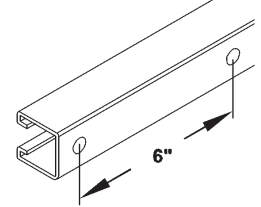

WELDED

Two or more lengths spot welded together. ("A" configuration shown.)

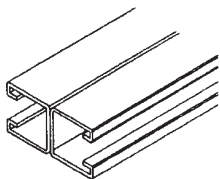

WELDED Configurations

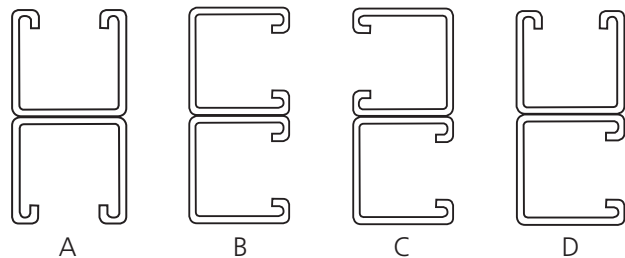

(Special configurations available upon request.)

All dimensions are in inches unless otherwise noted. See page 263 for finish and material descriptions. All material is Electro-Galvanized Steel unless otherwise noted.



CADDY® ERISTRUT A12 CHANNEL

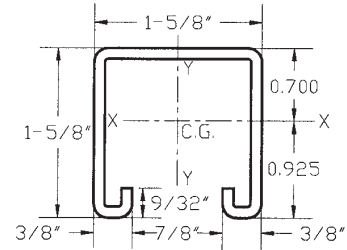
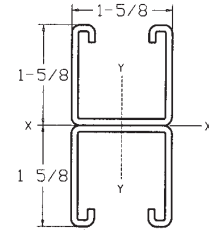
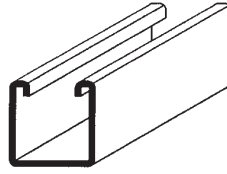

ELEMENTS OF SECTION								
Channel Part No.	Weight lbs/ft	Area of Section in ²	Axis x-x			Axis y-y		
			I (in ⁴)	Z (in ³)	r (in)	I (in ⁴)	Z (in ³)	r (in)
A12	1.890	.583	.188	.203	.581	.257	.316	.680
A12A	3.780	1.166	.920	.566	.910	.514	.634	.680

I = moment of inertia Z = section modulus r = radius of gyration

BEAM AND COLUMN LOADS DATA					
Channel Part No.	BEAM SPAN or Unbraced Column Height (inches)	UNIFORM LOAD at Stress of 25,000 psi (lbs.)	DEFLECTION at Stress of 25,000 psi (lbs.)	UNIFORM LOAD (lbs.) when Maximum Deflection = $\frac{\text{span}}{240}$	Maximum Allowable Load of Column (lbs.)
A12 UL® Listed	18	2256	.031	2256	9481
	24	1692	.056	1692	8582
	30	1353	.087	1353	7601
	36	1128	.126	1128	6595
	42	967	.171	967	5595
	48	846	.223	757	4718
	54	752	.283	598	4090
	60	677	.349	485	3616
	72	564	.503	337	2936
	84	483	.684	247	2461
	96	423	.894	189	2101
	108	376	1.131	150	1816
120	338	1.396	121	1583 **	
A12A	18	6289	.018	6289	21239
	24	4717	.032	4717	20819
	30	3773	.050	3773	20279
	36	3144	.072	3144	19619
	42	2695	.097	2695	18840
	48	2358	.127	2358	17940
	54	2096	.161	2096	16920
	60	1887	.199	1887	15781
	72	1572	.286	1572	13141
	84	1348	.390	1210	10076
	96	1179	.509	926	7715
	108	1048	.644	732	6096
120	943	.796	593	4937	

BEAM LOADS – Loads listed are uniformly distributed. When deflection is not a factor, use stress of 25,000 psi. When deflection is a factor, use deflection of $\frac{\text{span}}{240}$.

** $\frac{KL}{r}$ exceeds 200

COLUMN LOADS – Loads listed are for unbraced height, K = 1.0. Modulus of elasticity = 29,000,000 psi.

NOTE: Must specify length, finish, and hole configuration when ordering

All dimensions are in inches unless otherwise noted. See page 263 for finish and material descriptions. All material is Electro-Galvanized Steel unless otherwise noted.



CADDY® ERISTRUT A14 CHANNEL

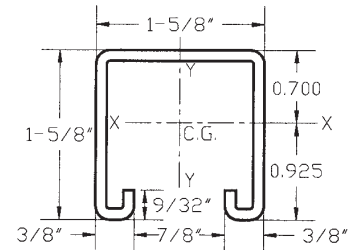
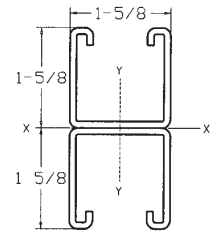
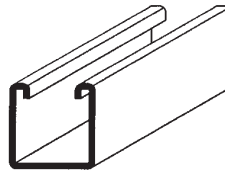

ELEMENTS OF SECTION								
Channel Part No.	Weight lbs/ft	Area of Section in ²	Axis x-x			Axis y-y		
			I (in ⁴)	Z (in ³)	r (in)	I (in ⁴)	Z (in ³)	r (in)
A14	1.350	.398	.142	.155	.597	.177	.215	.655
A14A	2.700	.796	.685	.421	.927	.354	.430	.655

I = moment of inertia Z = section modulus r = radius of gyration

BEAM AND COLUMN LOADS DATA					
Channel Part No.	BEAM SPAN or Unbraced Column Height (inches)	UNIFORM LOAD at Stress of 25,000 psi (lbs.)	DEFLECTION at Stress of 25,000 psi (lbs.)	UNIFORM LOAD (lbs.) when Maximum Deflection = $\frac{\text{span}}{240}$	Maximum Allowable Load of Column (lbs.)
A14 UL® Listed	18	1722	.032	1722	6058
	24	1292	.056	1292	5483
	30	1033	.088	1033	4958
	36	861	.127	861	4302
	42	738	.173	738	3571
	48	646	.226	572	3008
	54	574	.286	452	2488
	60	517	.353	366	2200
	72	431	.506	254	1740
	84	369	.692	187	1444
	96	323	.903	143	1236
	108	287	1.143	113	1078
120	258	1.411	92	953 **	
A14A	18	4678	.018	4678	13085
	24	3508	.032	3508	12828
	30	2807	.050	2807	12667
	36	2339	.072	2339	12256
	42	2005	.097	2005	12031
	48	1754	.127	1754	11456
	54	1559	.161	1559	11179
	60	1403	.199	1403	10427
	72	1169	.286	1169	9169
	84	1002	.389	901	7683
	96	877	.509	690	6024
	108	780	.644	545	4760
120	702	.796	441	3856	

BEAM LOADS – Loads listed are uniformly distributed.
 When deflection is not a factor, use stress of 25,000 psi.
 When deflection is a factor, use deflection of $\frac{\text{span}}{240}$

** $\frac{KL}{r}$ exceeds 200

COLUMN LOADS – Loads listed are for unbraced height, K = 1.0
 Modules of elasticity = 29,000,000 psi.

NOTE: Must specify length, finish, and hole configuration when ordering

All dimensions are in inches unless otherwise noted.
 See page 263 for finish and material descriptions. All material is Electro-Galvanized Steel unless otherwise noted.



CADDY® ERISTRUT B12 CHANNEL

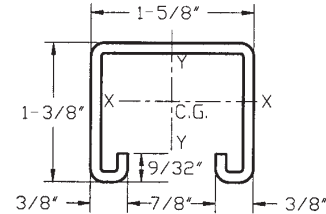
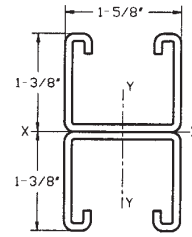
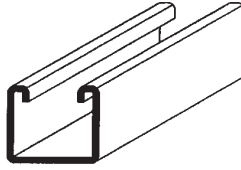

ELEMENTS OF SECTION								
Channel Part No.	Weight lbs/ft	Area of Section in ²	Axis x-x			Axis y-y		
			I (in ⁴)	Z (in ³)	r (in)	I (in ⁴)	Z (in ³)	r (in)
B12	1.704	.500	.134	.168	.517	.219	.269	.662
B12A	3.408	1.000	.602	.438	.775	.438	.538	.662

I = moment of inertia Z = section modulus r = radius of gyration

BEAM AND COLUMN LOADS DATA					
Channel Part No.	BEAM SPAN or Unbraced Column Height (inches)	UNIFORM LOAD at Stress of 25,000 psi (lbs.)	DEFLECTION at Stress of 25,000 psi (lbs.)	UNIFORM LOAD (lbs.) when Maximum Deflection = $\frac{\text{span}}{240}$	Maximum Allowable Load of Column (lbs.)
B12 UL® Listed	18	1867	.036	1867	9266
	24	1400	.065	1400	8387
	30	1120	.101	1120	7514
	36	933	.146	933	6520
	42	800	.199	705	5672
	48	700	.259	540	4778
	54	622	.328	426	4177
	60	560	.405	345	3693
	72	467	.584	240	2994
	84	400	.794	176	2489
	96	350	1.038	135	1993
	108	311	1.313	107	1574 **
120	280	1.621	86	1275 **	
B12A	18	4867	.021	4867	20831
	24	3650	.038	3650	20421
	30	2920	.059	2920	19724
	36	2433	.085	2433	19083
	42	2086	.115	2086	18073
	48	1825	.151	1825	17210
	54	1622	.191	1622	15869
	60	1460	.235	1460	14801
	72	1217	.339	1078	11858
	84	1043	.461	792	8798
	96	913	.602	606	6736
	108	811	.762	479	5322
120	730	.941	388	4311	

BEAM LOADS – Loads listed are uniformly distributed.
 When deflection is not a factor, use stress of 25,000 psi.
 When deflection is a factor, use deflection of $\frac{\text{span}}{240}$

** $\frac{KL}{r}$ exceeds 200

COLUMN LOADS – Loads listed are for unbraced height, K = 1.0
 Modules of elasticity = 29,000,000 psi.

NOTE: Must specify length, finish, and hole configuration when ordering

All dimensions are in inches unless otherwise noted.
 See page 263 for finish and material descriptions. All material is Electro-Galvanized Steel unless otherwise noted.



CADDY® ERISTRUT C12 CHANNEL

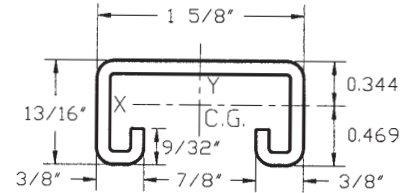
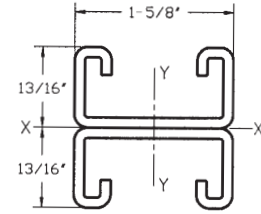
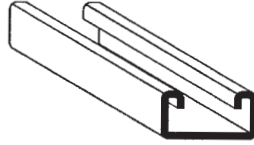

ELEMENTS OF SECTION								
Channel Part No.	Weight lbs/ft	Area of Section in ²	Axis x-x			Axis y-y		
			I (in ⁴)	Z (in ³)	r (in)	I (in ⁴)	Z (in ³)	R (in)
C12	1.350	.389	.030	.061	.278	.145	.179	.616
C12A	2.700	.766	.142	.175	.431	.290	.357	.616

I = moment of inertia Z = section modulus r = radius of gyration

BEAM AND COLUMN LOADS DATA					
Channel Part No.	BEAM SPAN or Unbraced Column Height (inches)	UNIFORM LOAD at Stress of 25,000 psi (lbs.)	DEFLECTION at Stress of 25,000 psi (lbs.)	UNIFORM LOAD (lbs.) when Maximum Deflection = $\frac{\text{span}}{240}$	Maximum Allowable Load of Column (lbs.)
C12	18	678	.059	678	7204
	24	508	.105	483	6521
	30	407	.164	309	4167
	36	339	.237	215	3616
	42	290	.322	158	2415
	48	254	.421	121	2034
	54	226	.532	95	1473
	60	203	.657	77	1302 **
	72	169	.947	54	904 **
	84	145	1.288	39	664 **
	96	127	1.683	30	—
108	113	2.130	24	—	
120	102	2.629	19	—	
C12A	18	1944	.036	1944	16741
	24	1458	.064	1458	16412
	30	1167	.100	1167	13825
	36	972	.143	972	13376
	42	833	.195	747	10169
	48	729	.255	572	9683
	54	648	.323	452	6699
	60	583	.398	366	6248
	72	486	.574	254	4339
	84	417	.781	187	3188
	96	365	1.020	143	2441 **
108	324	1.291	113	1928 **	
120	292	1.594	92	1562 **	

BEAM LOADS – Loads listed are uniformly distributed.
 When deflection is not a factor, use stress of 25,000 psi.
 When deflection is a factor, use deflection of $\frac{\text{span}}{240}$

** $\frac{KL}{r}$ exceeds 200

COLUMN LOADS – Loads listed are for unbraced height, K = 1.0
 Modules of elasticity = 29,000,000 psi.

NOTE: Must specify length, finish, and hole configuration when ordering

All dimensions are in inches unless otherwise noted.
 See page 263 for finish and material descriptions. All material is Electro-Galvanized Steel unless otherwise noted.



CADDY® ERISTRUT C14 CHANNEL

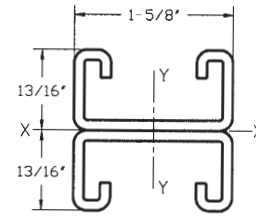
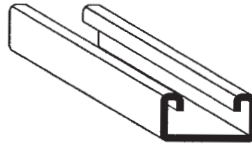

ELEMENTS OF SECTION								
Channel Part No.	Weight lbs/ft	Area of Section in ²	Axis x-x			Axis y-y		
			I (in ⁴)	Z (in ³)	r (in)	I (in ⁴)	Z (in ³)	r (in)
C14	1.000	.275	.028	.060	.319	.116	.142	.649
C14A	2.000	.550	.121	.149	.469	.232	.284	.649

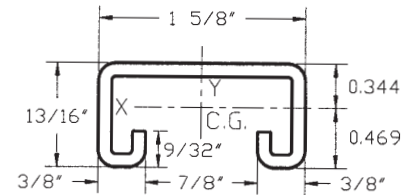

I = moment of inertia Z = section modulus r = radius of gyration

BEAM AND COLUMN LOADS DATA					
Channel Part No.	BEAM SPAN or Unbraced Column Height (inches)	UNIFORM LOAD at Stress of 25,000 psi (lbs.)	DEFLECTION at Stress of 25,000 psi (lbs.)	UNIFORM LOAD (lbs.) when Maximum Deflection = $\frac{\text{span}}{240}$	Maximum Allowable Load of Column (lbs.)
C14	18	667	.062	667	5488
	24	500	.111	451	4968
	30	400	.173	289	3545
	36	333	.249	200	3076
	42	286	.339	147	2053
	48	250	.443	113	1730
	54	222	.561	59	1252
	60	200	.693	72	1107 **
	72	167	.998	50	769 **
	84	143	1.358	37	565 **
C14A	18	1656	.036	1656	11897
	24	1242	.064	1242	11663
	30	993	.100	993	10362
	36	828	.143	828	10026
	42	710	.195	637	8122
	48	621	.255	487	7734
	54	552	.322	385	5504
	60	497	.398	312	5134
	72	414	.573	217	3566
	84	355	.780	159	2620
96	310	1.019	122	2006 **	
108	276	1.290	96	1585 **	
120	248	1.592	78	1284 **	

BEAM LOADS – Loads listed are uniformly distributed. When deflection is not a factor, use stress of 25,000 psi. When deflection is a factor, use deflection of $\frac{\text{span}}{240}$

** $\frac{KL}{r}$ exceeds 200

COLUMN LOADS – Loads listed are for unbraced height, K = 1.0. Modulus of elasticity = 29,000,000 psi.

NOTE: Must specify length, finish, and hole configuration when ordering

All dimensions are in inches unless otherwise noted. See page 263 for finish and material descriptions. All material is Electro-Galvanized Steel unless otherwise noted.



CADDY® ERISTRUT D12 CHANNEL

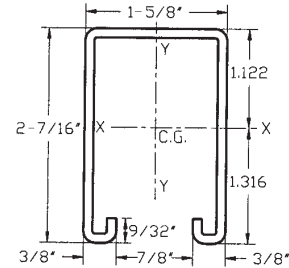
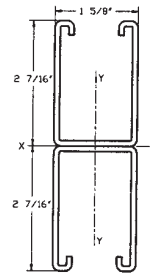
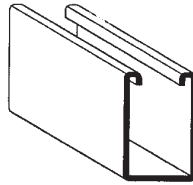

ELEMENTS OF SECTION								
Channel Part No.	Weight lbs/ft	Area of Section in ²	Axis x-x			Axis y-y		
			I (in ⁴)	Z (in ³)	r (in)	I (in ⁴)	Z (in ³)	r (in)
D12	2.470	.725	.520	.395	.847	.337	.415	.682
D12A	4.940	1.450	2.865	1.175	1.405	.674	.830	.682

I = moment of inertia Z = section modulus r = radius of gyration

BEAM AND COLUMN LOADS DATA					
Channel Part No.	BEAM SPAN or Unbraced Column Height (inches)	UNIFORM LOAD at Stress of 25,000 psi (lbs.)	DEFLECTION at Stress of 25,000 psi (lbs.)	UNIFORM LOAD (lbs.) when Maximum Deflection = $\frac{\text{span}}{240}$	Maximum Allowable Load of Column (lbs.)
D12	18	4389	.022	4389	9533
	24	3292	.039	3292	8629
	30	2633	.061	2633	7821
	36	2194	.088	2194	6786
	42	1881	.120	1881	5680
	48	1646	.157	1646	4785
	54	1463	.199	1463	3984
	60	1317	.246	1317	3523
	72	1097	.354	931	2806
	84	940	.481	684	2345
D12A	18	13056	.012	13056	20500
	24	9792	.021	9792	20293
	30	7833	.033	7833	19801
	36	6528	.048	6528	19509
	42	5595	.065	5595	18860
	48	4896	.085	4896	18412
	54	4352	.107	4352	17607
	60	3917	.133	3917	17002
	72	3264	.191	3264	15278
	84	2798	.260	2798	13240
	96	2448	.339	2448	10889
	108	2176	.430	2176	8610
	120	1958	.530	1846	6974

BEAM LOADS – Loads listed are uniformly distributed.
 When deflection is not a factor, use stress of 25,000 psi.
 When deflection is a factor, use deflection of $\frac{\text{span}}{240}$

COLUMN LOADS – Loads listed are for unbraced height, K = 1.0

NOTE: Must specify length, finish, and hole configuration when ordering

All dimensions are in inches unless otherwise noted.
 See page 263 for finish and material descriptions. All material is Electro-Galvanized Steel unless otherwise noted.



CADDY® ERISTRUT E12 CHANNEL

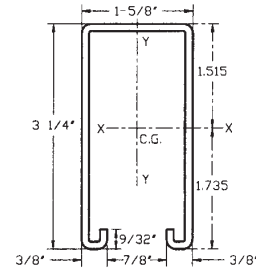
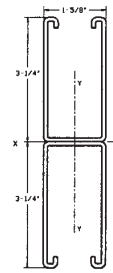
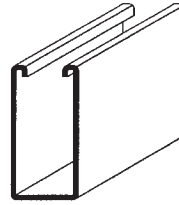

ELEMENTS OF SECTION								
Channel Part No.	Weight lbs/ft	Area of Section in ²	Axis x-x			Axis y-y		
			I (in ⁴)	Z (in ³)	r (in)	I (in ⁴)	Z (in ³)	r (in)
E12	3.060	.898	1.111	.640	1.112	.438	.539	.698
E12A	6.120	1.796	6.344	1.920	1.879	.876	1.078	.698

I = moment of inertia Z = section modulus r = radius of gyration

BEAM AND COLUMN LOADS DATA					
Channel Part No.	BEAM SPAN or Unbraced Column Height (inches)	UNIFORM LOAD at Stress of 25,000 psi (lbs.)	DEFLECTION at Stress of 25,000 psi (lbs.)	UNIFORM LOAD (lbs.) when Maximum Deflection = $\frac{\text{span}}{240}$	Maximum Allowable Load of Column (lbs.)
E12	18	7111	.017	7111	8598
	24	5333	.030	5333	7783
	30	4267	.047	4267	7495
	36	3556	.067	3556	6503
	42	3048	.091	3048	5921
	48	2667	.119	2667	4988
	54	2370	.151	2370	4066
	60	2133	.186	2133	3595
	72	1778	.268	1778	2790
	84	1524	.365	1461	2291
	96	1333	.477	1119	1953
	108	1185	.603	884	1708
120	1067	.745	716	1522	
E12A	18	21333	.009	21333	17925
	24	16000	.016	16000	17572
	30	12800	.024	12800	17331
	36	10667	.035	10667	17127
	42	9143	.048	9143	16715
	48	8000	.063	8000	16503
	54	7111	.079	7111	16102
	60	6400	.098	6400	15701
	72	5333	.141	5333	14721
	84	4571	.192	4571	13563
	96	4000	.250	4000	12226
	108	3556	.317	3556	10712
120	3200	.391	3200	9019	

BEAM LOADS – Loads listed are uniformly distributed.
 When deflection is not a factor, use stress of 25,000 psi.
 When deflection is a factor, use deflection of $\frac{\text{span}}{240}$

COLUMN LOADS – Loads listed are for unbraced height, K = 1.0

NOTE: Must specify length, finish, and hole configuration when ordering

All dimensions are in inches unless otherwise noted.
 See page 263 for finish and material descriptions. All material is Electro-Galvanized Steel unless otherwise noted.



INDEX

Part No.	Page	Part No.	Page	Part No.	Page	Part No.	Page
740	237	0080150CP	48	0110075PL	222	035RS0800EG	110
389001	51	0080150EG	46	0110087EG	222	035RS1000EG	110
389002	51	0080200CP	48	0110087PL	222	035RS1200EG	110
389003	51	0080200EG	46	0120025EG	222	035RS1400EG	110
389004	51	0080250EG	46	0120037EG	222	035RS1600EG	110
389005	51	0080300EG	46	0120050EG	222	035RS1800EG	110
389006	51	0080400EG	46	0150037PC	236	035RS2000EG	110
389007	51	008CU0025PL	48	0150037W	236	0370037EG	121
389008	51	008CU0037PL	48	0150050W	236	0370050EG	121
389011	51	008CU0050PL	48	0250025EG	224	0380037EG	122
389012	51	008CU0075PL	48	0250037EG	224	0403704PL	233
389013	51	008CU0100PL	48	0250050EG	224	0403706PL	233
389014	51	008CU0125PL	48	0250062EG	224	0403708PL	233
454001	14	008CU0150PL	48	0250075EG	224	0413704PL	226
454002	14	008CU0200PL	48	0250087EG	225	0413706PL	226
454003	14	0097524CP	70	025R3725EG	225	0413708PL	226
454004	14	0097524CU	71	025R5037EG	225	0413710PL	226
454005	14	0097524EG	70	025R6250EG	225	0413712PL	226
454006	14	0100025EG	221	025S0037EG	225	0415004PL	226
454007	14	0100025PL	221	025S0050EG	225	0415006PL	226
454008	14	0100037EG	221	0260037PL	230	0415008PL	226
454009	14	0100037PL	221	0260050PL	230	0415010PL	226
454010	14	0100050EG	221	0260062PL	230	0415012PL	226
454011	14	0100050PL	221	0260075PL	230	0422515EG	226
454012	14	0100062EG	221	0260087PL	230	0422520EG	226
454013	14	0100062PL	221	0300037PL	230	0423710EG	226
454014	14	0100075EG	221	0300050PL	230	0423715EG	226
454015	14	0100075PL	221	0300062PL	230	0423720EG	226
454016	14	0100087EG	221	0300075PL	230	0423725EG	226
454017	14	0100087PL	221	0300087PL	230	0423730EG	226
005275150PL	220	010H0025EG	221	0310037PL	231	0423740EG	226
005325275PL	220	010H0025PL	221	0310050PL	231	0425015EG	226
005550150PL	220	010H0037EG	221	0310062PL	231	0425020EG	226
0070050EG	45	010H0037PL	221	0310075PL	231	0425025EG	226
0070075EG	45	010H0050EG	221	0310087PL	231	0425030EG	226
0070100EG	45	010H0050PL	221	0310100PL	231	0425040EG	226
0070125EG	45	010H0062EG	221	0310125PL	231	0431402EG	227
0070150EG	45	010H0062PL	221	0310150PL	231	0431602EG	227
0070200EG	45	010H0075EG	221	0310175PL	231	0470025PL	234
0080025CP	48	010H0075PL	221	0310200PL	231	0470037PL	234
0080025EG	46	010H0087EG	221	034SL0600EG	110	0470050PL	234
0080037CP	48	010H0087PL	221	034SL0800EG	110	0470062PL	234
0080037EG	46	0110025EG	222	034SL1000EG	110	0470075PL	234
0080050CP	48	0110025PL	222	034SL1200EG	110	0470087PL	234
0080050EG	46	0110037EG	222	034SL1400EG	110	0502506EG	223
0080075CP	48	0110037PL	222	0350037PL	232	0502506PL	223
0080075EG	46	0110050EG	222	0350050PL	232	0502510EG	223
0080100CP	48	0110050PL	222	0350062PL	232	0502510PL	223
0080100EG	46	0110062EG	222	0350075PL	232	0502512EG	223
0080125CP	48	0110062PL	222	0350087PL	232	0502512PL	223
0080125EG	46	0110075EG	222	035RS0600EG	110	0503706EG	223

INDEX

Part No.	Page	Part No.	Page	Part No.	Page	Part No.	Page
0503706PL	223	085501000PL	235	102A0050VC	25	1080150EG	86
0503710EG	223	1000050EG	20	102A0075VC	25	1080200EG	86
0503710PL	223	1000050FL	23	102A0100VC	25	1090075EG	87
0503712EG	223	1000075EG	20	102A0125VC	25	1090100EG	87
0503712PL	223	1000075FL	23	102A0150VC	25	1090125EG	87
0505006EG	223	1000100EG	20	102A0200VC	25	1090150EG	87
0505006PL	223	1000100FL	23	102A0250VC	25	1090200EG	87
0505010EG	223	1000125EG	20	102A0300VC	25	1110075PL	15
0505010PL	223	1000125FL	23	102A0350VC	25	1110100PL	15
0505012EG	223	1000150EG	20	102A0400VC	25	1110125PL	15
0505012PL	223	1000150FL	23	102A0500VC	25	1110150PL	15
0506206EG	223	1000200EG	20	102A0600VC	25	1110200PL	15
0506206PL	223	1000200FL	23	1030150EG	26	1110250PL	15
0506210EG	223	1000250EG	20	1030200EG	26	1110300PL	15
0506210PL	223	1000250FL	23	1030250EG	26	1110350PL	15
0506212EG	223	1000300EG	20	1030300EG	26	1110400PL	15
0506212PL	223	1000300FL	23	1030350EG	26	1110500PL	15
0507506EG	223	1000350EG	20	1030400EG	26	1110600PL	15
0507506PL	223	1000350FL	23	1030500EG	26	1150250EG	21
0507510EG	223	1000400EG	20	1030600EG	26	1150300EG	21
0507510PL	223	1000400FL	23	1040100EG	27	1150350EG	21
0507512EG	223	1000500EG	20	1040100EG	27	1150400EG	21
0507512PL	223	1000600EG	20	1040100EG	27	1150500EG	21
0508706EG	223	1000800EG	20	1040100EG	27	1150600EG	21
0508706PL	223	100A0037EG	227	1040100EG	27	1150800EG	21
0508710EG	223	100A0050EG	227	1040100EG	27	1210150PL	157
0508710PL	223	1010050CP	22	1040200EG	27	1210200PL	157
0508712EG	223	1010075CP	22	1040200EG	27	1210250PL	157
0508712PL	223	1010100CP	22	1040200EG	27	1210300PL	157
0513702PL	224	1010125CP	22	1040200EG	27	1210350PL	157
0513703PL	224	1010150CP	22	1050050S4	210	1210400PL	157
0513704PL	224	1010200CP	22	1050075S4	210	1210500PL	157
0513705PL	224	1010250CP	22	1050100S4	210	1210600PL	157
0513706PL	224	1010300CP	22	1050125S4	210	1210800PL	157
0515004PL	224	1010350CP	22	1050150S4	210	1211000PL	157
0515005PL	224	1010400CP	22	1050200S4	210	1250150EG	156
0515006PL	224	1010500CP	22	1050250S4	210	1250200EG	156
0515010PL	224	1010600CP	22	1050300S4	210	1250250EG	156
0515012PL	224	1020050VC	24	1050350S4	210	1250300EG	156
080750450L	236	1020075VC	24	1050400S4	210	1250350EG	156
085370400PL	235	1020100VC	24	1050500S4	210	1250400EG	156
085370500PL	235	1020125VC	24	1050600S4	210	1250450EG	156
085370600PL	235	1020150VC	24	1050800S4	210	1250500EG	156
085370700PL	235	1020200VC	24	1070075EG	86	1250600EG	156
085370800PL	235	1020250VC	24	1070100EG	86	1250700EG	156
085370900PL	235	1020300VC	24	1070125EG	86	1250701EG	156
085371000PL	235	1020350VC	24	1070150EG	86	1250800EG	156
085500600PL	235	1020400VC	24	1070200EG	86	1250801EG	156
085500700PL	235	1020500VC	24	1080075EG	86	1250900EG	156
085500800PL	235	1020600VC	24	1080100EG	86	1251000EG	156
085500900PL	235	1020800VC	24	1080125EG	86	1251100EG	156



INDEX

Part No.	Page	Part No.	Page	Part No.	Page	Part No.	Page
1251200EG	156	150M0250EG	53	20MCP	54	300C3708EG	109
1251400EG	156	150M0250PL	53	20MCP24	56	300C3710EG	109
1251500EG	156	150M0250S4	213	20MCP58	56	300C3712EG	109
1251600EG	156	150M0300EG	53	20MCP912	56	300C3714EG	109
1251800EG	156	150M0300PL	53	24M	54	300C3716EG	109
1251900EG	156	150M0300S4	213	24M24	55	300C3718EG	109
1252000EG	156	150M0400EG	53	24M58	55	300C5008EG	109
1252200EG	156	150M0400PL	53	24M912	55	300C5010EG	109
1252400EG	156	150M0400S4	213	24MCP	54	300C5012EG	109
1252800EG	156	150M0500EG	53	24MCP24	56	300C5014EG	109
1351204EG	49	150M0500PL	53	24MCP58	56	300C5016EG	109
1351206EG	49	150M0500S4	213	24MCP912	56	300C6206EG	109
1351208EG	49	150M0600EG	53	2550037EG	94	300C6208EG	109
1351210EG	49	150M0600PL	53	2550037PL	94	300C6210EG	109
1351212EG	49	150M0600S4	213	2550050EG	94	300C6212EG	109
1352004EG	49	150M0800EG	53	2550050PL	94	300C6214EG	109
1352006EG	49	150M0800PL	53	2550062EG	94	300C7506EG	109
1352008EG	49	150M0800S4	213	2550062PL	94	300C7508EG	109
1352010EG	49	150M1000EG	53	255C3706EG	111	300C7510EG	109
1352012EG	49	150M1000PL	53	255C3708EG	111	300C7514EG	109
1353008EG	49	150M1000S4	213	255C3710EG	111	300C8706EG	109
1353010EG	49	150M1200EG	53	255C3714EG	111	300C8708EG	109
1353012EG	49	150M1200PL	53	255C5006EG	111	300C8710EG	109
1354008EG	49	150M1200S4	213	255C5008EG	111	300C8714EG	109
1354010EG	49	150M1400EG	53	255C6210EG	111	304B2	220
1354012EG	49	150M1400PL	53	255C6214EG	111	3050037S6	212
1390150EG	49	150M1400S4	213	255L0037EG	95	3050050S6	212
1390200EG	49	150M1600EG	53	255L0037PL	95	3100037EG	93
1390250EG	49	150M1600PL	53	255L0050EG	95	3100037PL	93
1390300EG	49	150M1600S4	213	255L0050PL	95	3100050EG	93
1390400EG	49	150M1800EG	53	255L0062EG	95	3100050PL	93
1450037EG	227	150M1800PL	53	255L0062PL	95	3150037EG	106
1450050EG	227	150M1800S4	213	2800037EG	91	3150037PL	106
150M0050EG	53	16M	54	2800037PL	91	3190100PL	127
150M0050PL	53	16M24	55	2800050EG	91	3190200PL	127
150M0050S4	213	16M58	55	2800050PL	91	320L0037PL	128
150M0075EG	53	16M912	55	2800062EG	91	320L0050PL	128
150M0075PL	53	16MCP	54	2800062PL	91	320L0062PL	128
150M0075S4	213	16MCP24	56	2800075EG	91	320L0075PL	128
150M0100EG	53	16MCP58	56	2800075PL	91	320L0087PL	128
150M0100PL	53	16MCP912	56	3000037EG*	92	320L0100PL	128
150M0100S4	213	2000037EG	97	3000037PL*	92	320L0125PL	128
150M0125EG	53	2000037PL	97	3000050EG*	92	320L0150PL	128
150M0125PL	53	2000050EG	97	3000050PL*	92	320L0175PL	128
150M0125S4	213	2000050PL	97	3000062EG	92	320L0200PL	128
150M0150EG	53	200RS375	98	3000062PL	92	320L0225PL	128
150M0150PL	53	200RS500	98	3000075EG	92	320L0250PL	128
150M0150S4	213	20M	54	3000075PL	92	320W0037PL	128
150M0200EG	53	20M24	55	3000087EG	92	320W0050PL	128
150M0200PL	53	20M58	55	3000087PL	92	320W0062PL	128
150M0200S4	213	20M912	55	300C3706EG	109	320W0075PL	128

INDEX

Part No.	Page	Part No.	Page	Part No.	Page	Part No.	Page
320W0087PL	128	3510200PL	130	365M0050CP	117	4020125CP	7
320W0100PL	128	3510300PL	130	365M0050EG	117	4020150CP	7
320W0112PL	128	3520100PL	131	365M0050PL	117	4020200CP	7
320W0150PL	128	3520200PL	131	370A0037PL	120	4020250CP	7
320W0175PL	128	3520300PL	131	370A0050PL	120	4020300CP	7
320W0200PL	128	3530100PL	132	370A0062PL	120	4020350CP	7
320W0225PL	128	3530200PL	132	370A0075PL	120	4020400CP	7
320W0250PL	128	3530300PL	132	370A0087PL	120	4020500CP	7
3250037EG	123	3530400PL	132	4010050EG	4	4020600CP	7
3250037PL	123	3530500PL	132	4010050RO	9	4020800CP	7
3250050EG	123	3530600PL	132	4010075EG	4	4030150EG	10
3250050PL	123	3550000EG	118	4010075RO	9	4030200EG	10
3250062EG	123	3550000PL	118	4010100EG	4	4030250EG	10
3250062PL	123	355N0025EG	119	4010100RO	9	4030300EG	10
3250075EG	123	355N0025PL	119	4010125EG	4	4030350EG	10
3250075PL	123	355N0037EG	119	4010125RO	9	4030400EG	10
3250087EG	123	355N0037PL	119	4010150EG	4	4030450EG	10
3250087PL	123	355N0050EG	119	4010150RO	9	4030500EG	10
3250100EG	123	355N0050PL	119	4010200EG	4	4030600EG	10
3250100PL	123	355N0062EG	119	4010200RO	9	4030700EG	10
3260037EG	124	355N0062PL	119	4010250EG	4	4030800EG	10
3260037PL	124	355N0075EG	119	4010250RO	9	4030900EG	10
3270037EG	125	355N0075PL	119	4010300EG	4	4031000EG	10
3270037PL	125	355N0087EG	119	4010300RO	9	4031100EG	10
3270050EG	125	355N0087PL	119	4010350EG	4	4031200EG	10
3270050PL	125	3560100PL	111	4010350RO	9	4031400EG	10
3280037EG	126	3560200PL	111	4010400EG	4	4031500EG	10
3280037PL	126	3560300PL	111	4010400RO	9	4031600EG	10
3280050PL	126	3560400PL	111	4010500EG	4	4031700EG	10
32M	54	3560500PL	111	4010500RO	9	4031800EG	10
32M24	55	3600000PL	112	4010600EG	4	4031900EG	10
32M58	55	361024050PL	113	4010600RO	9	4032000EG	10
32M912	55	361025062PL	113	4010800EG	4	4032100EG	10
32MCP	54	361026075PL	113	4010800RO	9	4032200EG	10
32MCP24	56	361027087PL	113	4011000EG	4	4050300PL	11
32MCP58	56	361028087PL	113	4011000RO	9	4050400PL	11
32MCP912	56	361054050PL	113	4011200EG	4	4050600PL	11
340A2503PL	127	361055062PL	113	4011200RO	9	4050800PL	11
340B2503PL	127	361056075PL	113	4011400EG	4	4051000PL	11
340C3703PL	127	361057087PL	113	4011400RO	9	4051200PL	11
340D3704PL	127	361058087PL	113	4011600EG	4	4051400PL	11
340E5004PL	127	3630037PL	114	4011600RO	9	4051600PL	11
345R0037EG	229	3630050PL	114	4011800EG	4	4051800PL	11
345R0050EG	229	3630062PL	114	4011800RO	9	4052000PL	11
345R0062EG	229	3630075PL	114	4012000EG	4	4052400PL	11
3480100PL	129	3650037CP	117	4012000RO	9	4060050S4	211
3480200PL	129	3650037EG	117	4012400EG	4	4060075S4	211
3480300PL	129	3650037PL	117	4012400RO	9	4060100S4	211
3500037PL	130	365M0037CP	117	4020050CP	7	4060125S4	211
3500050PL	130	365M0037EG	117	4020075CP	7	4060150S4	211
3510100PL	130	365M0037PL	117	4020100CP	7	4060200S4	211



INDEX

Part No.	Page	Part No.	Page	Part No.	Page	Part No.	Page
4060250S4	211	4200075EP	8	4520200PL	38	4560300CP	18
4060300S4	211	4200100EP	8	4520250PL	38	4700050PL	47
4060350S4	211	4200125EP	8	4520300PL	38	4700075PL	47
4060400S4	211	4200150EP	8	4520400PL	38	4700100PL	47
4060500S4	211	4200200EP	8	4520500PL	38	4700125PL	47
4060600S4	211	4200250EP	8	4520600PL	38	4700150PL	47
4060800S4	211	4200300EP	8	4520800PL	38	4700200PL	47
4061000S4	211	4200400EP	8	4521000PL	38	4700250PL	47
4061200S4	211	4200500EP	8	4521200PL	38	4700300PL	47
4061400S4	211	4200600EP	8	4521400PL	38	4700400PL	47
4061600S4	211	4200800EP	8	4521600PL	38	4H24	237
4061800S4	211	4270200EG	5	4521800PL	38	4H58	237
4062000S4	211	4270400EG	5	4522000PL	38	4H912	237
4062400S4	211	4500050PL	36	4522400PL	38	4T124	133
4100050EG	6	4500075PL	36	4530600PL	39	4T158	133
4100075EG	6	4500100PL	36	4530800PL	39	4T1912	133
4100100EG	6	4500125PL	36	4531000PL	39	5100050EG	32
4100125EG	6	4500150PL	36	4531200PL	39	5100050RO	33
4100150EG	6	4500200PL	36	4531400PL	39	5100075EG	32
4100200EG	6	4500250PL	36	4531600PL	39	5100075RO	33
4100250EG	6	4500300PL	36	4531800PL	39	5100100EG	32
4100300EG	6	4500350PL	36	4532000PL	39	5100100RO	33
4100350EG	6	4500400PL	36	4532400PL	39	5100125EG	32
4100400EG	6	4500500PL	36	4550037EG	17	5100125RO	33
4100500EG	6	4500600PL	36	4550037PL	17	5100150EG	32
4100600EG	6	4500800PL	36	4550050EG	17	5100150RO	33
4100800EG	6	4501000PL	36	4550050PL	17	5100200EG	32
4180050EG	28	4501200PL	36	4550075EG	17	5100200RO	33
4180050FL	29	4501400PL	36	4550075PL	17	5100250EG	32
4180075EG	28	4501600PL	36	4550100EG	17	5100250RO	33
4180075FL	29	4501800PL	36	4550100PL	17	5100300EG	32
4180100EG	28	4502000PL	36	4550125EG	17	5100300RO	33
4180100FL	29	4502400PL	36	4550125PL	17	5100350EG	32
4180125EG	28	4503000PL	37	4550150EG	17	5100350RO	33
4180125FL	29	4510300EG	37	4550150PL	17	5100400EG	32
4180150EG	28	4510400EG	37	4550200EG	17	5100400RO	33
4180150FL	29	4510500EG	37	4550200PL	17	5100500EG	32
4180200EG	28	4510600EG	37	4550250EG	17	5100500RO	33
4180200FL	29	4510800EG	37	4550250PL	17	5100600EG	32
4180250EG	28	4511000EG	37	4550300EG	17	5100600RO	33
4180250FL	29	4511200EG	37	4550300PL	17	5100800EG	32
4180300EG	28	4511400EG	37	4550400EG	17	5100800RO	33
4180300FL	29	4511600EG	37	4550400PL	17	5101000EG	32
4180350EG	28	4511800EG	37	4560037CP	18	5101000RO	33
4180350FL	29	4512000EG	37	4560050CP	18	5101200EG	32
4180400EG	28	4512400EG	37	4560075CP	18	5101200RO	33
4180400FL	29	4520050PL	38	4560100CP	18	5101400EG	32
4180500EG	28	4520075PL	38	4560125CP	18	5101600EG	32
4180600EG	28	4520100PL	38	4560150CP	18	5101800EG	32
4180800EG	28	4520125PL	38	4560200CP	18	5102000EG	32
4200050EP	8	4520150PL	38	4560250CP	18	5102400EG	32

INDEX

Part No.	Page	Part No.	Page	Part No.	Page	Part No.	Page
5110050CP	34	6051600PL	136	6200400PL	141	6340200PL	164
5110075CP	34	6051800PL	136	6200500PL	141	6340250PL	164
5110100CP	34	6052000PL	136	6200600PL	141	6340300PL	164
5110125CP	34	6052400PL	136	6200800PL	141	6340350PL	164
5110150CP	34	6053000PL	136	6201000PL	141	6340500PL	164
5110200CP	34	6100300PL	137	6201200PL	141	6340800PL	164
5110250CP	34	6100350PL	137	6201400PL	141	6341000PL	164
5110300CP	34	6100400PL	137	6201600PL	141	6341200PL	164
5110400CP	34	6100500PL	137	6201800PL	141	6341400PL	164
5110500CP	34	6100600PL	137	6202000PL	141	6341600PL	164
5110600CP	34	6100800PL	137	6202400PL	141	6341800PL	164
5160075PL	42	6101000PL	137	6203000PL	141	6342000PL	164
5160125PL	42	6101200PL	137	6300150PL	160	6342400PL	164
5160137PL	42	6101400PL	137	6300350PL	160	6350400PL	165
5160150PL	42	6101600PL	137	6300500PL	160	6350500PL	165
5170300PL	42	6101800PL	137	6300600PL	160	6350800PL	165
5170400PL	42	6102000PL	137	6300800PL	160	6351000PL	165
5170600PL	42	6102400PL	137	6310150PL	161	6351200PL	165
5170800PL	42	6150250PL	138	6310350PL	161	6351600PL	165
5171000PL	42	6150300PL	138	6310500PL	161	6351800PL	165
5171200PL	42	6150350PL	138	6310800PL	161	6352000PL	165
5171400PL	42	6150400PL	138	6311000PL	161	6352400PL	165
5171600PL	42	6150500PL	138	6311200PL	161	6500100PT	147
5171800PL	42	6150600PL	138	6311400PL	161	6500200PT	147
5172000PL	42	6150800PL	138	6311600PL	161	6500300PT	147
5172400PL	42	6151000PL	138	6311800PL	161	6500400PT	147
5200050EP	35	6151200PL	138	6312000PL	161	6500500PT	147
5200075EP	35	6151400PL	138	6312400PL	161	6500600PT	147
5200100EP	35	6151600PL	138	6320150PL	162	6500700PT	147
5200125EP	35	6151800PL	138	6320350PL	162	6500800PT	147
5200150EP	35	6152000PL	138	6320500PL	162	6500900PT	147
5200200EP	35	6152400PL	138	6320800PL	162	6501000PT	147
5200250EP	35	6170350PL	139	6321000PL	162	6501100PT	147
5200300EP	35	6170600PL	139	6321200PL	162	6501200PT	147
5200400EP	35	6171000PL	139	6321400PL	162	6501300PT	147
5200500EP	35	6171400PL	139	6321600PL	162	6501400PT	147
5200600EP	35	6172000PL	139	6321800PL	162	6510100PT	149
5200800EP	35	6172400PL	139	6322000PL	162	6510200PT	149
5470037PL	99	6173000PL	139	6322400PL	162	6510300PT	149
5480050PL	99	6174200PL	139	6330150PL	163	6510400PT	149
6010250PL	137	6190350PL	140	6330200PL	163	6510500PT	149
6050250PL	136	6190600PL	140	6330250PL	163	6510600PT	149
6050300PL	136	6191000PL	140	6330300PL	163	6510700PT	149
6050350PL	136	6191400PL	140	6330350PL	163	6510800PT	149
6050400PL	136	6192000PL	140	6330500PL	163	6510900PT	149
6050500PL	136	6192400PL	140	6330800PL	163	6511000PT	149
6050600PL	136	6193000PL	140	6331000PL	163	6511100PT	149
6050800PL	136	6194200PL	140	6331600PL	163	6511200PT	149
6051000PL	136	6200250PL	141	6331800PL	163	6MCP24	56
6051200PL	136	6200300PL	141	6332000PL	163	6MCP58	56
6051400PL	136	6200350PL	141	6332400PL	163	6MCP912	56



INDEX

Part No.	Page	Part No.	Page	Part No.	Page	Part No.	Page
6TI24	133	7230350PL	152	812M58	55	BC17D000EG	186
6TI58	133	7230400PL	152	812M912	55	BC260025EG	96
6TI912	133	7230500PL	152	812MCP	54	BH0050CP	15
7000050PL	40	7230600PL	152	812MCP24	56	BH0075CP	15
7000075PL	40	7230800PL	152	812MCP58	56	BH0100CP	15
7000100PL	40	7231000PL	152	812MCP912	56	BR220600EG	187
7000125PL	40	7231200PL	152	A121000PG	173	BR221200EG	187
7000150PL	40	7231400PL	152	A122000GN	173	BR221800EG	187
7000200PL	40	7231600PL	152	A122000PG	173	BR222400EG	187
7000250PL	40	7231800PL	152	A122000PL	173	BR223000EG	187
7000300PL	40	7232000PL	152	A12A2000GN	173	BR223600EG	187
7000400PL	40	7232400PL	152	A12A2000PG	173	C121000AL	175
7000500PL	40	7232600PL	152	A12AH100PG	173	C121000PG	175
7000600PL	40	7233000PL	152	A12AH200GN	173	C122000AL	175
7000800PL	40	7233200PL	152	A12AH200PG	173	C122000GN	175
7050050PL	41	7233600PL	152	A12H1000CG	173	C12H1000CG	175
7050075PL	41	7240250PL	153	A12H1000GN	173	C12H1000GN	175
7050100PL	41	7240300PL	153	A12H1000PG	173	C12H1000PG	175
7050125PL	41	7240350PL	153	A12H1000S4	173	C12H2000GN	175
7050150PL	41	7240400PL	153	A12H2000CG	173	C12H2000PG	175
7050200PL	41	7240500PL	153	A12H2000GN	173	C141000PG	176
7050250PL	41	7240600PL	153	A12H2000PG	173	C141000S4	176
7050300PL	41	7240800PL	153	A14H1000GN	174	C142000S4	176
7050350PL	41	7241000PL	153	A14H1000PG	174	C14H1000CG	176
7050400PL	41	7241200PL	153	A14H2000GN	174	C14H1000GN	176
7050500PL	41	7241400PL	153	A14H2000PG	174	C14H1000PG	176
7050600PL	41	7241600PL	153	AF144TI	133	C14H1000S4	176
7050800PL	41	7241800PL	153	AF146TI	133	C14H2000CG	176
7210250PL	150	7242000PL	153	B122000GN	174	C14H2000GN	176
7210300PL	150	7242400PL	153	B122000PG	174	C14H2000PG	176
7210400PL	150	7242600PL	153	B12H1000PG	174	C14S2000GN	176
7210500PL	150	7243000PL	153	B12H2000GN	174	CD0B	57
7210600PL	150	7243200PL	153	B12H2000PG	174	CD0B37	57
7210800PL	150	7243600PL	153	BC090900EG	105	CD0B37CP	58
7211000PL	150	800037050EP	59	BC091200EG	105	CD0BCP	58
7211200PL	150	800050075EP	59	BC091500EG	105	CD1B	57
7211400PL	150	800075100EP	59	BC100000EG	104	CD1B37	57
7211600PL	150	800100125EP	59	BC101500EG	105	CD1B37CP	58
7211800PL	150	801000200EP	59	BC130025EG	102	CD1BCP	58
7212000PL	150	801037050EP	59	BC130031EG	102	CD2.53B37CP	58
7212400PL	150	801050075EP	59	BC130037EG	102	CD2.5BCP	58
7212600PL	150	801075100EP	59	BC130050EG	102	CD2B	57
7213000PL	150	801100125EP	59	BC130062EG	102	CD2B37	57
7213200PL	150	801125150EP	59	BC130075EG	102	CD2B37CP	58
7213600PL	150	801150000EP	59	BC140025EG	103	CD2BCP	58
7220400PL	151	801200000EP	59	BC140037EG	103	CD3B	57
7220600PL	151	802037050EP	60	BC140050EG	103	CD3B37	57
7220800PL	151	802050075EP	60	BC140062EG	103	CD3B37CP	58
7221000PL	151	802075100EP	60	BC16A000EG	186	CD3BCP	58
7230250PL	152	812M	54	BC16C000EG	186	CD4B	57
7230300PL	152	812M24	55	BC17A000EG	186	CD4B37	57

INDEX

Part No.	Page	Part No.	Page	Part No.	Page	Part No.	Page
CD5B	57	EPS0050EG	60	HSCR3712PL	235	NUT0031EG	180
CD5B37	57	EPS0075EG	60	HSCR3715EG	235	NUT0037EG	180
CD5B37CP	58	EPS0100EG	60	HSCR3715PL	235	NUT0050EG	180
CD5BCP	58	EPS0125EG	60	HSCR3720EG	235	NUT0062EG	180
CD6B	57	EPS0150EG	60	HSCR3720PL	235	NUT0075EG	180
CD7B	57	EPS0200EG	60	HSCR5007EG	235	NUT0087EG	180
CD8B	57	ESGP	238	HSCR5010EG	235	NUTC0050EG	180
CD9B	57	ET0050HD	107	HSCR5012EG	235	NUTC0062EG	180
CL100000CG	187	ET0075HD	107	HSCR5015EG	235	NUTC0075EG	180
CL100000EG	187	ET0100HD	107	HSCR5020EG	235	NUTC0087EG	180
CL100000GN	187	ET0125HD	107	L100000EG	193	OD0025EG	75
CL100000PS	187	ET0150HD	107	L110000EG	193	OD0025S4	214
CONA122000PG	177	ET0200HD	107	L120300EG	194	OD0037EG	75
CONB122000PG	177	ET0250HD	107	L120350EG	194	OD0037S4	214
CONC122000PG	177	ET0300HD	107	L120400EG	194	OD0050EG	75
COPC0025CP	78	F090000EG	188	L150000EG	194	OD0050S4	214
COPC0037CP	78	F100000EG	189	L160000EG	195	OD0062EG	75
COPC0050CP	78	F110000EG	189	L170000EG	195	OD0062S4	214
COPC0075CP	78	F120000EG	189	L180000EG	195	OD0075EG	75
COPC0100CP	78	F120062EG	189	L190000EG	196	OD0075S4	214
COPC0125CP	78	F120075EG	189	L200000EG	196	OD0087EG	75
COPC0150CP	78	F130000EG	189	L220000EG	196	OD0087S4	214
COPC0200CP	78	F140000EG	189	L23U0000EG	197	OD0100EG	75
COPC0250CP	78	F150000EG	189	L24L0000EG	197	OD0100S4	214
COPC0300CP	78	F160000EG	189	L24R0000EG	197	OD0112EG	75
COPC0350CP	78	F170000EG	189	L25L0000EG	198	OD0112S4	214
COPC0400CP	78	F180000EG	189	L25R0000EG	198	OD0125EG	75
COPC0500CP	78	F200000EG	190	L26L0000EG	198	OD0125S4	214
COPC0600CP	78	F220000EG	190	L26R0000EG	198	OD0137EG	75
D122000PG	176	F230000EG	191	L270000EG	199	OD0137S4	214
D12H1000GN	176	F250000EG	191	L441200EG	199	OD0150EG	75
D12H1000PG	176	F360000EG	192	L441600EG	199	OD0150S4	214
D12H2000GN	176	F370000EG	192	L441800EG	199	OD0162EG	75
D12H2000PG	176	HMZE200	228	L460300EG	200	OD0162S4	214
D12S2000GN	176	HMZE215	228	L460450EG	200	OD0175EG	75
E122000GN	177	HMZE220	228	L460600EG	200	OD0175S4	214
E12H1000GN	177	HMZE230	228	L470300EG	200	OD0187EG	75
E12H1000PG	177	HMZE380	228	L470450EG	200	OD0187S4	214
E12H2000GN	177	HMZG471	228	L470600EG	200	OD0200EG	75
E12H2000PG	177	HMZG550	228	L470825EG	200	OD0200S4	214
EMTC0050EG	78	HMZG660	228	LHSR6	20	OD0212EG	75
EMTC0075EG	78	HMZG730	228	MSP20	238	OD0212S4	214
EMTC0100EG	78	HMZG735	228	MSR24	71	OD0225EG	75
EMTC0125EG	78	HMZH455	228	MSR58	71	OD0225S4	214
EMTC0150EG	78	HMZH475	228	MSR912	71	OD0237EG	75
EMTC0200EG	78	HMZH476	228	MSS24	72	OD0237S4	214
ENDCA120EG	188	HMZH665	228	MSS58	72	OD0250EG	75
ENDCA140EG	188	HSCR3707EG	235	MSS912	72	OD0250S4	214
ENDCB120EG	188	HSCR3710EG	235	NUT0008EG	180	OD0262EG	75
ENDCC140EG	188	HSCR3710PL	235	NUT0010EG	180	OD0262S4	214
ENDCE120EG	188	HSCR3712EG	235	NUT0025EG	180	OD0275EG	75



INDEX

Part No.	Page	Part No.	Page	Part No.	Page	Part No.	Page
OD0275S4	214	OD0600EG	75	PAR0100HD	107	RIGD0125S4	215
OD0287EG	75	OD0600S4	214	PAR0125HD	107	RIGD0150EG	74
OD0287S4	214	OD0612EG	75	PAR0150HD	107	RIGD0150S4	215
OD0300EG	75	OD0612S4	214	PAR0200HD	107	RIGD0200EG	74
OD0300S4	214	OD0625EG	75	PAR0250HD	107	RIGD0200S4	215
OD0312EG	75	OD0625S4	214	PAR0300HD	107	RIGD0250EG	74
OD0312S4	214	OD0637EG	75	PAR0350HD	107	RIGD0250S4	215
OD0325EG	75	OD0637S4	214	PAR0400HD	107	RIGD0300EG	74
OD0325S4	214	OD0650EG	75	PCC0025EG	76	RIGD0300S4	215
OD0337EG	75	OD0650S4	214	PCC0037EG	76	RIGD0350EG	74
OD0337S4	214	OD0662EG	75	PCC0050EG	76	RIGD0350S4	215
OD0350EG	75	OD0662S4	214	PCC0075EG	76	RIGD0400EG	74
OD0350S4	214	OD0675EG	75	PCC0100EG	76	RIGD0400S4	215
OD0362EG	75	OD0675S4	214	PCC0125EG	76	RIGD0500EG	74
OD0362S4	214	OD0687EG	75	PCC0150EG	76	RIGD0500S4	215
OD0375EG	75	OD0687S4	214	PCC0200EG	76	RIGD0600EG	74
OD0375S4	214	OD0700EG	75	PCC0250EG	76	RIGD0600S4	215
OD0387EG	75	OD0700S4	214	PCC0300EG	76	RIGD0800EG	74
OD0387S4	214	OD0712EG	75	PCC0350EG	76	RIGD0800S4	215
OD0400EG	75	OD0712S4	214	PCC0400EG	76	ROL1000EG	203
OD0400S4	214	OD0725EG	75	PCC0500EG	76	ROL1100EG	203
OD0412EG	75	OD0725S4	214	PCC0600EG	76	ROL1200EG	142
OD0412S4	214	OD0737EG	75	PH4	100	ROL13034EG	142
OD0425EG	75	OD0737S4	214	PH6	100	ROL13046EG	142
OD0425S4	214	OD0750EG	75	PH6FP	100	ROL13068EG	142
OD0437EG	75	OD0750S4	214	PHSW4	101	ROL14000EG	144
OD0437S4	214	OD0762EG	75	PHSW6	101	ROL15000EG	145
OD0450EG	75	OD0762S4	214	PHSW6FP	101	RPS150T1	68
OD0450S4	214	OD0775EG	75	PPRPS25H4	66	RPS150T2	68
OD0462EG	75	OD0775S4	214	PPRPS25H6	66	RPS300T1	68
OD0462S4	214	OD0787EG	75	RA0037HD	108	RPS300T2	68
OD0475EG	75	OD0787S4	214	RA0050HD	108	RPS50AHSV	67
OD0475S4	214	OD0800EG	75	RA0075HD	108	RPS50H4EG	67
OD0487EG	75	OD0800S4	214	RA0100HD	108	RPS50H6EG	67
OD0487S4	214	OD0812EG	75	RA0125HD	108	RPS600T2	68
OD0500EG	75	OD0812S4	214	RA0150HD	108	RPCSCSEG	68
OD0500S4	214	OD0825EG	75	RA0200HD	108	SAA1400EG	240
OD0512EG	75	OD0825S4	214	RA0250HD	108	SAD1400EG	240
OD0512S4	214	OD0837EG	75	RA0300HD	108	SAE1200EG	241
OD0525EG	75	OD0837S4	214	RA0350HD	108	SCH12	80
OD0525S4	214	OD0850EG	75	RA0400HD	108	SCH12B	80
OD0537EG	75	OD0850S4	214	RAWL3758	229	SCH16	80
OD0537S4	214	OD0862EG	75	RIGD0037EG	74	SCH16B	80
OD0550EG	75	OD0862S4	214	RIGD0037S4	215	SCH20	80
OD0550S4	214	P090000EG	201	RIGD0050EG	74	SCH20B	80
OD0562EG	75	P100000EG	201	RIGD0050S4	215	SCH24B	80
OD0562S4	214	P110000EG	202	RIGD0075EG	74	SCH32B	80
OD0575EG	75	P130000EG	202	RIGD0075S4	215	SCH40B	80
OD0575S4	214	PAR0037HD	107	RIGD0100EG	74	SCH48B	80
OD0587EG	75	PAR0050HD	107	RIGD0100S4	215	SCH56B	80
OD0587S4	214	PAR0075HD	107	RIGD0125EG	74	SCH64B	80

INDEX

Part No.	Page	Part No.	Page	Part No.	Page	Part No.	Page
SCH6B	80	SLWPT	64	STR0062EG	45	TCC0150CP	77
SCH72B	80	SMS8	52	STR0062EG	82	TCC0162CP	77
SCH8	80	SO12A	87	STR0075EG	45	TCC0175CP	77
SCH8B	80	SO16A	87	STR0075EG	82	TCC0187CP	77
SGB16A	52	SO20A	87	STR0087EG	45	TCC0200CP	77
SGB24A	52	SO24A	87	STR0087EG	82	TCC0212CP	77
SK125I	81	SO32A	87	STR0100EG	45	TCC0250CP	77
SK165I	81	SPRA0008EG	181	STR0100EG	82	TCC0262CP	77
SK205I	81	SPRA0010EG	181	STR20050EG	47	TCC0300CP	77
SK245I	81	SPRA0025EG	181	STR20050EG	82	TCC0312CP	77
SK325I	81	SPRA0031EG	181	STR20075EG	47	TCC0331CP	77
SK405I	81	SPRA0037EG	181	STR20075EG	82	TCC0362CP	77
SK485I	81	SPRA0050EG	181	STR20100EG	47	TCC0412CP	77
SK565I	81	SPRA0062EG	181	STR20100EG	82	TCC0431CP	77
SK645I	81	SPRA0075EG	181	STR20125EG	47	TCC0512CP	77
SK85I	81	SPRA0087EG	181	STR20125EG	82	TCC0612CP	77
SL1214	64	SPRC0008EG	181	STR20150EG	47	TP2201000125PL	244
SL1518	64	SPRC0010EG	181	STR20150EG	82	TP2201000150PL	244
SLADCP	64	SPRC0025EG	181	STR20200EG	47	TP2201000200PL	244
SLADS	64	SPRC0031EG	181	STR20200EG	82	TP2201000250PL	244
SLD15L10	63	SPRC0037EG	181	STR20250EG	47	TP2201000300PL	244
SLD15L10S	63	SPRC0050EG	181	STR20250EG	82	TP2201000400PL	244
SLD15L2	63	SPRC0062EG	181	STR20300EG	47	TP2201000500PL	244
SLD15L2S	63	SPRC0075EG	181	STR20300EG	82	TP2201000600PL	244
SLD15L5	63	SPRC0087EG	181	STR20350EG	47	TP2201000800PL	244
SLD15L5S	63	SPRD0025EG	182	STR20350EG	82	TP2201250125PL	244
SLD2L1	62	SPRD0037EG	182	STR20400EG	47	TP2201250150PL	244
SLD2L10	62	SPRD0050EG	182	STR20400EG	82	TP2201250200PL	244
SLD2L1BP	62	SPRD0062EG	182	STR20500EG	47	TP2201250250PL	244
SLD2L2	62	SPRD0075EG	182	STR20500EG	82	TP2201250300PL	244
SLD2L2BP	62	SPRM2508EG	182	STR20600EG	47	TP2201250400PL	244
SLD2L3	62	SPRM2511EG	182	STR20600EG	82	TP2201250500PL	244
SLD2L3BP	62	SPRM2515EG	182	STS	179	TP2201250600PL	244
SLD2L5	62	SPRM3708EG	182	SWF0037EG	231	TP2201250800PL	244
SLD3L1	62	SPRM3711EG	182	SWF0050EG	231	TP225100PL	245
SLD3L10	62	SPRM3716EG	182	SWFF0037EG	232	TP225125PL	245
SLD3L2	62	SPRM3718EG	182	SWFF0050EG	232	TP225A000PL	245
SLD3L2BP	62	SPRM3721EG	182	SWM0037EG	233	TP225G100PL	245
SLD3L2SS	62	SPRM5011EG	182	SWM0050EG	233	TP225G125PL	245
SLD3L3	62	SPRM5013EG	182	SWMF0037EG	234	TP2301000100PL	246
SLD3L3BP	62	SQNT0025EG	183	SWMF0050EG	234	TP2301000125PL	246
SLD3L3SS	63	SQNT0037EG	183	TCC0025CP	77	TP2301000150PL	246
SLD3L5	62	SQNT0050EG	183	TCC0037CP	77	TP2301000200PL	246
SLEB250	64	SQNT0062EG	183	TCC0050CP	77	TP2301000250PL	246
SLEB375	64	STCB6	185	TCC0062CP	77	TP2301000300PL	246
SLEBWS	64	STR0025EG	45	TCC0075CP	77	TP2301000400PL	246
SLICK250	178	STR0025EG	82	TCC0087CP	77	TP2301000500PL	246
SLICK375	178	STR0037EG	45	TCC0100CP	77	TP2301000600PL	246
SLICK500	178	STR0037EG	82	TCC0112CP	77	TP2301000800PL	246
SLLC250	64	STR0050EG	45	TCC0125CP	77	TP2301250125PL	246
SLWC	64	STR0050EG	82	TCC0137CP	77	TP2301250150PL	246



INDEX

Part No.	Page	Part No.	Page
TP2301250200PL	246	UNIV0125EG	83
TP2301250250PL	246	UNIV0150EG	83
TP2301250300PL	246	UNIV0200EG	83
TP2301250400PL	246	VAFT	64, 134
TP2301250500PL	246	VF144TI	134
TP2301250600PL	246	VF146TI	134
TP2301250800PL	246	VS0050EG	183
TP230G1000600PL	246	VS200000	83
TP230G1000800PL	246	VTR#11000	27
TP230G1250600PL	246	VTR#21000	27
TP230G1250800PL	246	W10L0000EG	205
TP235100PL	247	W10R0000EG	205
TP235125PL	247	W120000EG	205
TP2401000100EG	247	W130000EG	206
TP2401000100PL	247	W170000EG	206
TP2401000125EG	247	W180000EG	207
TP2401000125PL	247	W190000EG	207
TP2800100PL	248	W200000EG	208
TP280P0100PL	248	W230000EG	208
TPC112	51	WH02050CP	50
TPC238	51	WH02075CP	50
TSGB16	52	WH04050CP	50
TSGB16112	51	WH04050PL	50
TSGB24	52	WH04050VC	50
TSGB24112	51	WH04075CP	50
TSM0037	79	WH04075PL	50
TSM0050	79	WH04075VC	50
TSM0062	79	WH06050CP	50
TSM0075	79	WH06050PL	50
TSM0087	79	WH06050VC	50
TSM0112	79	WH06075CP	50
TSM0137	79	WH06075PL	50
TSM0162	79	WH06075VC	50
TSMI0037	79	WH06100CP	50
TSMI0050	79	WH06100PL	50
TSMI0062	79	WH06100VC	50
TSMI0075	79	WH06125PL	50
TSMI0087	79	WH06125VC	50
TSMI0112	79	WH06150PL	50
TSMI0137	79	WH06150VC	50
TSMI0162	79	WH08075CP	50
TSNT0025EG	183	WH08075PL	50
TSNT0037EG	183	WH08075VC	50
TSNT0050EG	183	WH08200PL	50
U10A0000EG	204	WH08200VC	50
U24A0000EG	204	WH10200PL	50
U24C0000EG	204		
U24D0000EG	204		
UNIV0050EG	83		
UNIV0075EG	83		
UNIV0100EG	83		

ERICO® Online

Visit the ERICO website at www.erico.com for new product information, up-to-date product specifications and applications, a list of upcoming events and industry tradeshow participation and more.

An electronic library provides pertinent product literature in an easy-to-download PDF format. This is a great way to stay informed on all the current publications. New product brochures and datasheets are posted as soon as they are produced.

In the News & Events section, customers can find new product updates, press releases and lists of seminars.

Locations and contact information is listed for ERICO offices around the world.

www.erico.com provides a convenient way to get the answers you need day or night. Visit ERICO online.

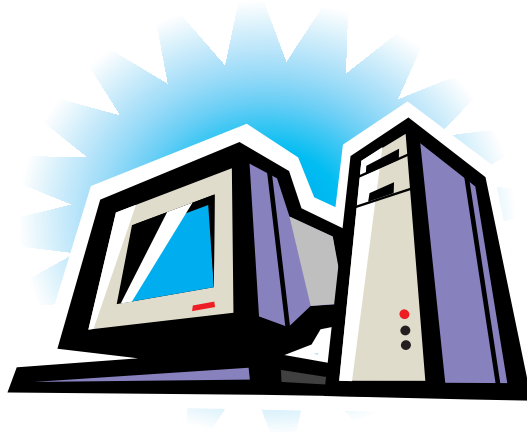

ERICO®



www.erico.com



AUSTRALIA

6 Chilvers Road
P.O. Box 148
Thornleigh (Sydney) NSW 2120
Australia
Phone 61-2-9479-8500
Fax 61-2-9484-9188



GERMANY

66851 Schwannemühle
Germany
Phone 49-6307-918-10
Fax 49-6307-918-150



POLAND

ul. Krzemieniecka 17
54-613 Wrocław
Poland
Phone 48-71-374-40-22
Fax 48-71-374-40-43



BELGIUM

Postbus 33
3110 Rotselaar
Belgium
Phone 32-14-69-96-88
Fax 32-14-69-96-90



HONG KONG

Unit 1, 2nd Floor, Block A
Po Yip Building
62-70 Texaco Road
Tsuen Wan, New Territories
Hong Kong
Phone 852-2764-8808
Fax 852-2764-4486



SINGAPORE

Jurong Industrial Estate
16 Wan Lee Road
Singapore 627 946
Phone 65-6-268-3433
Fax 65-6-268-1389



BRAZIL

R. Dom Pedro Henrique de Orleans
E Braganca, 276
Vila Jaguara
São Paulo CEP 05117-000
Brazil
Phone 55-11-3621-4111
Fax 55-11-3621-4066



HUNGARY

P.f. 184
1476 Budapest
Hungary
Phone 31-13-58-34-547
Fax 31-13-58-35-499



SPAIN

C/Provenza 288, Pral.
08008 Barcelona
Spain
Phone 34-93-467-7726
Fax 34-93-467-7725



CANADA

P.O. Box 170
Mississauga, Ontario
Canada L5M 2B8
Phone 1-800-677-9089
Fax 1-800-677-8131

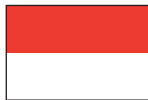

INDONESIA

Sudirman Square Tower B 19th Fl.
Jalan Jend. Sudirman Kav. 45-46
Jakarta 12930
Indonesia
Phone 62-21-575-0941
Fax 62-21-575-0942



SWEDEN

Box 211
201 22 Malmö
Sweden
Phone 46-40-611-13-60
Fax 46-40-611-94-15



CHILE

Alcantara 200, piso 6 Of. 17
Las Condes, Santiago
Chile
Phone 56-2-370-2908
Fax 56-2-370-2914



ITALY

A&B Business Center
Via Vallia 16, nr. 17
20141 Milano
Italy
Phone 39-02-8474-2250
Fax 39-02-8474-2251



SWITZERLAND

Postfach 54
3280 Murten
Switzerland
Phone 00-800-5000-1090
Fax 00-800-6000-1090

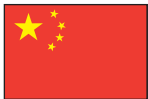

CHINA

Room 1204
Tomson Commercial Building
No. 710 Dongfang Road
Pudong, Shanghai
P.R. China 200122
Phone 86-21-5081-3900
Fax 86-21-5831-8177



MEXICO

Melchor Ocampo 193
Torre A piso 13
Col. Veronica Anzures
11300 Mexico D.F.
Mexico
Phone 52-55-5260-5991
Fax 52-55-5260-3310



THAILAND

163 Ocean Insurance Bldg.
16th Fl. Unit B
Surawongse Road
Bangrak Bangkok 10500
Thailand
Phone 66-2-634-1692
Fax 66-2-634-1694



DENMARK

Box 211
201 22 Malmö
Sweden
Phone 46-40-611-13-60
Fax 46-40-611-94-15



NETHERLANDS

Jules Verneweg 75
5015 BG Tilburg
Netherlands
Phone 31-13-58-35-400
Fax 31-13-58-35-499



UNITED KINGDOM

52 Milford Road
Reading, Berkshire RG1 8LJ
United Kingdom
Phone 44-118-958-8386
Fax 44-118-955-0925



FRANCE

Rue Benoit Fourneryon Z.I. Sud
Boîte Postale 31
42161 Andrezieux Cedex
France
Phone 33-4-77-36-56-56
Fax 33-4-77-55-37-89



NORWAY

Postboks 148
1366 Lysaker
Norway
Phone 47-67-53-12-00
Fax 47-67-12-42-68



UNITED STATES

34600 Solon Road
Solon, Ohio 44139
U.S.A.
Phone 1-440-248-0100
Fax 1-440-248-0723